



SAFETY & OPERATING INSTRUCTIONS



610



610M

CROWN PUNCH CAN OPENER, Models 610 & 610M

⚠ WARNING

READ AND UNDERSTAND THIS MANUAL AND ALL INSTRUCTIONS BEFORE OPERATING THIS OPENER.

Table of Contents

CHAPTER 1 - INTRODUCING THE EDLUND CROWN PUNCH CAN OPENER 1
 Conventions used in this manual 1
 Specifications for the Edlund CROWN PUNCH CAN OPENER, Models 610 & 610M 2

CHAPTER 2 - GENERAL SAFETY RULES 3
 Labels..... 3
 Operating the Opener Safely 4
 Additional Information and Potential Changes..... 5

CHAPTER 3 - SETTING UP YOUR EDLUND CROWN PUNCH CAN OPENER 6
 Setup and Operation of the EDLUND CROWN CAN OPENER..... 6
 EDLUND CROWN PUNCH CAN OPENER Controls and Features..... 7

CHAPTER 4 - MAINTAINING THE EDLUND CROWN PUNCH CAN OPENER..... 8
 Adjusting the Head8
 Changing Tooling9
 Crown Punch Cleaning..... 10

CHAPTER 5 - TROUBLESHOOTING..... 11
 Troubleshooting..... 11

CHAPTER 6 - PARTS LISTS, DIAGRAMS, AND WARRANTY 14
 Parts List - CROWN PUNCH CAN OPENER, Models 610M & 610..... 14
 Head Adjustment System - CROWN PUNCH CAN OPENER, Models 610M & 610..... 16
 Warranty..... 23

CHAPTER 1 - INTRODUCING THE EDLUND CROWN PUNCH CAN OPENER

This manual will help you set up and safely operate your new Edlund CROWN PUNCH CAN OPENER. Careful adherence to the safety and operating instructions in this manual will ensure many years of productive use. Please let us know of any questions you may have. To expedite your call, please have your serial number and/or order number handy. **For technical assistance, please call Toll-Free 1-800-772-2126 and one of our Technical Support Representatives will be happy to help you.**

Conventions used in this manual

⚠ WARNING (ORANGE)

THIS INDICATES A POTENTIALLY HAZARDOUS SITUATION, WHICH, IF NOT AVOIDED, COULD RESULT IN DEATH OR SERIOUS INJURY.

⚠ CAUTION (YELLOW)

THIS INDICATES A POTENTIALLY HAZARDOUS SITUATION, WHICH, IF NOT AVOIDED, MAY RESULT IN MINOR OR MODERATE INJURY.

Specifications for the Edlund CROWN PUNCH CAN OPENER, Models 610 & 610M

AIR LINE REQUIRED	85 P.S.I. at 2 C.F.M.
MACHINE DIMENSIONS	See <i>Figure 1</i>
AIR CONNECTION	¼ NPT or Quick Disconnect

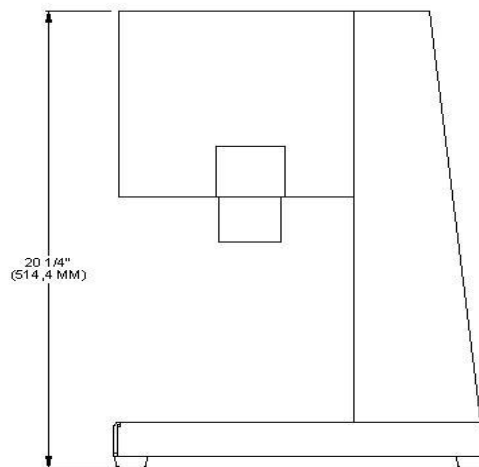
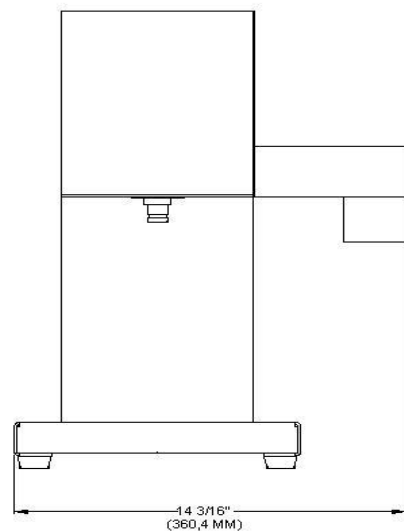
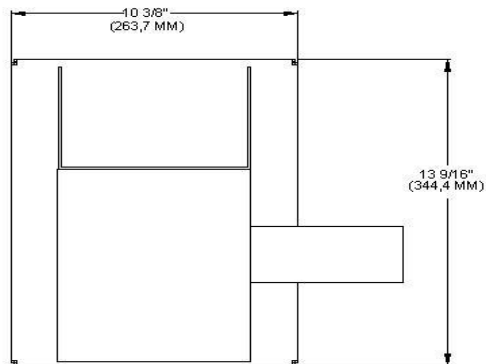

CHAPTER 2 - GENERAL SAFETY RULES

⚠ WARNING

READ THIS SAFETY AND OPERATING MANUAL BEFORE YOU USE THE EDLUND CROWN PUNCH CAN OPENER. BECOME FAMILIAR WITH THE SERVICE RECOMMENDATIONS TO ENSURE THE BEST PERFORMANCE FROM YOUR OPENER.

Labels

Your Edlund CROWN PUNCH CAN OPENER carries prominent labels as reminders for its proper and safe use. Shown below are copies of all the labels that appear on the equipment. Take a moment to study them and make a note of their location on your Edlund CROWN PUNCH CAN OPENER *before* you operate the Opener. Replace damaged or missing safety and information labels immediately.

PROCEDURE TO CLEAN AFTER EACH USE

- 1) Disconnect air, unlock and remove input guard.
- 2) Wear hand protection for knife and lid handling.
- 3) Remove knife and guard ring. To prevent blade damage, support knife with one hand while removing the retaining clip and knife. Check knife for damage that may cause slivers. Send to factory for repairs.
- 4) Wash food contact area and outer surfaces with mild soap and water to clean and protect machine. The knife can be sanitized in a dishwasher.
- 5) Replace knife, clip, guard ring and input guard before the air is reconnected. The can opener can now be tested for operation.

L213

Cleaning #L213



Warning #L316



Read Manual #L228



Cut Hazard #L229

Operating the Opener Safely

WARNING

THIS IS A POWERFUL MACHINE. YOU MUST OPERATE THE OPENER SAFELY. THIS MACHINE CAN CUT AND SEVER PARTS OF YOUR BODY IF THEY BECOME CAUGHT BETWEEN THE CROWN PUNCH/(MAGNET ASSEMBLY, MODEL 610M) AND THE CAN BEING OPENED. ALWAYS TAKE THE FOLLOWING PRECAUTIONS WHEN USING THIS OPENER:

- DO NOT ALLOW ANY PERSON NEAR THE CROWN PUNCH WHILE THE MACHINE IS BEING OPERATED THE FAST, HIGH FORCES OF THE AIR CYLINDER(S) OF THE CROWN PUNCH CAN CAUSE SERIOUS INJURIES. THE LEXAN SPLASH GUARDS MUST BE IN PLACE WHEN OPERATING THE MACHINE. ONLY ONE PERSON SHOULD OPERATE THE CROWN PUNCH MACHINE, USING ONE HAND TO OPERATE EACH GREEN BUTTON TO INSURE THE OPERATOR'S HANDS ARE CLEAR OF THE CROWN PUNCH AREA. THE SAME PERSON OPERATING THE CROWN PUNCH MACHINE SHOULD BE THE INDIVIDUAL LOADING AND REMOVING CANS.
 - ALWAYS DISCONNECT THE AIR LINE WHEN CLEANING, INSTALLING OR REMOVING TOOLING, REPAIRING OR ADJUSTING THE MACHINE.
 - INSPECT THE CROWN PUNCH TOOLING DAILY FOR DENTS, DEFORMITIES, BROKEN WELDS, NICKS, BURRS OR BENT TEETH.
 - INSPECT THE CROWN PUNCH MACHINE DAILY BEFORE AND AFTER USE OR WHEN MAKING ADJUSTMENTS FOR THE FOLLOWING:
 - 1) INSPECT FOR LOOSE HARDWARE.
 - 2) INSPECT THE KNOCK OUT PINS FOR STRAIGHTNESS AND ALIGNMENT TO THE CLEARANCE HOLES IN THE BACK PLATE OF THE CROWN PUNCH. MAKE SURE THE HARDWARE IS TIGHT.
 - 3) INSURE ALL COVERS AND GUARDS ARE IN PLACE.
 - 4) THE GUARD RING MOUNTING HARDWARE MUST BE TIGHTENED BEFORE OPERATION.
 - 5) INSURE THE CROWN PUNCH MACHINE IS SANITIZED BEFORE OPERATION.
 - DO NOT, UNDER ANY CONDITIONS, REMOVE, BEND, CUT, FIT, WELD, OR OTHERWISE ALTER STANDARD PARTS ON THE EDLUND CROWN PUNCH CAN OPENER. MODIFICATIONS TO YOUR MACHINE COULD CAUSE PERSONAL INJURIES AND WILL VOID YOUR WARRANTY.
 - DO NOT OPERATE THE MACHINE WHEN UNDER THE INFLUENCE OF ALCOHOL, DRUGS, OR MEDICATION.
-

⚠ CAUTION

THIS IS A POWERFUL MACHINE. THE OPENER MUST BE OPERATED SAFELY TO PREVENT OR MINIMIZE THE RISK OF MINOR OR MODERATE INJURY. UNSAFE OPERATION MAY RESULT IN A NUMBER OF HAZARDOUS CONDITIONS. ALWAYS TAKE THE FOLLOWING PRECAUTIONS WHEN OPERATING THIS MACHINE:

- WE RECOMMEND WEARING PROTECTIVE GOGGLES OR SAFETY GLASSES WITH SIDE SHIELDS WHILE OPENING CANS TO PROTECT YOUR EYES FROM POSSIBLE SPLASHING OF LIQUID FROM THE CAN.
 - WEAR SHOES WHEN USING YOUR EDLUND CROWN PUNCH CAN OPENER TO PREVENT INJURY IN CASE OF A DROPPED CAN.
 - AVOID WEARING LOOSE CLOTHING OR JEWELRY, WHICH CAN CATCH ON THE OPENER'S MOVING PARTS.
-

No list of Warnings and Cautions can be all-inclusive. If situations occur that are not covered by this manual, the operator must apply common sense and operate this Opener in a safe manner.

Additional Information and Potential Changes

The Edlund Company, Inc. reserves the right to discontinue, change, and improve its products at any time without notice or obligation to the purchaser. The descriptions and specifications contained in this manual were in effect at printing. Equipment described within this manual may be optional. Some illustrations may not be applicable to your machine.

CHAPTER 3 - SETTING UP YOUR EDLUND CROWN PUNCH CAN OPENER

This chapter covers the procedures for setting up your new EDLUND CROWN PUNCH CAN OPENER . You may find it helpful to review the Controls and Features in (**Figure 2** on page 7).

Setup and Operation of the EDLUND CROWN CAN OPENER

1. Unpack the crown punch machine. Check for any loose hardware or damage.
2. Before operation, your new crown punch machine should be sanitized. This will involve removal of the tooling for sanitation and wash down of the machine. Review the Cleaning instructions on page 10.
3. Insure the "T" handles are tight. They are located behind the head of the crown punch machine. The height, with the guard ring in place, must be such that when a can is in position under the crown punch, from the can seam to the lip of the guard ring is approximately 1/8 (3,2mm) to 3/16 (4,8mm), (**Figure 3** on page 8).
4. Before starting, always inspect your tooling. The crown punch must be free of nicks, burrs, dents or bent points. The shearing surface must be dull. The guard ring must seat perfectly on the seam of the can being opened. The retaining clip must be flat and not deformed.
5. Insure the crown punch, guard ring and clip are in place properly. The two knurled screws that hold the guard ring in place must be tightened with a flathead screwdriver before operation.
6. Insure the splash guard is on before operation.
7. Connect the air line. The air must be clean and dry. This typically requires a drier on the compressor. A 5 micron filter and coalescing filter are recommended inline before the connection to the crown punch air inlet. The air requirement is 85 psi at 1 to 2 CFM. Note: No additional inline lubrication is required (the cylinders and air valves are already greased).
8. The crown punch is a one person operation. Place the can under the guard ring and seat it against the back of the tab that is slightly lower. Use both hands and press the green buttons at the same time (this insures the operators hands are clear of the opening area). Hold the green buttons in until the can is completely opened and then release. Never double press the green buttons when opening a can.
9. Remove the opened can with both hands.
10. Carefully remove the lid from the top of the product and discard. Avoid the perimeter seam area. (safety gloves are recommended).
11. If the side magnet option is on the crown punch machine (610M), operate the two green buttons as previously explained then move the can under the magnet and raise the can until the magnet snaps the lid up and holds it. The magnet will retract and drop the lid with the opening of the next can.

⚠ CAUTION (YELLOW)

AVOID THE SHARP EDGES OF THE LID. DO NOT ATTEMPT TO REMOVE THE LID FROM THE MAGNET BY HAND.

NOTE: *The crown punch opener is factory adjusted to open a standard #10 can or the particular size can ordered. The crown punch knife should penetrate the can just far enough to remove the lid but not so far as to cause excessive splashing of liquid in the can. If a height adjustment is required, see "Adjusting the Head" in Chapter 4.*

EDLUND CROWN PUNCH CAN OPENER Controls and Features

NOTE: The model shown in Figure 2 may look slightly different from your machine.

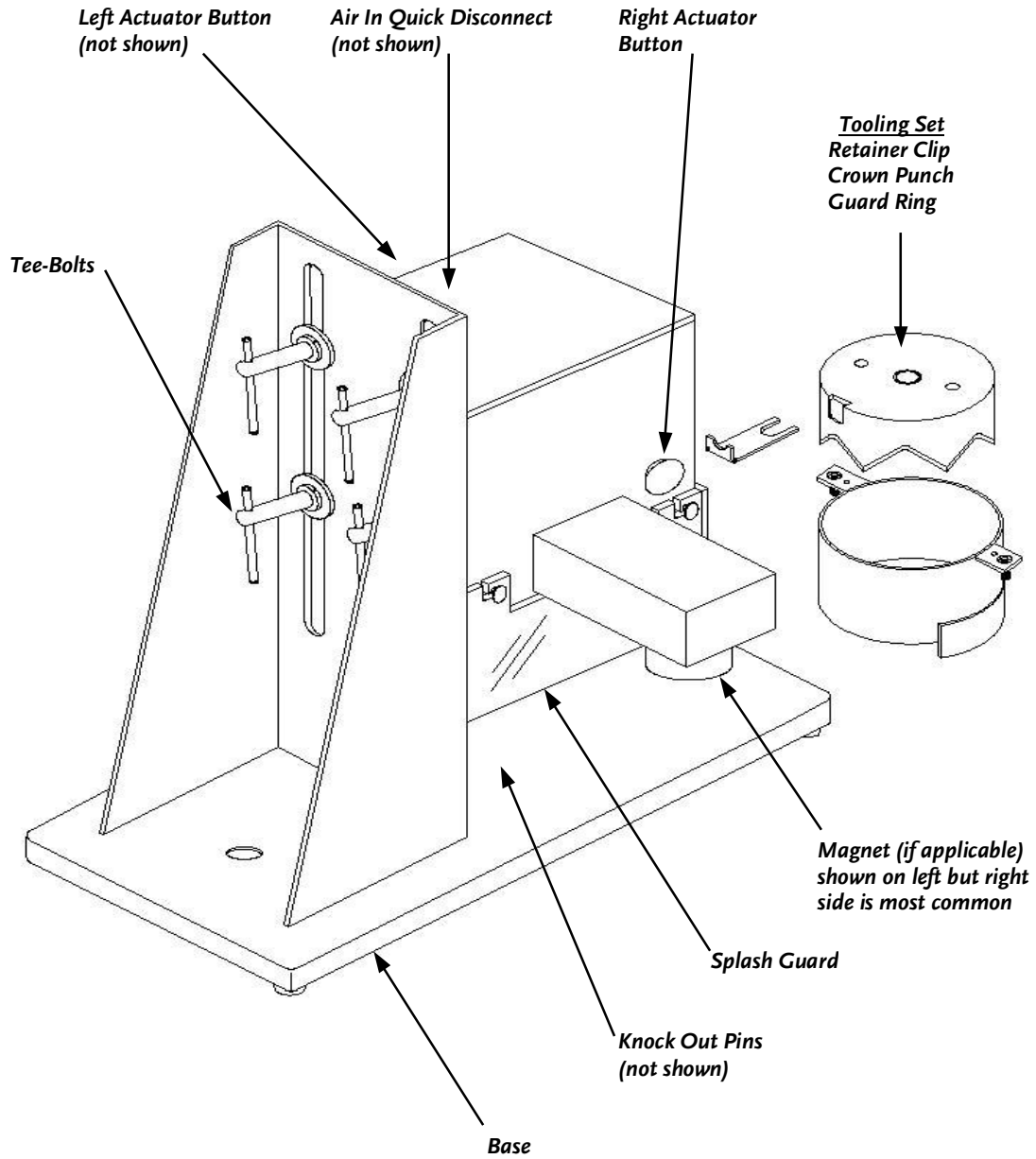

CHAPTER 4 - MAINTAINING THE EDLUND CROWN PUNCH CAN OPENER

This chapter covers regular maintenance procedures that will ensure the best performance and long life of your opener.

Adjusting the Head

⚠ WARNING

BEFORE PERFORMING ANY MAINTENANCE, YOU MUST DISCONNECT THE OPENER FROM THE AIR SUPPLY.

1. Place the can that you want to adjust the machine to below and against the guard ring tab.
2. Loosen the four (4) "T" bolts at the rear of the vertical (**Figure 3**) and raise or lower the Head as needed, keeping the can and guard ring aligned and level.

Tip: Placing a 1/8 to 3/16-inch thick shim between the can and guard ring will help.

3. Tighten the four (4) "T" bolts.

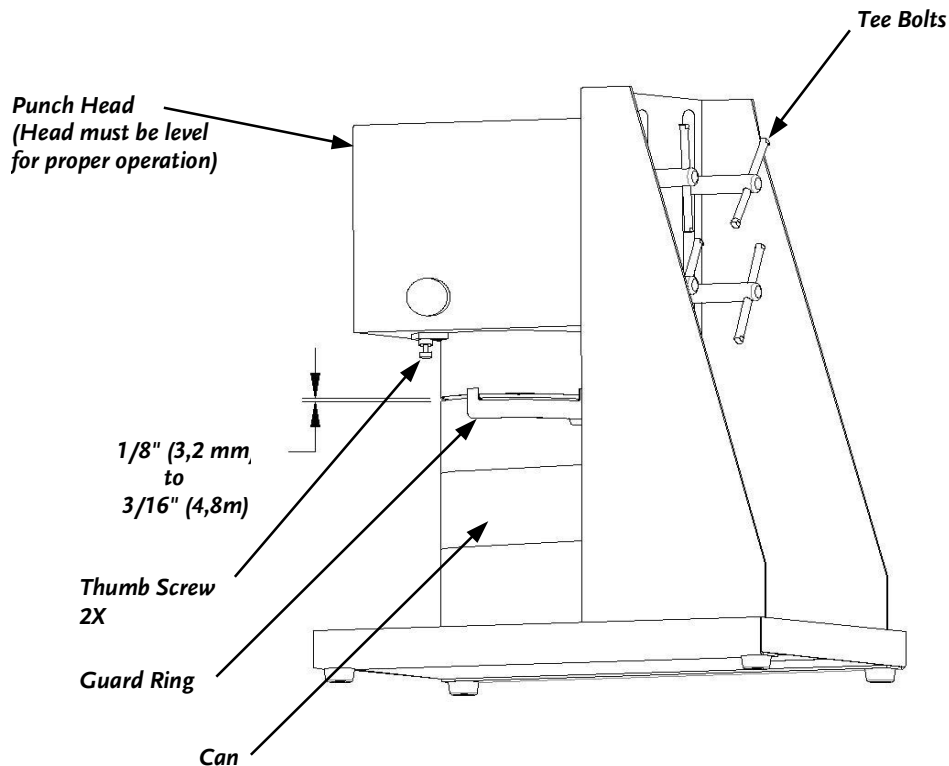

Figure 3

Changing Tooling

To open a different size can, you must use the following procedure to change the Crown Punch.

WARNING

BEFORE PERFORMING ANY MAINTENANCE, YOU MUST DISCONNECT THE OPENER FROM THE AIR SUPPLY.

Tool Needed:

- Flat Head Screwdriver (optional)
1. With one hand, hold up on the guard ring (**Figure 3** on page 8) and with the other hand, unscrew the two (2) Thumbscrews (**Figure 3** on page 8).

Tip: You may need a Flat Head Screwdriver to loosen the screws.

CAUTION

USE CAUTION HANDLING THE CROWN PUNCH IN THE NEXT STEP.

2. Let the guard ring down and set it aside. Now hold up on the crown punch with one hand (being careful of the pointed edges), and with the other hand, pull the retainer clip straight out (**Figure 2** on page 7).

Tip: You may have to wiggle the crown punch to loosen the clip.

3. Set the crown punch and retainer clip down with the guard ring.

NOTE: Do not let the crown punch fall on the base.

4. Install the new crown punch, guard ring and retainer clip in the reverse order.
5. If the lid knockout pins do not align with the holes in the crown punch backing plate, rotate the punch or remove the pins and use the alternate hole locations (can size 400 or smaller).
6. Place the can that you are opening under the guard ring against the tab and adjust the head height described in “adjusting the head” on page 8.
7. Re-connect the air supply.
8. Operate according to “Using and operation of the EDLUND CROWN PUNCH CAN OPENER” on page 6.

Crown Punch Cleaning

WARNING

BEFORE PERFORMING ANY MAINTENANCE, YOU MUST DISCONNECT THE OPENER FROM THE AIR SUPPLY.

Remove the splash guard, crown punch, guard ring, and retainer clip (*Figure 3* on page 8) after every use for cleaning. You may rinse down the entire machine with soap and water to remove any residue from the unit.

CAUTION

USE CAUTION HANDLING THE CROWN PUNCH IN THE NEXT STEP.

1. Remove the tooling per **Changing Tooling** on page 9.
2. Wash down and sanitize the entire splash zone area and any other areas of the machine that may have food contamination on it. Foreign material that remains on the machine will dry and create unsanitary conditions and can affect the performance of the machine. Failure to do so can result in valve and cylinder damage causing costly repairs.
3. Reassemble the crown punch, guard ring, retainer clip, and the splash guard.
4. Be sure all screws are tight.
5. Reconnect the air supply.

TIP: *Cover the air inlet to insure water does not enter the crown punch machine when sanitizing.*

CHAPTER 5 - TROUBLESHOOTING

Consult the Troubleshooting Table below for common problems. If you continue to experience problems, call our Technical Support Representatives at **1-800-772-2126**.

Troubleshooting

WARNING

BEFORE PERFORMING ANY MAINTENANCE, YOU MUST DISCONNECT THE OPENER FROM THE AIR SUPPLY.

The crown punch does not consistently open cans.

- A. Drop in pressure or volume of air: 85psi at 2cfm; clean DRY air required. In most cases this requires a drier on the compressor.
- B. Check the air connection. Air should discharge from the unit when disconnected.
- C. Inspect the edge of the crown punch, it must be smooth with no dings, chips or deformations around the entire circular area, this is the crown punches shearing area. If you should find a slight defect in many cases a light filing can be done, keeping a dull edge. If damage is extensive replace tooling or return it to the Edlund for re-furbishing.
- D. A crown punch must **NEVER** be sharpened. The typical life cycle of a crown punch can be as high as 500,000 cycles. At that point, it will need to be re-surfaced. Inspect your tooling daily for defects and keep the tooling clean.
- E. A crown punch is centered with the can by the guard ring. With the guard ring removed, place your can in the guard ring by placing the can up against the tab of the guard ring, this is the lower piece welded to the ring itself. The can must fit snug in the ring with the bottom edge of the ring sitting on top of the can to be opened. Insure your tooling fits correctly before use.
- F. Dented cans should not be opened on your Edlund crown punch. The results of attempting this could result in tooling or machine damage or the cans failing to open and getting jammed into the tooling. Should this occur, first remove the air supply and remove the can from the tooling. Inspect the tooling for damage and misalignment and correct or replace as needed. If cans are consistently dented a slightly smaller crown punch can be used to help. This method will leave a wider "lip" on the can. EX. 603 can (#10) and guard ring with a 600 crown punch.
- G. Operational errors. In order for the can to be opened properly, the can **MUST BE SEATED** against the back of the guard ring. Crown punches are designed for high volume applications and must be used correctly for proper results.
- H. It is very important to hold in both green buttons through the entire opening cycle. Do not release buttons during cycle and then push the button again to finish. This can result in a "**double pump**" and can misalign the tooling with the can causing tooling and or machine damage.
- I. If the retaining clip should get worn or bent replace it with a new one.
- J. If the mounting studs should become loose or broken (mainly in older machines) replace them or send back to Edlund for repair.

- K. With a can seated in the guard ring, inspect the gap between the guard ring and the top of the can seam. See "**Setup and Operation**", (page 6.)
- L. Insure the large pneumatic cylinder is working properly.
- M. Should a lid remain attached to the can after operating the crown punch, disconnect the air supply. First check the spacing between can and guard ring for proper gap. If this is acceptable, loosen the head of the crown punch with the "T bolts", set the head so it is level with the can. Re-attach the air supply and open another can.

Air is leaking or the crown punch does not move up or down properly.

SERVICE SHOULD ONLY BE PERFORMED BY A QUALIFIED SERVICE TECHNICIAN. Call our Technical Support Representatives at **1-800-772-2126**.

**For all service, warranty or
spare parts requirements,
please call
03 9368 2300**

THIS PAGE INTENTIONALLY LEFT BLANK

CHAPTER 6 - PARTS LISTS, DIAGRAMS, AND WARRANTY

Parts List - CROWN PUNCH CAN OPENER, Models 610M & 610

NOTE: Part numbers listed are available through your authorized parts supplier.

PART #	DESCRIPTION
A019C	ADAPTER, RAM, CLIP FOR ALLEN AIR CYL
A600	WELDMENT, FRAME
A601	WELDMENT, RAM PLATE
A602M	WELDMENT, COVER
A6031	ASSEMBLY, 4 X 1 5/8 CYL W/ MOUNT ONLY
A6035	ASSEMBLY, A6031 CYL. ASSY. W/MOUNT ONLY
A604M	WELDMENT, 610 MAGNET/CYL. MTG. BAR
A720	WELDMENT, #700 GUARD RING, #603 DIA
A756J	WELDMENT, #10 KNIFE S/S
A018	ADAPTER, PUSH BUTTON
B163	BRACKET, COVER
B137B	BUTTON, (BUTTON ONLY)
B132	BUSHING, REDUCTION, 1/4 TO 1/8 NPT
B137	BUTTON, GREEN MUSHROOM PUSH, 800T-D6
B136M	BUSHING, SNAP
BK058	BRACKET, SPLASH GUARD
C084	CLIP, RETAINING #10, 603 SIZE
C103	COUPLING, AIR 1/4" NPT TO MALE
C105	COUPLING, #38224
C124	COVER, FRONT
C137	COVER, TOP
C128D	CYLINDER, UAQ2B225-25
C185	CYLINDER, 4 X 1 5/8 S/S W/ ADAPTER
F003	FASTENER, C.R PUNCH SCREW AND CUP
F009	FITTING, TEE, 1/4 NPT BRANCH
F020	FITTING, TEE, 1/4 NPT
F033	FITTING, SHRT1, PUSH IN 90
F036	FITTING, 1/4" OD PUSH-IN to 1/8 NPT MALE
F037	FITTING, PUSH-IN ELBOW 1/8 NPT TO 1/4 OD HOSE
F038	FITTING, 1/4" Push-in Branch Tee 1/8"
F039	FITTING, 1/4 PUSH-IN RUN TEE
F050	FITTING, 3/8" OD PUSH-IN ELBOW TO 1/4 NPT
F082	FITTING, 1/4 NPT TO 10-32
GR023	SPLASH GUARD, SIDE
GR024	SPLASH GUARD, FRONT
H027	HOSE, 3/8" OD CLEAR PARFLEX
H028	HOSE, 1/4" OD CLEAR
K039	KIT, ROD BUSHING MILLER
K052-94	KIT, CYL 4" MILLER (AFTER 1994)
K075	KIT, STARCYL 1" ROD BUSHING
M003	MAGNET, LARGE
M080	MOUNT, C185 CYLINDER
N008	NIPPLE, 2" LONG

N007	NIPPLE, 1/8 NPT BRASS
P016	PIN, KNOCK OUT
P028	PIN, ROLL
P042	PIN, WELD
PN012	PIN, SPLASH GUARD
R046	RIVET, SB 5-6
S018	SCREW, S/S 1/4-20 X 1 1/4 F.H.C.S
S026	SCREW, S/S 1/2-13 X 1" H.H.C.S
S033	SCREW, S/S 1/2-13 X 3/4 H.H.C.S
S034	SCREW, S/S 1/4-20 X 1 H.H.C.S
S049	SCREW, S/S 10-32 X 3/8 H.H.C.S
S068	SCREW, S/S 10-32 X 1/4 R.H.M
S084	SCREW, S/S 8-32 X 5/16 R.H.M
S096	SCREW, S/S 10-32 X 1 S.H.C.S
S102	SCREW, S/S 8-32 X 1 3/4 S.H.C.S
S349	STANDOFF, CYLINDER
S350	SCREW, 1/2-13 X 2 F.H.C.S
S504	SCREW, S/S 4mm X 10 F.H SLOTTED SCREW
S505	SCREW, S/S 3/8-24 X 1/2 H.H.C.S
S555	SCREW, S/S 10-32 X 2 S.H.C.S
V002	VALVE, 3 WAY NO, MJV0-3
V005	VALVE, 3 WAY NC, MJV-3
V015S	VALVE, SMC 5-WAY DBL. AIR PILOT
V025	VALVE, PV-1P PULSE
W010	WASHER, #10 S/S FLAT
W013	WASHER, 1/2 S/S FLAT
W020	WASHER, 1/4" S/S LOCK
W021	WASHER, #10 S/S LOCK
W024	WASHER, 1/2" S/S LOCK
W029	WASHER, #610/700 12 GA MOUNTING

Head Adjustment System - CROWN PUNCH CAN OPENER, Models 610M & 610

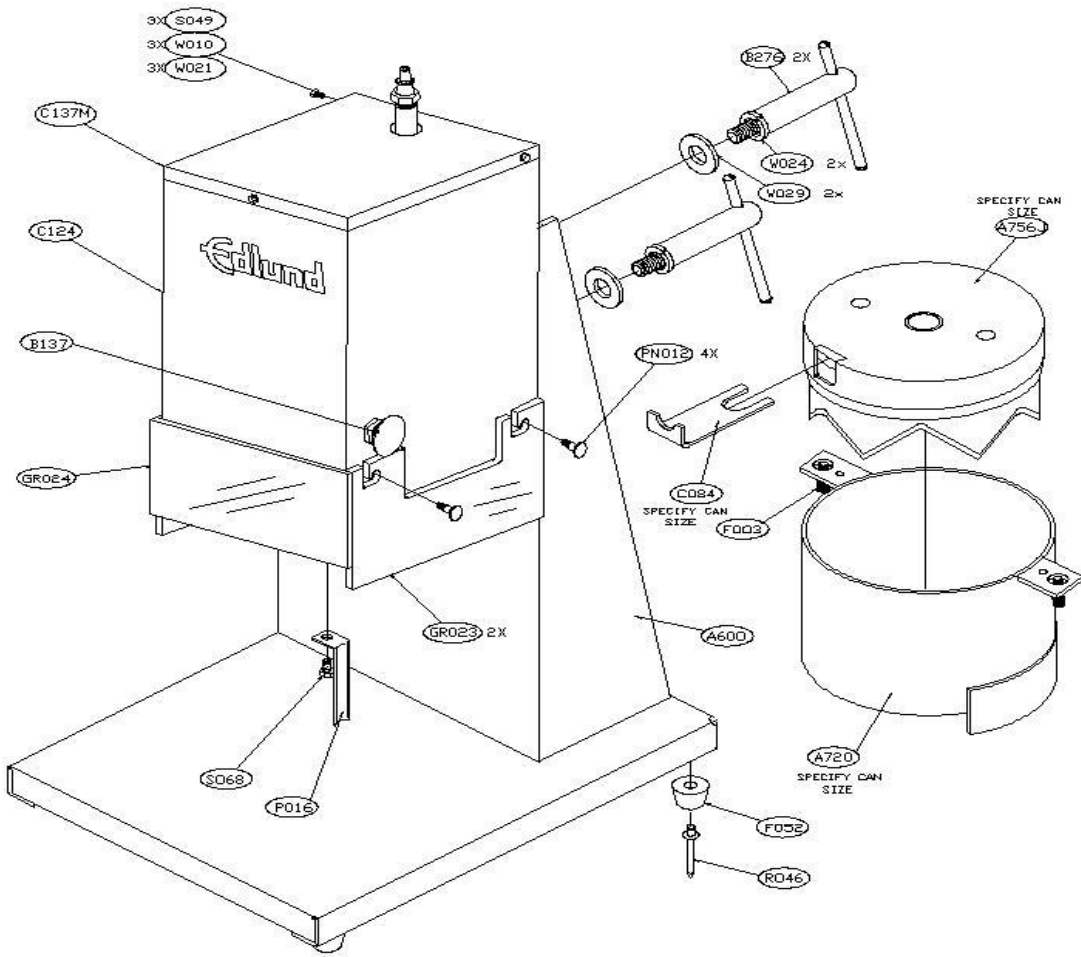

Internal Fittings / Tooling - CROWN PUNCH CAN OPENER, Models 610M & 610

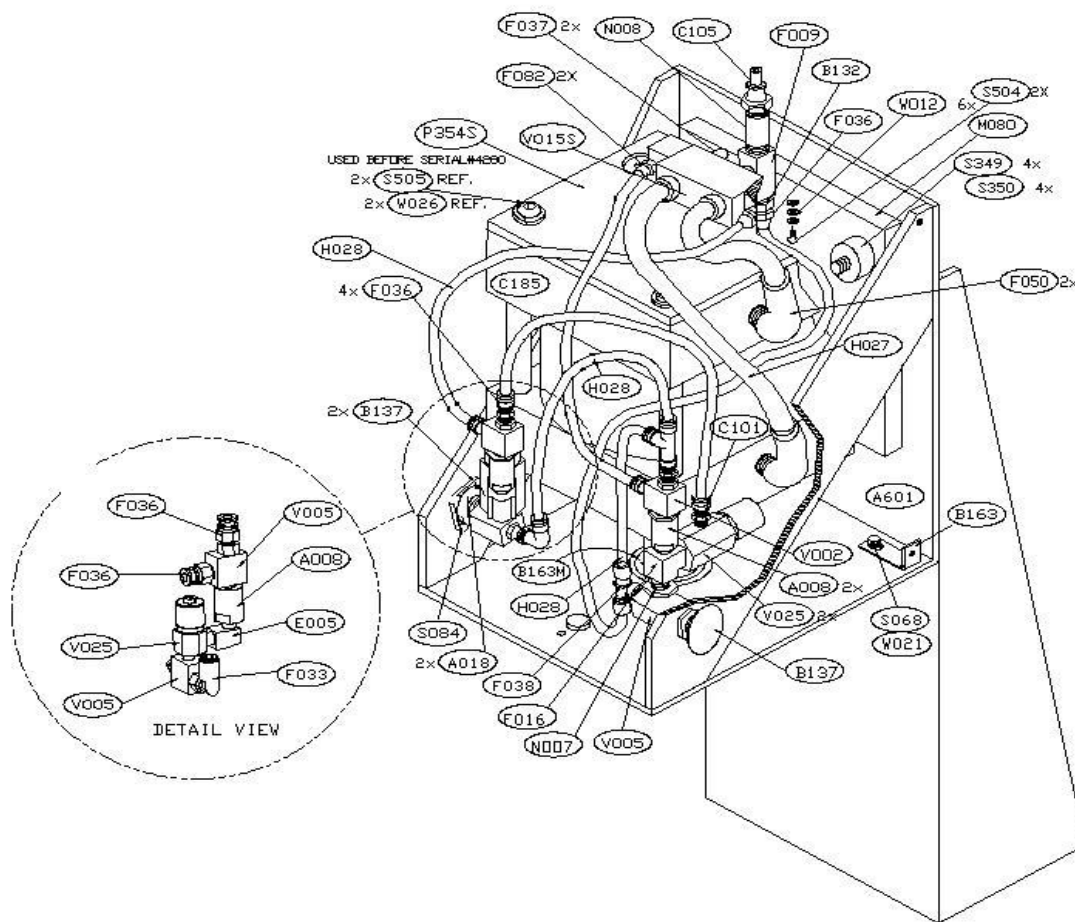

Internal Fittings - CROWN PUNCH CAN OPENER, Models 610M & 610

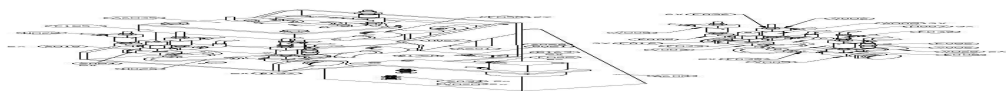
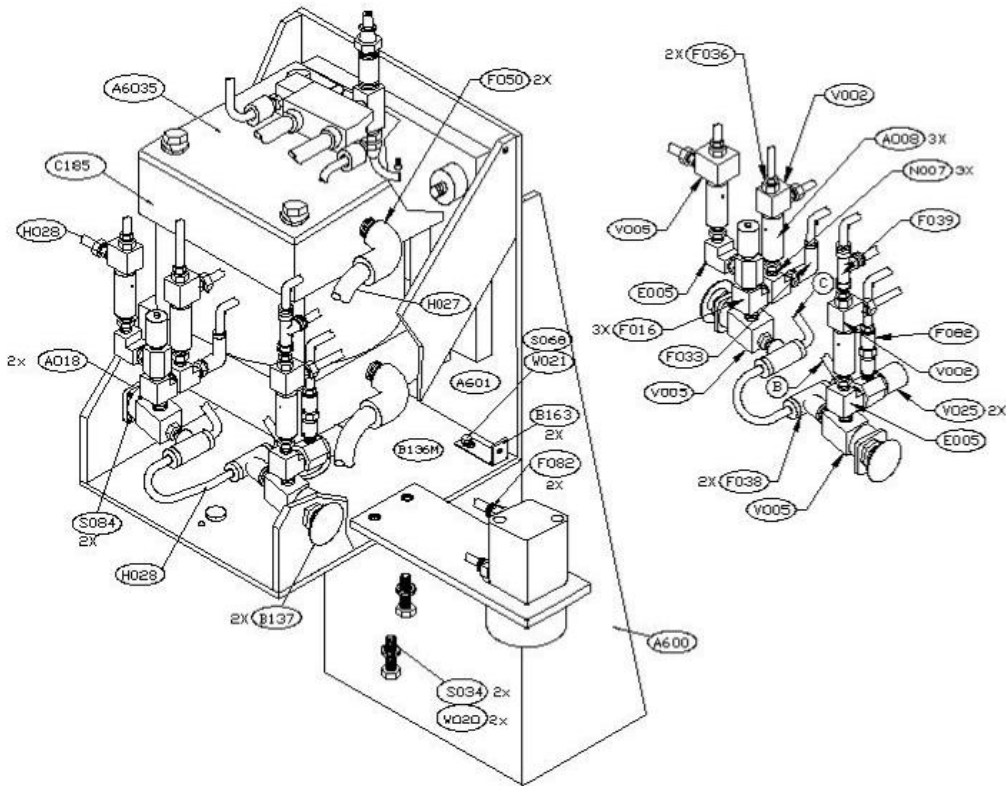

NOTE:

V002 & V005 LOOK SIMILAR.
SEE DESIGNATIONS ON VALVES

V002-NO-MJVO-3

V005-NC-MJV-3

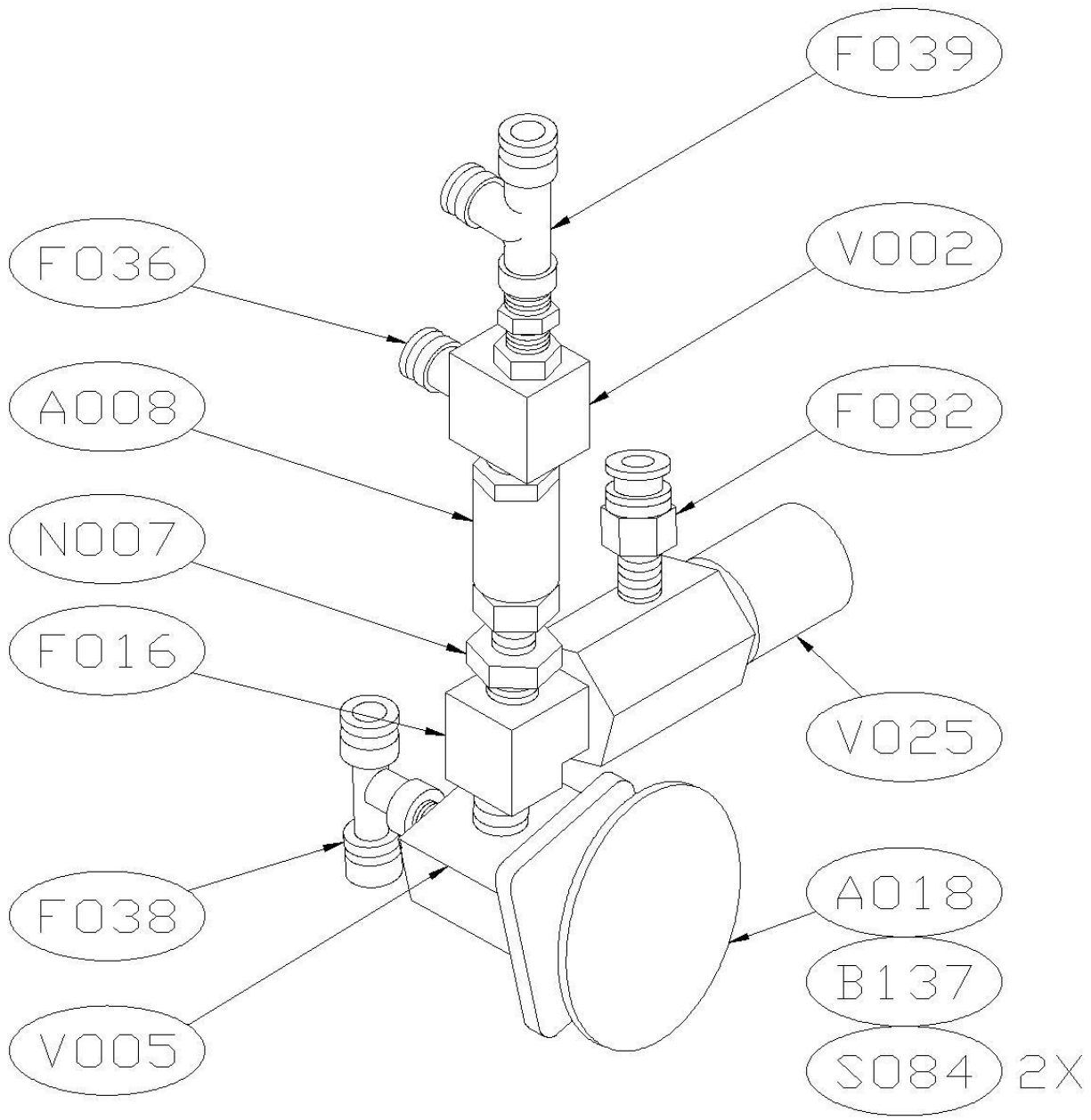

RIGHT SIDE

NOTE:

V002 & V005 LOOK SIMILAR,
SEE DESIGNATIONS ON VALVES

V002-NO-MJV-3

V005-NC-MJV-3

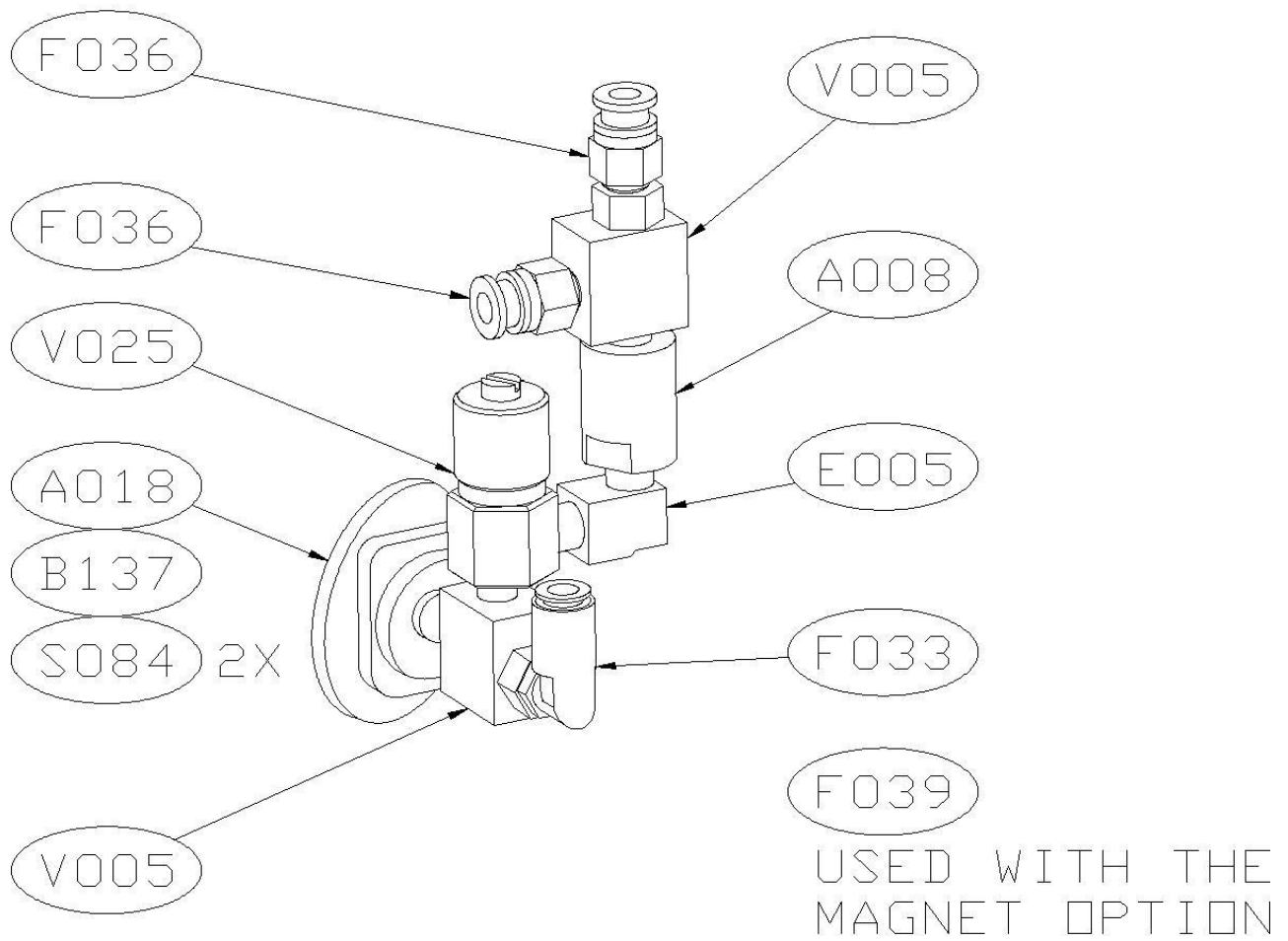

LEFT SIDE

Magnet Assembly - CROWN PUNCH CAN OPENER, Model 610M

Parts List

PART #	DESCRIPTION
A008	ACTUATOR, MIN. PILOT MPA-3P
A6331M	ASSEMBLY, MAGNET AND BRACKET
C128D	CYLINDER, 1 X 1, MAGNET
F036	FITTING, 1/4 OD TO 1/8 NPT
F037	FITTING, 90 ELBOW, 1/4 HOSE TO 1/8 UNI
F082	FITTING, 1/4 NPT TO 10-32
M003	MAGNET, LG.
S018	SCREW, 1/4-28 X 1 1/4 FH SOCKET
S555	SCREW, 10-32 X 2 SOCKET CAP
V002	VALVE, 3 WAY NO, MJV0-3
V025	VALVE, PV-1P PULSE

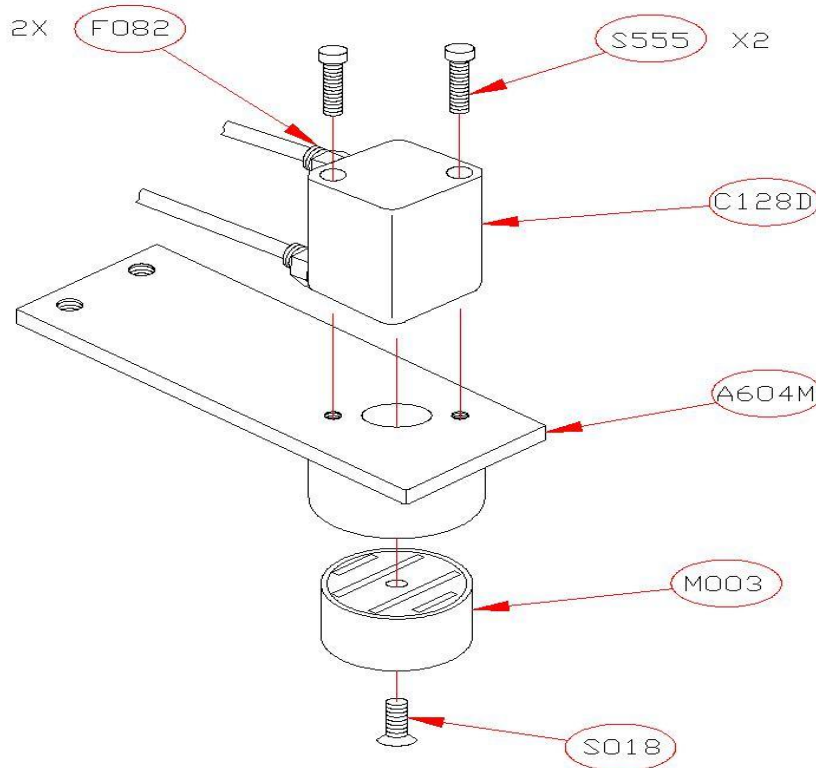

A604M

Pneumatic Schematic - CROWN PUNCH CAN OPENER, Models 610M & 610

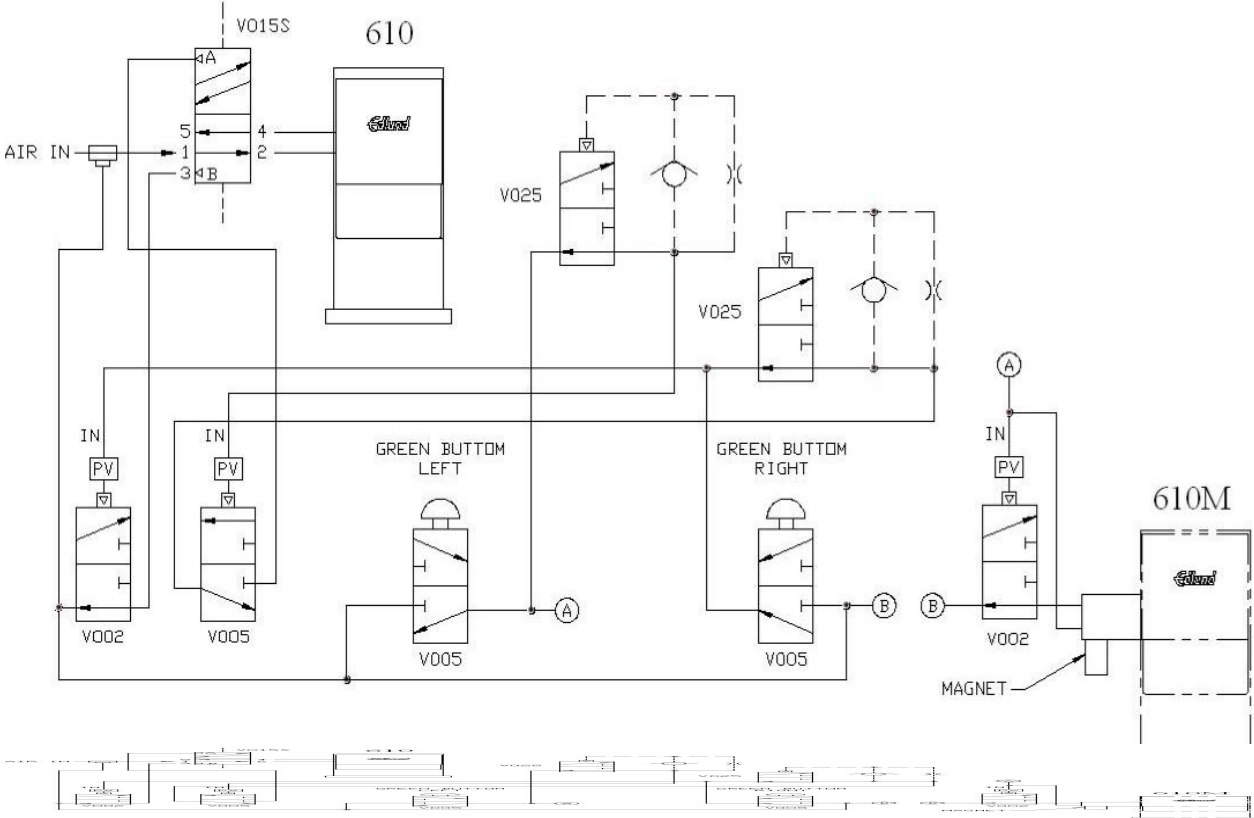



CROWN PUNCH CAN OPENER, Models 610M & 610

WARRANTY:

All Edlund products are guaranteed against defects in material and workmanship for a period of one year from date of purchase, except where specifically noted. The company's obligation under this warranty is limited to repairing or replacing without charge any part or parts found to be defective **under normal use**. It is the responsibility of the purchaser to return the entire unit to the factory, **properly packed, transportation charges prepaid**. This warranty does not cover knives and gears on can openers. No other warranty, written or verbal, is authorized by the company. Warranty charges do not include state, federal, foreign, excise, municipal, or other sales or use taxes. All such taxes are the responsibility of the purchaser.

Carrier is responsible for merchandise in transit to you.

Edlund Company reserves the right to make changes in design or add any improvements on any product. The right is always reserved to modify our equipment because of factors beyond our control and government regulations. Charges to update equipment do not constitute a warranty charge.

The following are not covered under warranty:

1. failure from neglect, abuse, careless handling or mis-application of unit.
2. failure caused by improper maintenance.

Return products to: Edlund Company LLC, Service Department
159 Industrial Parkway, Burlington, VT 05401, USA



Phone: (800) 772-2126 & (802) 862-9661 • Fax: (802) 862-4822