



From one of Europe's leading design and manufacturing facilities comes this remarkable quality range of refrigerated drop-in wells for excellent performance, leading edge style and design.

Ideal for holding and displaying cold food and beverages, this range is available in five models, with lengths of 800, 1125, 1455, 1780 and 2105mm, catering for 2 to 6 GN pans.

The wells are refrigerated by cross-flow cold air and are height adjustable, ranging between 30 to 150mm to suit different food products/display requirements.

For convenience, the evaporator can be lifted up for easy cleaning.

The well is constructed from AISI 304 stainless steel and accommodates 1/1 GN containers.

Includes an easy to use remote digital control system for adjusting temperature, and automatic defrosting.

*Remote condenser models also available.

HEAD OFFICE:

SYDNEY OFFICE:

QUEENSLAND OFFICE:

PERTH:

Drop-in refrigerated units with blown air well

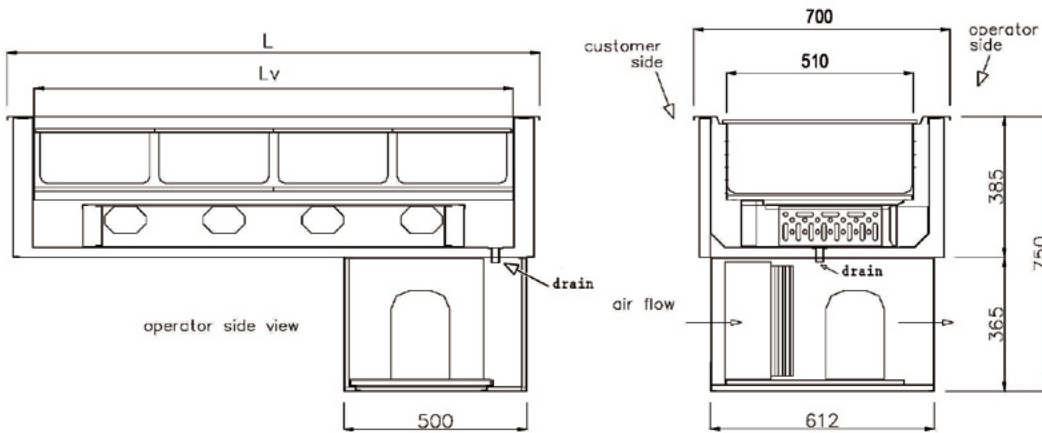

REFRIGERATED VENTILATED WELL						
Model		8046500	8046501	8046502	8046503	8046580
External dimensions [mm]	L = length	800	1125	1455	1780	2105
Well dimensions [mm]	Lv = length	650	980	1310	1630	1960
Capacity GN 1/1 containers		2 GN1/1	3 GN1/1	4 GN1/1	5 GN1/1	6 GN1/1
Well temperature [°C]		+2 to +5	+2 to +5	+2 to +5	+2 to +5	+2 to +5
Refrigerant gas type		R404A	R404A	R404A	R404A	R404A
Cooling power at -10°C [W]		629	869	979	1477	1477
Total Power [Kw]		0.5	0.7	0.9	1.1	1.13
Supply voltage [all 10A GPO]		230V 50Hz	230V 50Hz	230V 50Hz	230V 50Hz	230V 50Hz

*NOTE: For remote condensor models, add an "R" to the above model numbers. (Remote condensing unit not supplied). Unit requires drain waste to tundish/evaporator tray (not supplied).

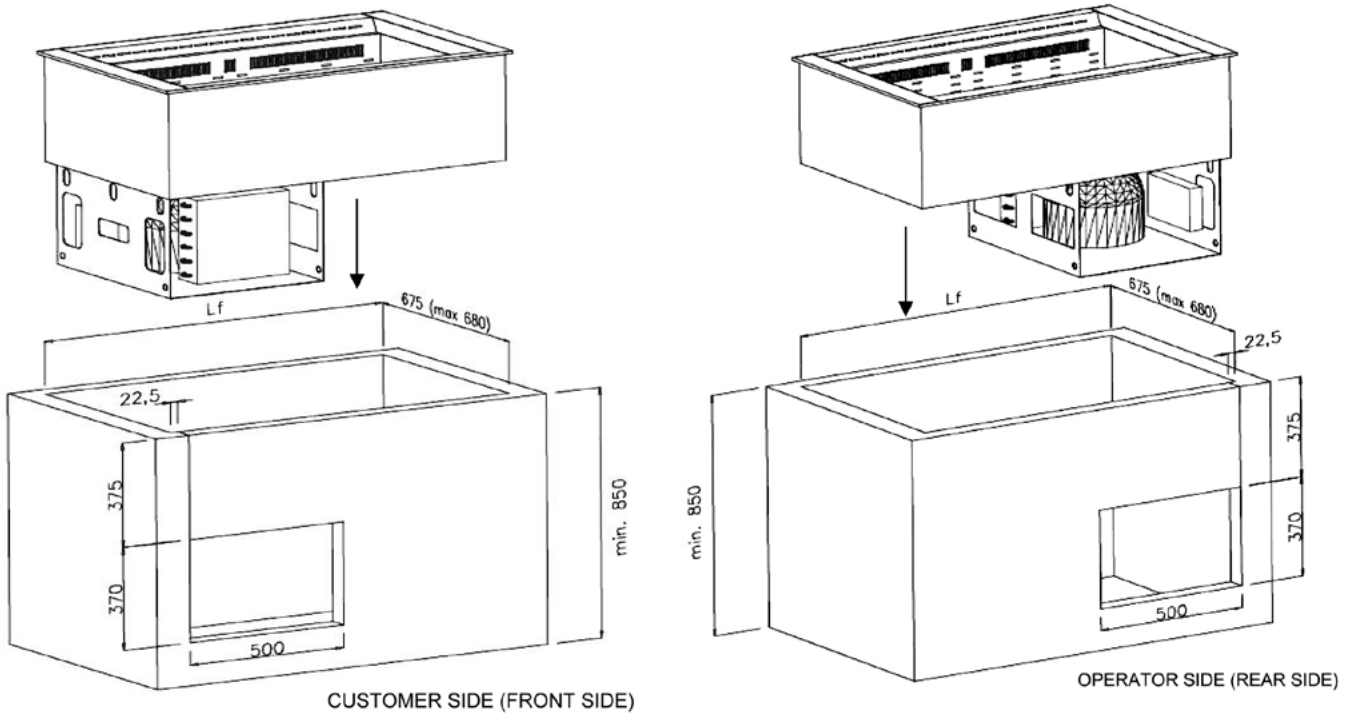

Cutout Dimensions

Gastro Norm	2 GN1/1	3 GN1/1	4 GN1/1	5 GN1/1	6 GN1/1
Length [mm]	775 (max 780)	1100 (max 1105)	1430 (max 1435)	1755 (max 1760)	2080 (max 2085)
Depth [mm]	675 (max 680)	675 (max 680)	675 (max 680)	675 (max 680)	675 (max 680)