



TMS-1H SALAMANDER

POWER WHEN YOU NEED IT

Hatco's Therm-Max® Salamander is specially designed for versatility in the kitchen with the capabilities to cook, grill and reheat food. The unparalleled start-up speed is a result of the "INSTANT ON" heating elements located in the upper housing of the salamander. The Therm-Max Salamander is very energy efficient and easy to operate.



FLEXIBILITY

The heating elements are strategically positioned inside the moveable upper housing to reduce heat transfer to surrounding areas whilst precisely positioning heat over the food product.

The TMS-1H Salamander's left and right heating elements may be operated independently, allowing the benefits of flexibility and energy conservation. Different combinations of elements may be selected to cook the desired quantities of food the way you like.

TMS-1H Salamander includes a HOLD Mode switch that reduces power to 25% saving energy and keeping food at proper serving temperatures.



STANDARD QUALITY FEATURES

- ▶ The high-powered heating elements are ready for use within ten seconds
- ▶ Two independently-controlled heating element sections give the benefits of flexibility and energy conservation
- ▶ Cook mode selection switch controls left, right, or both
- ▶ Made of stainless steel for easy cleaning and durability
- ▶ The Salamander can be placed on a countertop or mounted to a brick or cement wall
- ▶ The TMS-1H includes a hold mode switch that reduces power to 25% and keeps food at proper serving temperatures
- ▶ Units come standard with grill, drip pan and wall mounting bracket

TMS-1H

Moveable upper housing to reduce heat transfer to surrounding areas while precisely positioning heat over the food product. Hold mode saves power.



People who serve, products that solve.™



TMS-1H SALAMANDER

POWER WHEN YOU NEED IT

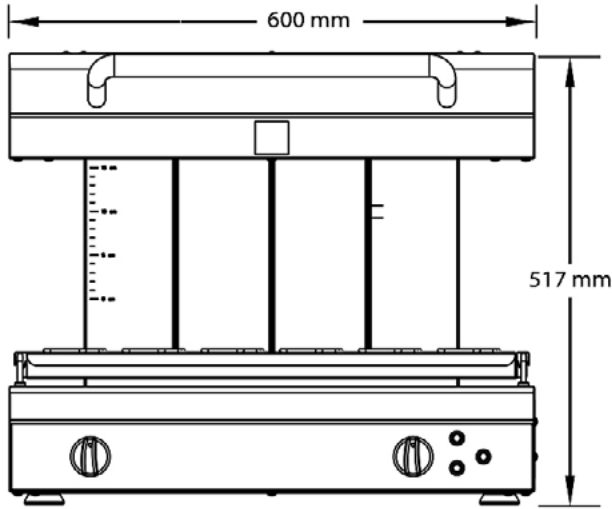

FRONT VIEW

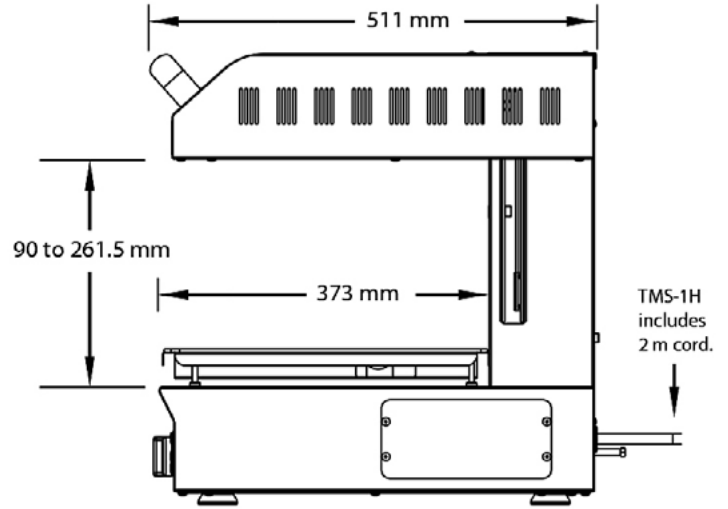

Shown without Wall Mounting Bracket

SIDE VIEW



SPECIFICATIONS

Model	Dimensions (Width x Depth x Height)	Cooking Area (Width x Depth x Height)	Hertz	Volts	Phase	Watts	Amps	Plug	Power Location	Ship Weight*
TMS-1H	600 x 511 x 517 mm	540 x 373 x 90-261 m	50/60	230	Single	4000	17.4	None†	Right side of back, near bottom	70 kg (155 lbs.)

* Shipping weight includes packaging.
 † Power cord is attached without a plug

NOTE: Units are shipped with transport bolt securing the moveable upper housing. This bolt at rear of unit MUST be removed at installation and before use.