



SP Peelers

Faster Cleaner Tougher

i*mc*
fresh thinking



Wall mounted controls

Each unit comes complete with an IP65 rated control box which is quickly and easily mounted to the wall, using a robust stainless steel bracket.

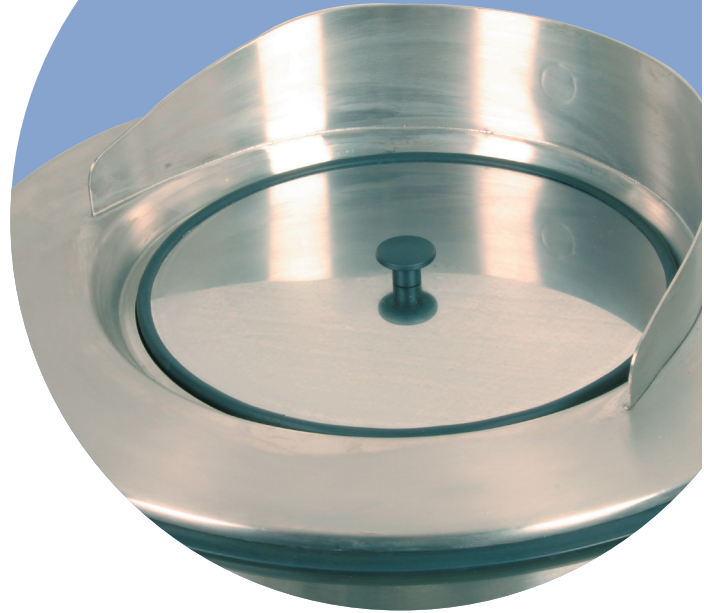

Easier loading

A large hopper opening with a robust lip makes loading quick and easy. The lip is welded to the hopper, to eliminate difficult-to-clean gaps.



Adaptable controls

The SP Peelers can be operated using the timer option – leaving the operator free for other jobs – or set to run continually.

Robust construction

A solid cast aluminium peeler plate, stainless steel chute and hopper, stainless steel water inlet and a tough door mechanism all contribute to a robust machine with a longer working life.

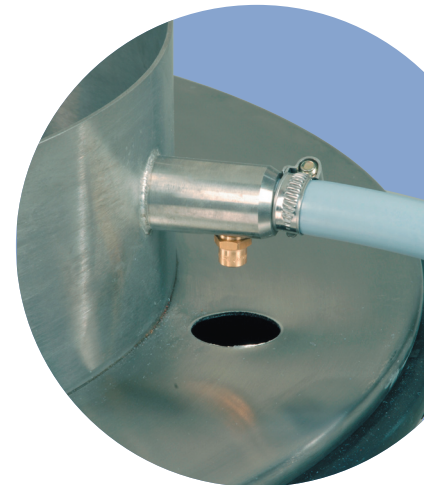

WRAS approved

The robust solid stainless steel water inlet with brass spray nozzle is a WRAS approved class A airbreak and is supplied with a WRAS approved hose.



Energy efficient

Faster peeling means greater energy efficiency and lower water usage – leading to real cost savings.

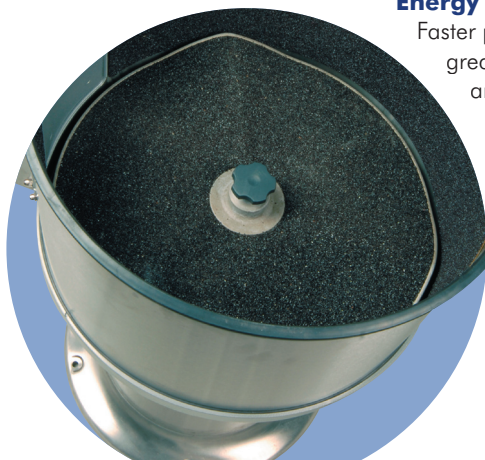

Easier servicing

Incorporating fewer fixings and parts for greater reliability and reduced maintenance.



Faster peeling with a longer lasting peeler

The SP Peelers from IMC are amongst the fastest potato peelers on the market, offering you all the flavour of freshly peeled potatoes, with the speed and convenience of pre-prepared products.

The peelers feature a compact footprint – even the 25kg model takes up a tiny amount of your floor space. And with the SP Peelers being safe and simple to use, you will also minimise your staff time.

And finally, not only are these peelers the easiest and quickest to clean, they're also built to last, with exceptional durability and outstanding reliability. So what you could spend on pre-prepared potatoes in the short term, you can invest in a peeler that will work for you for the long term.

Isn't that appealing?

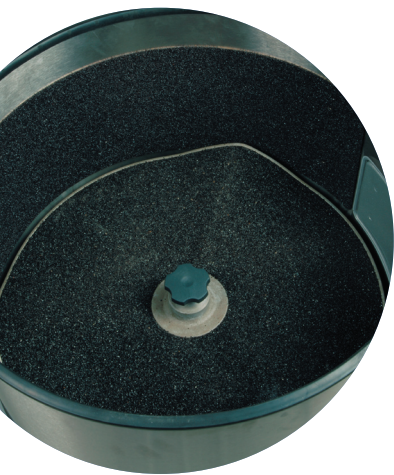

Longer life peeling

The thickly gritted non-rusting cast aluminium peeler plate is designed to be robust and offer a long service life. The carborundum non-rusting stainless steel cylinder liners can be reversed and relined for longer life and lower costs.

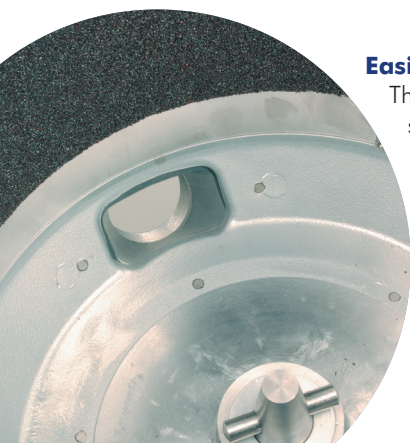

Easier cleaning

The hygienic brushed stainless steel finish is easy to wash down. Water and waste drain efficiently from the smooth cylinder base aided by large cast paddles under the peeler plate. The lid and peeling plate are quick and easy to remove for cleaning.

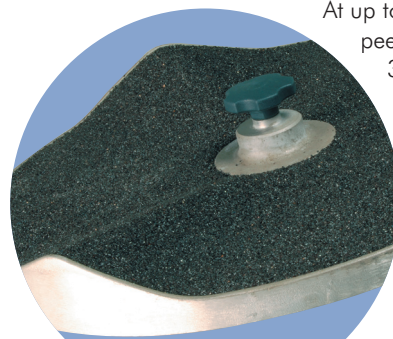

More flexible

With a choice of pedestal heights to fit a tank or catering sink, a flexible hose or plumbed-in waste outlet on either side and the option of an integrated filter basket, an SP Peeler fits easily into your working environment.

Quieter operation

The motor and water inlet both run exceptionally quietly, resulting in an improved working environment, whilst the motor's cooler running temperature ensures optimum performance, efficiency and durability.

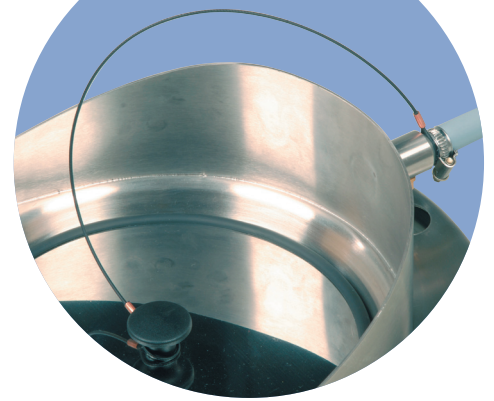

Useful accessories

Available for both models:
Stainless steel, space-saving, integral filter basket.
Stainless steel waste peel interceptor tank.
Silver-finished waste ejector for more effective waste evacuation.
Lid retaining strap.



Faster peeling

At up to 600kg of potatoes peeled per hour, or 5kg in 30 seconds, the SP Peelers are amongst the fastest available, making them ideal wherever high volume potato peeling is required.

SP12

Handling up to 12kg of potatoes per load (equivalent to half a 56lb sack) the SP12 peeler is a cost-effective solution for smaller operations. The corborundum liner acts as a fill guide and the SP12 also features a robust stainless steel lid with secure push fit.

SP12

Mounting	Floor-mounted with low or high pedestal
Capacity	12kg (28lb)
Output	300kg/hour
Dimensions (h x w x d)	low pedestal 1120mm x 530mm x 624mm high pedestal 1400mm x 530mm x 624mm
Discharge height	low pedestal 650mm high pedestal 930mm
Motor	0.37kW (0.5HP)
Fuse rating	15A (1 phase) 5A (3 phase)
Operator controls	Control box (fixed to wall bracket) with on/off button(s), timer and continual run settings
Operator safety	Controls prevent automatic restart if power is cut Low voltage IP65 rated operator controls
Special features	WRAS approved class A airbreak Quick and easy to clean Designed for easy maintenance Hygienic, robust stainless steel and cast alloy construction Rust-proof peeling plate and reversible rust-proof liners Dual position for waste outlet Quiet operation Energy efficient
Customer accessories	Floor standing interceptor tank Integral filter basket Waste ejector for more effective waste evacuation Lid retaining strap



Please note: Capacities are approximate and output may vary depending on the type and age of potatoes used.
All diagram dimensions are in mm.

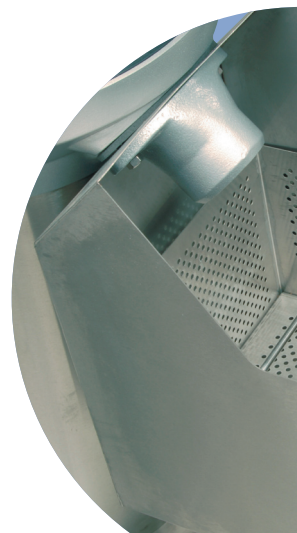
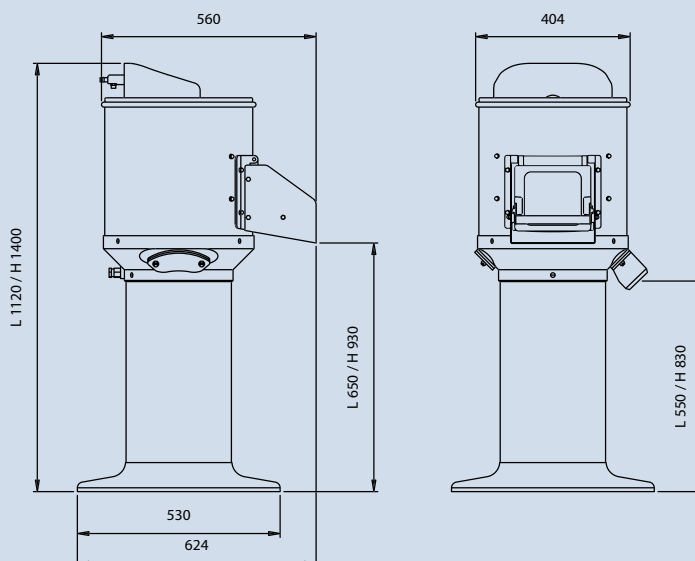

SP25

Handling up to 25kg per load (equivalent to a 56lb sack of potatoes) the SP25 peeler is ideal for larger and busier operations. High grade stainless steel and cast alloy construction ensure durability, combining strength with ease of use and cleaning.

SP25

Mounting	Floor-mounted with low or high pedestal
Capacity	25kg (56lb)
Output	600kg/hour
Dimensions (h x w x d)	low pedestal 1080mm x 564mm x 725mm high pedestal 1360mm x 564mm x 725mm
Discharge height	low pedestal 650mm high pedestal 930mm
Motor	0.75kW (1.0HP)
Fuse rating	15A (1 phase) 5A (3 phase)
Operator controls	Control box (fixed to wall bracket) with on/off button(s), timer and continual run settings
Operator safety	Controls prevent automatic restart if power is cut Low voltage IP65 rated operator controls
Special features	WRAS approved class A airbreak Quick and easy to clean Designed for easy maintenance Hygienic, robust stainless steel and cast alloy construction Rust-proof peeling plate and reversible rust-proof liners Dual position for waste outlet Quiet operation Energy efficient
Customer accessories	Floor standing interceptor tank Integral filter basket Waste ejector for more effective waste evacuation Lid retaining strap



Please note: Capacities are approximate and output may vary depending on the type and age of potatoes used.
All diagram dimensions are in mm.

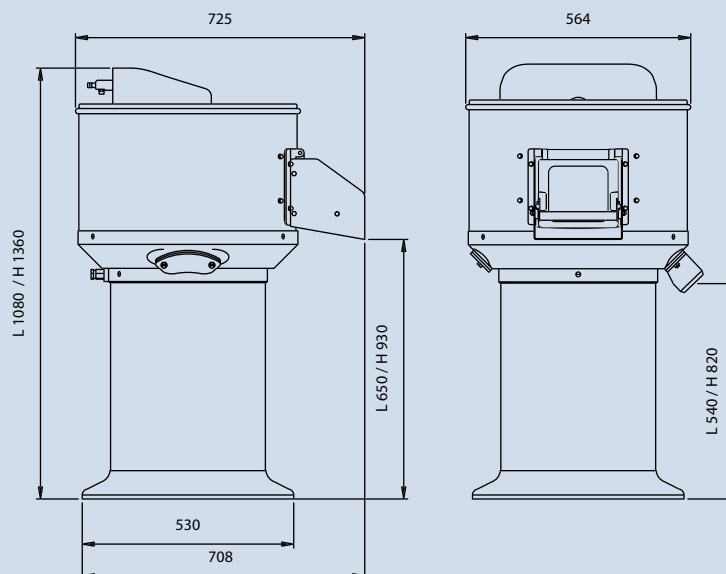



Also available in our vegetable preparation range are the MF multi-functional peeler, VC potato peeler and the PC2 chipper. All are designed for use within the busy kitchen, chip shop or other catering establishments. For more information please contact our sales team.



IMC was founded in 1906 and has since established itself as a leading manufacturer of catering and bar equipment, with a reputation for quality, innovation and unrivalled customer service.



We have the resources, manufacturing expertise, knowledge and skills to provide you with complete waste management and catering solutions and to offer custom built equipment, all of which is designed and manufactured in an ISO9001 approved environment.

Imperial Machine Company Limited

Unit 1 Abbey Road
 Wrexham Industrial Estate
 Wrexham
 LL13 9RF
 United Kingdom

Tel: +44 (0)1978 661155
 Fax: +44 (0)1978 729990
 Email: info@imco.co.uk
www.imc-sp.co.uk

