

TOP VIEW

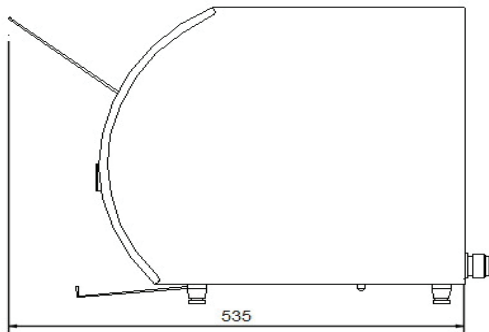

SIDE VIEW  
NTS

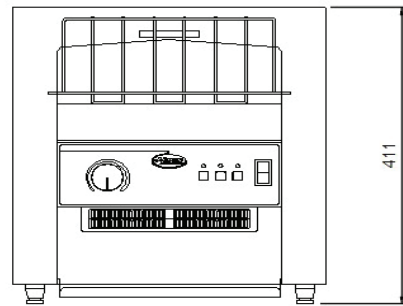

FRONT VIEW

Hatco's industry-leading Toast-Qwik® Conveyor Toasters have been completely redesigned to provide a great new look, and increased production capabilities. They continue to provide the best reliability, flexibility and value of any conveyor toaster available!

**STANDARD FEATURES**

- Patented ColorGuard sensing system which monitors chamber temperature and adjusts conveyor speed to ensure consistent toast results - even in your busiest periods
- Power Save mode activates manually by pressing the Power Save Button above the leaf symbol
- Features an Air Intake Filter Screen which is removable for easy cleaning
- Crumb tray is removable
- 51 mm high opening
- DC stepper motor provides wide range of linear and precise speed control

**SPECIFICATION**

Dimensions	368W x 535D x 411Hmm
Weight	20Kgs
Output Power	1.9 Kw
Power Source	8 amps. Supplied with 10amp plug.