

# Britannia

kitchen ventilation



## Britannia Exhaust Canopies

- Consistently high quality manufacture
- CodeMark Approved
- Manufactured in Australia
- Super efficient grease removal
- Environmental design considerations
- Custom or off-the-shelf canopy solutions
- Engineered to out-perform with lower air volumes
- Wide range of canopy models including custom design and finishes

Tel: 03 8645 2555 E: [sales@fsm-pl.com.au](mailto:sales@fsm-pl.com.au) W: [www.britanniaaustralia.com.au](http://www.britanniaaustralia.com.au)

**FSM**  
Excellence since 1976

# About Britannia...

Britannia has been servicing the European commercial kitchen ventilation market since 1995. Now a market leader, the portfolio contains a long list of fully satisfied customers and end users; a legacy that provides Britannia with an enviable reputation world-wide. From the largest to smallest of projects, Britannia have an engineered solution that will provide excellent performance at competitive rates.

Now in Australia with local manufacturing facilities and a team of skilled professionals, FSM and its partners are again leading the way with innovative solutions for the industry. On the following pages are details of the next revolution in canopy specification - modular sizing with quick selection based on standard module sizes to minimise production time and maximise the ease of specifying/quoting once and for all. This industry-leading initiative will provide faster, easier quoting, less manufacturing cost, and faster turnaround in manufacture - all designed to make you more competitive.

Our normal custom design facility will continue as before for those projects that demand a unique solution.

*All Britannia canopies manufactured in Australia comply with Australian Standard 1668.2-2012 with Codemark Approval originally being granted in June 2011 under Certificate Number CM20049.*

*World-wide, Britannia products are quality controlled to ISO 9001:2008, and exceed DW172 and BS6173 requirements. Britannia is BM Trada compliance certified as well as CHAS (Contractor Health & Safety Assessment Scheme) accredited.*

**13 MONTH  
ON-SITE WARRANTY  
ON ALL BRITANNIA  
CANOPIES**

For more information about Britannia, the product range and full literature with case histories, please visit our website:  
[www.britanniaaustralia.com.au](http://www.britanniaaustralia.com.au)



Find out how a  
Britannia Canopy  
can best fit your  
needs on the  
following pages

## The Britannia Range

The Britannia range of hoods has been developed after years of “in the field” research and development of kitchen hoods. Apart from this real-world input, we have extensively tested & retested products at our own facility as well as many external test procedures on various components. The result of all this work is a hood system based around a group of modularised components which can be configured in multiple ways to create, what to all intents and purposes is a bespoke product. All parts have been designed to achieve a predetermined performance but are specifically not over-engineered. The combination of these properties provides a consistently high quality product, with great flexibility of application and at extremely competitive prices.

- Functional efficiency is paramount and our product range incorporates innovative concepts which help reduce onward running costs in a myriad of ways.
- The range has been carefully designed to provide integral rigidity and to be self supporting - even when disassembled for transportation, so reducing the risks of damage in-transit.
- Only the finest materials, with consistent finish are used in the manufacture process. These are selected & utilised to reflect our concerns for the environment.
- Component sizing has been carefully considered to minimise risk to operatives when lifting, handling & installing.
- Reinforced fixing points have been strategically positioned to minimise site installation times.
- Panels are designed to be rigid so as to prevent drumming.
- Hidden fixings are utilised throughout.

### Grease filtration

All Britstream hoods are equipped with Superstream grease filters as standard. Possibly the single-most important aspect of any kitchen ventilation hood, is the grease filtration; poor filtration drastically increases fire risk & maintenance requirements. For this reason, all Britstream canopies utilise our own highly developed ranges of either Superstream or Ultrastream grease filter panels. These have been tested in Germany to VDI 2052-1 and returned exceptional results at all particle sizes (up to 100% at 5.6 microns) but especially at smaller particle sizes (up to 70% at 3.5 microns) where most grease carry-over is caused and where most other filters fail.

### Spot Cooling

For all supply-air applications as standard, fully adjustable spot cooling is incorporated for operator comfort. This directional air is delivered via smart, matt-black, ABS-moulded terminals in the lower front edge of the hood. Each terminal is easily removed for maintenance & replacement.

### Supply-air Diffusers

Supply-air is typically delivered through the front, outward facing valance of the hood. We have developed a recessed, perforated diffuser panel arrangement with integral filtration to aid air distribution across the full area of the panel. The panels are then tastefully mounted within the front valance and trimmed above and below by a slim bevelled edge formed from the valance itself. Each panel is easily removed for maintenance and replacement and to gain access during the installation process.

### Materials

Hood assemblies are manufactured from type 304 stainless steel. All visible surfaces are fine grain satin polished to meet food hygiene standards. By special agreement, we can manufacture from other stainless steel sheet materials. Plenum ceilings are manufactured from zinc coated mild steel unless specified to the contrary.



## Products

### Britstream ●

Traditional extract only hoods; available in four configurations with standard width or extra wide (for use over combi ovens).

- BE** Extract only - Standard depth
- BER** Extract only - Reduced depth
- BS2** Extract with front Supply & Spot cooling (2)
- BS2R** Extract with front Supply & Spot cooling (2) - Reduced depth

### Capturestream ●

Airstream-induced capture hoods; available in four configurations with standard width or extra wide (for use over combi ovens).

- CS1** Extract with induction Supply (1)
- CS3** Extract with front Supply, Spot cooling & induction Supply (3)
- CS1R** Extract with induction Supply (1) - Reduced depth
- CS3R** Extract with front Supply, Spot cooling & induction Supply (3) - Reduced depth

### Econex ●

Super-efficient, low air-movement, ergonomic, environmentally friendly & available in four configurations with standard width, extra wide (for use over ovens) and super wide (for single sided island arrangements).

- EF** Extract only - Front mounted
- EFB** Extract only - Front & Back mounted
- EFS2** Extract - Front mounted with front Supply & Spot cooling (2)
- EFBS2** Extract - Front & Back mounted with front Supply & Spot cooling (2)

### Dish Wash ●

Efficient capture & management of moisture loaded environments in a single, specialist configuration for all typical wash-up arrangements.

- DWE** Dish Wash Extract

### Other Products ●

**Silverline** Ventilated Ceilings for large kitchens, **Refresh** for installations where no external ducting is possible, and **UV** Grease destruction and Odour reduction without tedious tube cleaning.



## Britstream Extract BE

Extract only - standard depth

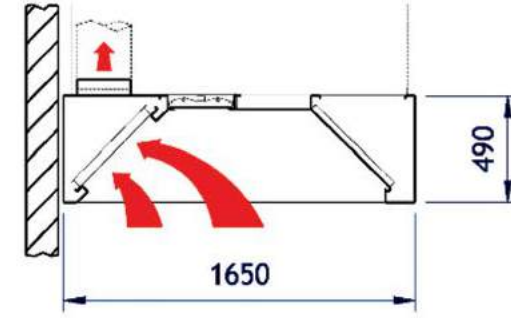
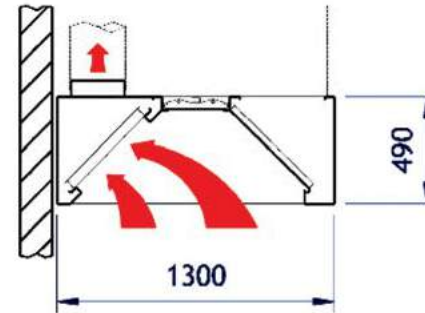

Length (mm)	Max. Extract Volume <sup>2</sup> (l/s)	Light Fittings	Extract Spigots <sup>1</sup> (Qty)	Extract Spigot Dimensions (mm)	Max. Supply Volume (l/s)	Supply Spigots <sup>1</sup> (Qty)	Supply Spigot Dimensions* (mm)	Weight (Kg)
1200	660	1 x 21W Twin Lamp	One	400 x 300	0	None	N/A	80
1375	660	1 x 21W Twin Lamp	One	400 x 300	0	None	N/A	90
1550	880	1 x 28W Twin Lamp	One	500 x 300	0	None	N/A	95
1725	880	1 x 28W Twin Lamp	One	500 x 300	0	None	N/A	105
1900	1100	1 x 35W Twin Lamp	One	600 x 300	0	None	N/A	110
2075	1100	1 x 35W Twin Lamp	One	600 x 300	0	None	N/A	120
2250	1320	1 x 35W Twin Lamp	One	800 x 300	0	None	N/A	125
2425	1320	1 x 35W Twin Lamp	One	800 x 300	0	None	N/A	135
2650	1540	1 x 21W & 1 x 28W Twin Lamp	Two	400 x 300	0	None	N/A	155
2825	1540	1 x 21W & 1 x 28W Twin Lamp	Two	400 x 300	0	None	N/A	165
3000	1760	2 x 28W Twin Lamp	Two	500 x 300	0	None	N/A	170
3175	1760	2 x 28W Twin Lamp	Two	500 x 300	0	None	N/A	180
3350	1980	1 x 28W & 1 x 35W Twin Lamp	Two	600 x 300	0	None	N/A	185
3525	1980	1 x 28W & 1 x 38W Twin Lamp	Two	600 x 300	0	None	N/A	195
3700	2200	2 x 35W Twin Lamp	Two	600 x 300	0	None	N/A	205
3875	2200	2 x 35W Twin Lamp	Two	600 x 300	0	None	N/A	215
4050	2420	2 x 35W Twin Lamp	Two	700 x 300	0	None	N/A	220
4225	2420	2 x 35W Twin Lamp	Two	700 x 300	0	None	N/A	230
4400	2640	2 x 35W Twin Lamp	Two	700 x 300	0	None	N/A	235
4575	2640	2 x 35W Twin Lamp	Two	700 x 300	0	None	N/A	245
4800	2860	2 x 28W & 1 x 35W Twin Lamp	Three	600 x 300	0	None	N/A	260
4975	2860	2 x 28W & 1 x 35W Twin Lamp	Three	600 x 300	0	None	N/A	280
5150	3080	1 x 24W & 2 x 35W Twin Lamp	Three	600 x 300	0	None	N/A	280
5325	3080	1 x 28W & 2 x 35W Twin Lamp	Three	600 x 300	0	None	N/A	300
5500	3300	3 x 35W Twin Lamp	Three	600 x 300	0	None	N/A	295
5675	3300	3 x 35W Twin Lamp	Three	600 x 300	0	None	N/A	315
5850	3520	3 x 35W Twin Lamp	Three	700 x 300	0	None	N/A	310
6025	3520	3 x 35W Twin Lamp	Three	700 x 300	0	None	N/A	330
6200	3740	3 x 35W Twin Lamp	Three	700 x 300	0	None	N/A	325
6375	3740	3 x 35W Twin Lamp	Three	700 x 300	0	None	N/A	345
6550	3960	3 x 35W Twin Lamp	Three	800 x 300	0	None	N/A	340
6725	3960	3 x 35W Twin Lamp	Three	800 x 300	0	None	N/A	360

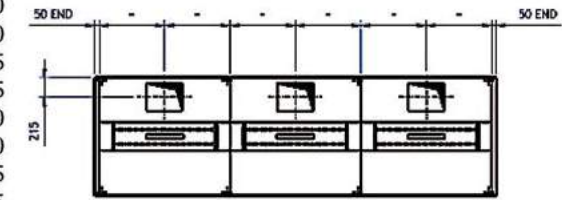
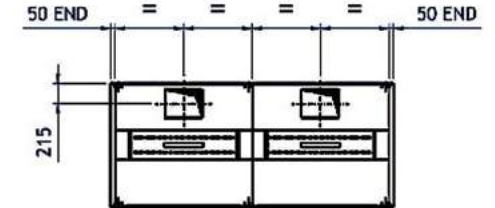
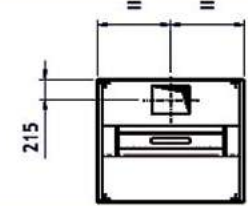

(1) Alternative dimensions / sizes are available upon request.

(2) Maximum Extract Volume base upon use of Superstream baffle type grease filter panels.

# Britstream Extract BE

Wall and island hood configurations

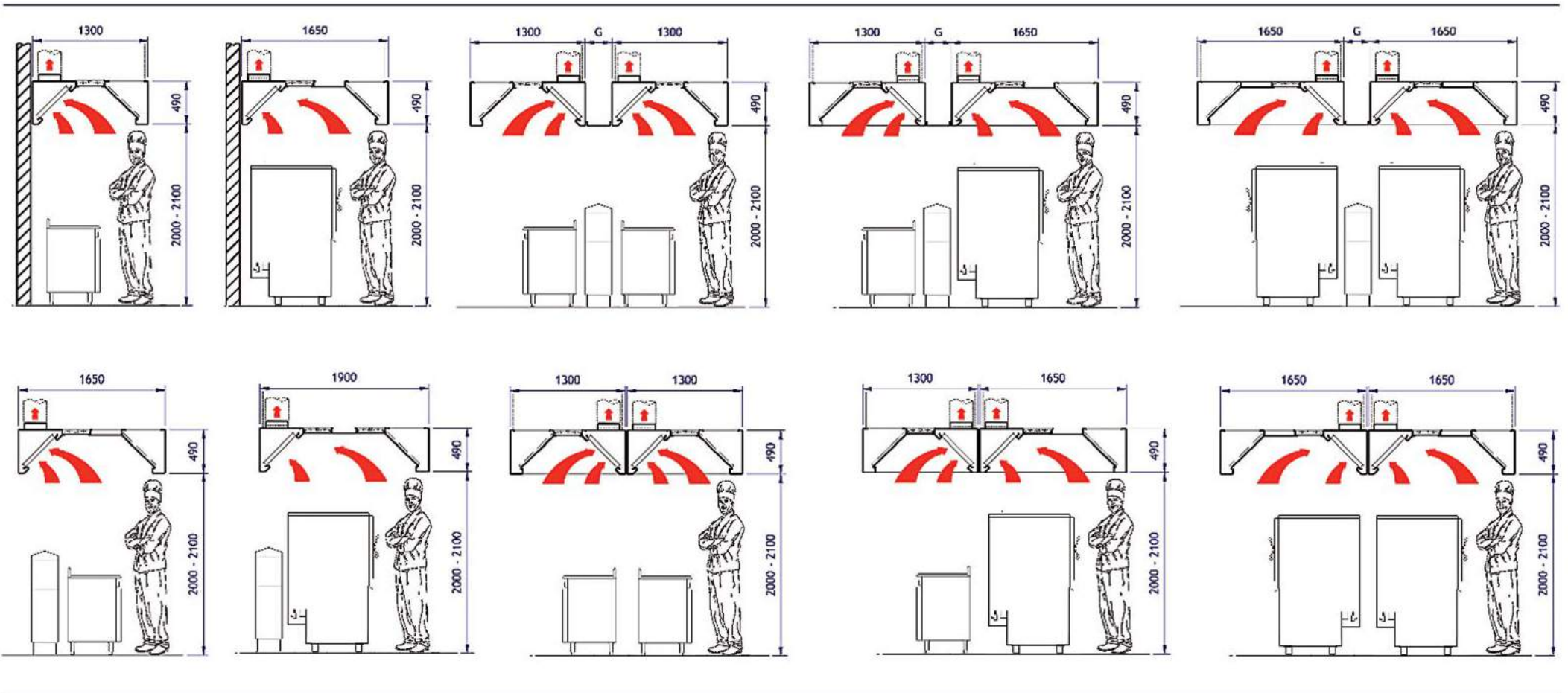



## Britstream Extract BER

Extract only - reduced depth

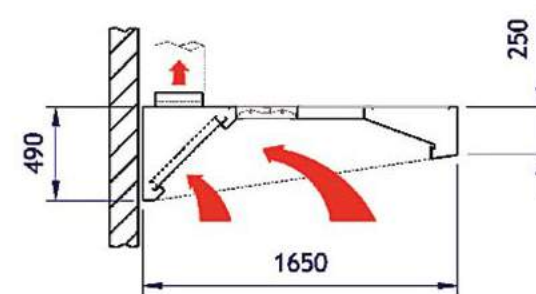
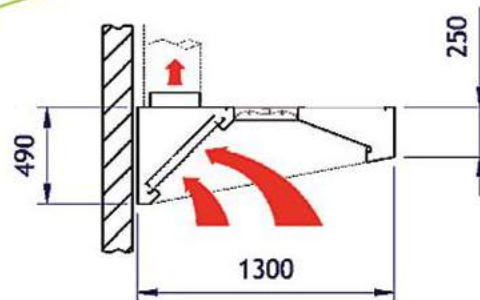

Length (mm)	Max. Extract Volume <sup>2</sup> (l/s)	Light Fittings	Extract Spigots <sup>1</sup> (Qty)	Extract Spigot Dimensions (mm)	Max. Supply Volume (l/s)	Supply Spigots <sup>1</sup> (Qty)	Supply Spigot Dimensions* (mm)	Weight (Kg)
1200	660	1 x 21W Twin Lamp	One	400 x 300	0	None	N/A	80
1375	660	1 x 21W Twin Lamp	One	400 x 300	0	None	N/A	90
1550	880	1 x 28W Twin Lamp	One	500 x 300	0	None	N/A	95
1725	880	1 x 28W Twin Lamp	One	500 x 300	0	None	N/A	105
1900	1100	1 x 35W Twin Lamp	One	600 x 300	0	None	N/A	110
2075	1100	1 x 35W Twin Lamp	One	600 x 300	0	None	N/A	120
2250	1320	1 x 35W Twin Lamp	One	800 x 300	0	None	N/A	125
2425	1320	1 x 35W Twin Lamp	One	800 x 300	0	None	N/A	135
2650	1540	1 x 21W & 1 x 28W Twin Lamp	Two	400 x 300	0	None	N/A	155
2825	1540	1 x 21W & 1 x 28W Twin Lamp	Two	400 x 300	0	None	N/A	165
3000	1760	2 x 28W Twin Lamp	Two	500 x 300	0	None	N/A	170
3175	1760	2 x 28W Twin Lamp	Two	500 x 300	0	None	N/A	180
3350	1980	1 x 28W & 1 x 35W Twin Lamp	Two	600 x 300	0	None	N/A	185
3525	1980	1 x 28W & 1 x 38W Twin Lamp	Two	600 x 300	0	None	N/A	195
3700	2200	2 x 35W Twin Lamp	Two	600 x 300	0	None	N/A	205
3875	2200	2 x 35W Twin Lamp	Two	600 x 300	0	None	N/A	215
4050	2420	2 x 35W Twin Lamp	Two	700 x 300	0	None	N/A	220
4225	2420	2 x 35W Twin Lamp	Two	700 x 300	0	None	N/A	230
4400	2640	2 x 35W Twin Lamp	Two	700 x 300	0	None	N/A	235
4575	2640	2 x 35W Twin Lamp	Two	700 x 300	0	None	N/A	245
4800	2860	2 x 28W & 1 x 35W Twin Lamp	Three	600 x 300	0	None	N/A	260
4975	2860	2 x 28W & 1 x 35W Twin Lamp	Three	600 x 300	0	None	N/A	280
5150	3080	1 x 24W & 2 x 35W Twin Lamp	Three	600 x 300	0	None	N/A	280
5325	3080	1 x 28W & 2 x 35W Twin Lamp	Three	600 x 300	0	None	N/A	300
5500	3300	3 x 35W Twin Lamp	Three	600 x 300	0	None	N/A	295
5675	3300	3 x 35W Twin Lamp	Three	600 x 300	0	None	N/A	315
5850	3520	3 x 35W Twin Lamp	Three	700 x 300	0	None	N/A	310
6025	3520	3 x 35W Twin Lamp	Three	700 x 300	0	None	N/A	330
6200	3740	3 x 35W Twin Lamp	Three	700 x 300	0	None	N/A	325
6375	3740	3 x 35W Twin Lamp	Three	700 x 300	0	None	N/A	345
6550	3960	3 x 35W Twin Lamp	Three	800 x 300	0	None	N/A	340
6725	3960	3 x 35W Twin Lamp	Three	800 x 300	0	None	N/A	360

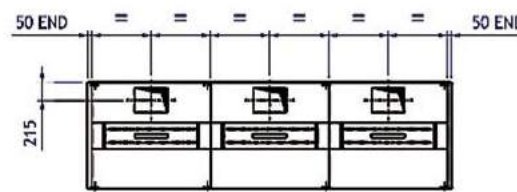
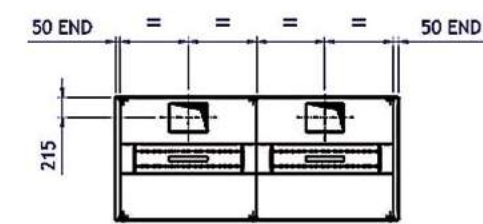
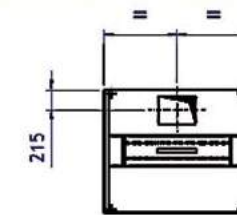

(1) Alternative dimensions / sizes are available upon request.

(2) Maximum Extract Volume base upon use of Superstream baffle type grease filter panels.



# Britstream Extract BER

## Wall and island hood configurations

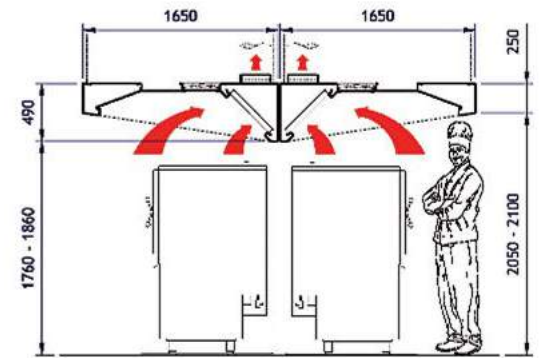
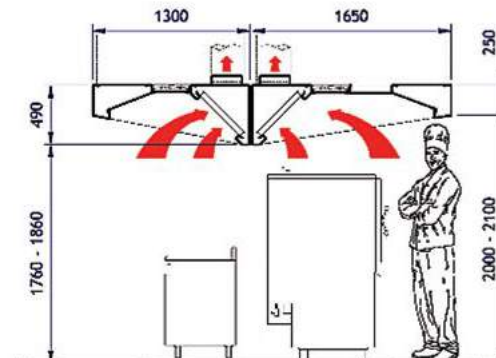
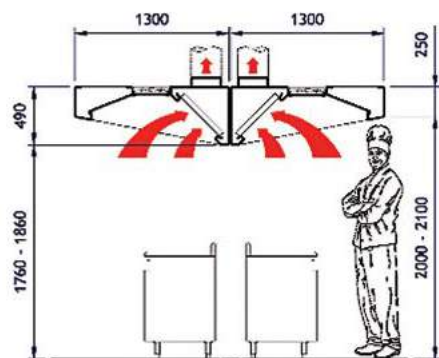
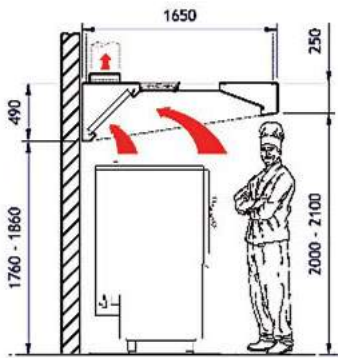
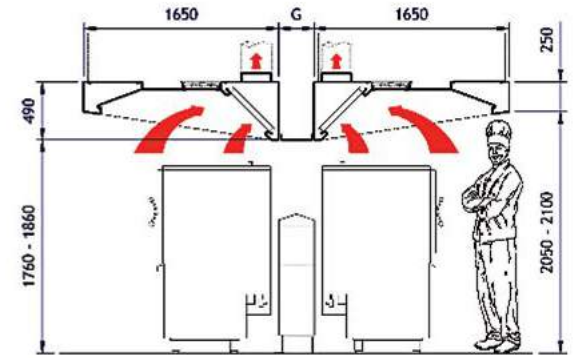
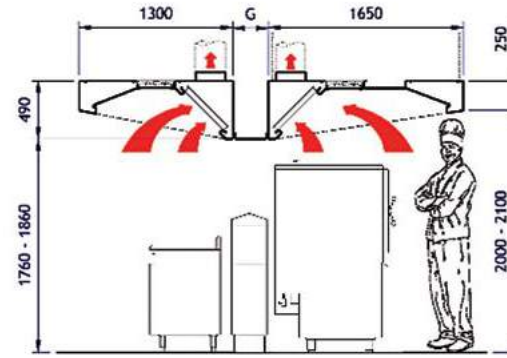
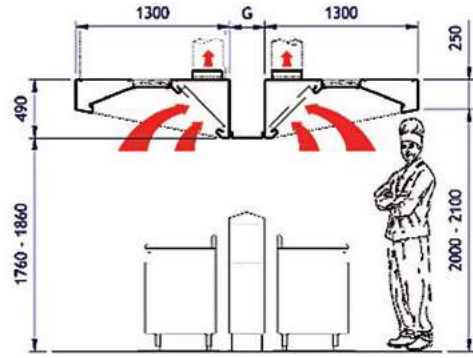
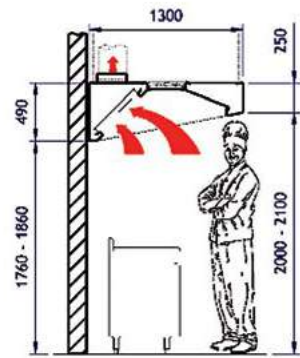

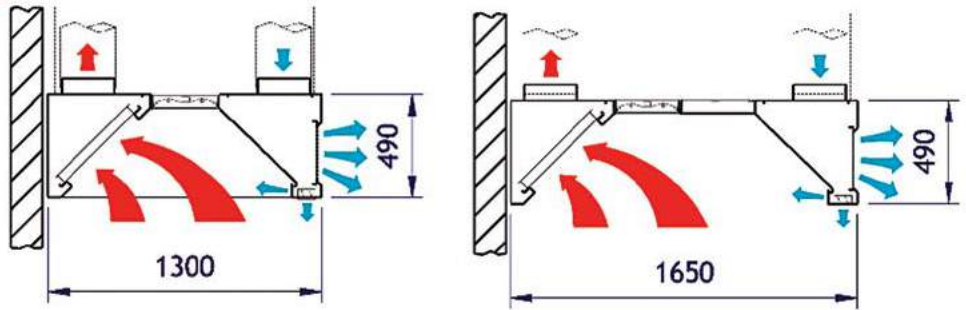
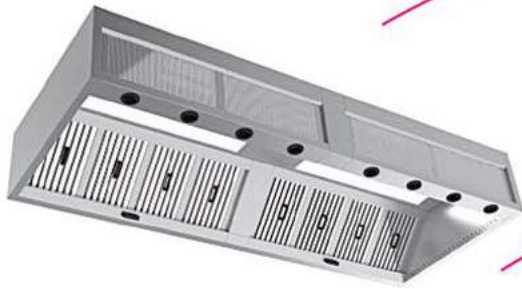

## Capturestream CS3

Extract with front supply & spot cooling & induction supply - standard depth

Length (mm)	Max. Extract Volume <sup>2</sup> (l/s)	Light Fittings	Extract Spigots <sup>1</sup> (Qty)	Extract Spigot Dimensions (mm)	Max. Supply Volume (l/s)	Supply Spigots <sup>1</sup> (Qty)	Supply Spigot Dimensions* (mm)	Weight (Kg)
1200	660	1 x 21W Twin Lamp	One	400 x 300	560	One	400 x 300	80
1375	660	1 x 21W Twin Lamp	One	400 x 300	560	One	400 x 300	90
1550	880	1 x 28W Twin Lamp	One	500 x 300	750	One	500 x 300	105
1725	880	1 x 28W Twin Lamp	One	500 x 300	750	One	500 x 300	115
1900	1100	1 x 35W Twin Lamp	One	600 x 300	935	One	600 x 300	120
2075	1100	1 x 35W Twin Lamp	One	600 x 300	935	One	600 x 300	130
2250	1320	1 x 35W Twin Lamp	One	800 x 300	1120	One	800 x 300	135
2425	1320	1 x 35W Twin Lamp	One	800 x 300	1120	One	800 x 300	145
<hr/>								
2650	1540	1 x 21W & 1 x 28W Twin Lamp	Two	400 x 300	1310	Two	400 x 300	170
2825	1540	1 x 21W & 1 x 28W Twin Lamp	Two	400 x 300	1310	Two	400 x 300	180
3000	1760	2 x 28W Twin Lamp	Two	500 x 300	1495	Two	500 x 300	185
3175	1760	2 x 28W Twin Lamp	Two	500 x 300	1495	Two	500 x 300	195
3350	1980	1 x 28W & 1 x 35W Twin Lamp	Two	600 x 300	1685	Two	600 x 300	205
3525	1980	1 x 28W & 1 x 38W Twin Lamp	Two	600 x 300	1685	Two	600 x 300	215
3700	2200	2 x 35W Twin Lamp	Two	600 x 300	1870	Two	600 x 300	220
3875	2200	2 x 35W Twin Lamp	Two	600 x 300	1870	Two	600 x 300	230
4050	2420	2 x 35W Twin Lamp	Two	700 x 300	2055	Two	700 x 300	235
4225	2420	2 x 35W Twin Lamp	Two	700 x 300	2055	Two	700 x 300	245
4400	2640	2 x 35W Twin Lamp	Two	700 x 300	2245	Two	700 x 300	250
4575	2640	2 x 35W Twin Lamp	Two	700 x 300	2245	Two	700 x 300	260
<hr/>								
4800	2860	2 x 28W & 1 x 35W Twin Lamp	Three	600 x 300	2430	Three	600 x 300	285
4975	2860	2 x 28W & 1 x 35W Twin Lamp	Three	600 x 300	2430	Three	600 x 300	305
5150	3080	1 x 24W & 2 x 35W Twin Lamp	Three	600 x 300	2620	Three	600 x 300	305
5325	3080	1 x 28W & 2 x 35W Twin Lamp	Three	600 x 300	2620	Three	600 x 300	325
5500	3300	3 x 35W Twin Lamp	Three	600 x 300	2805	Three	600 x 300	320
5675	3300	3 x 35W Twin Lamp	Three	600 x 300	2805	Three	600 x 300	340
5850	3520	3 x 35W Twin Lamp	Three	700 x 300	2990	Three	700 x 300	335
6025	3520	3 x 35W Twin Lamp	Three	700 x 300	2990	Three	700 x 300	355
6200	3740	3 x 35W Twin Lamp	Three	700 x 300	3180	Three	700 x 300	355
6375	3740	3 x 35W Twin Lamp	Three	700 x 300	3180	Three	700 x 300	375
6550	3960	3 x 35W Twin Lamp	Three	800 x 300	3365	Three	800 x 300	370
6725	3960	3 x 35W Twin Lamp	Three	800 x 300	3365	Three	800 x 300	390

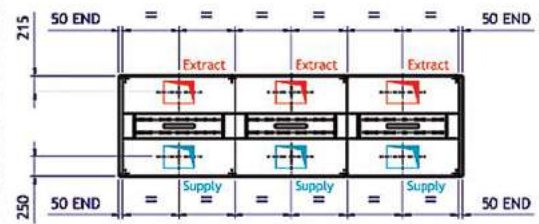
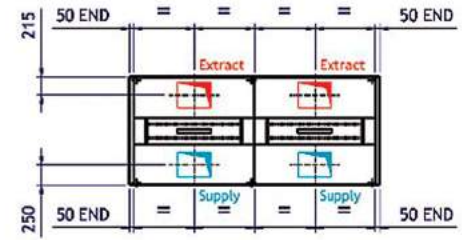
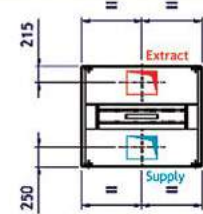

(1) Alternative dimensions / sizes are available upon request.  
 (2) Maximum Extract Volume base upon use of Superstream baffle type grease filter panels.

# Capturestream CS3

## Wall and island hood configurations

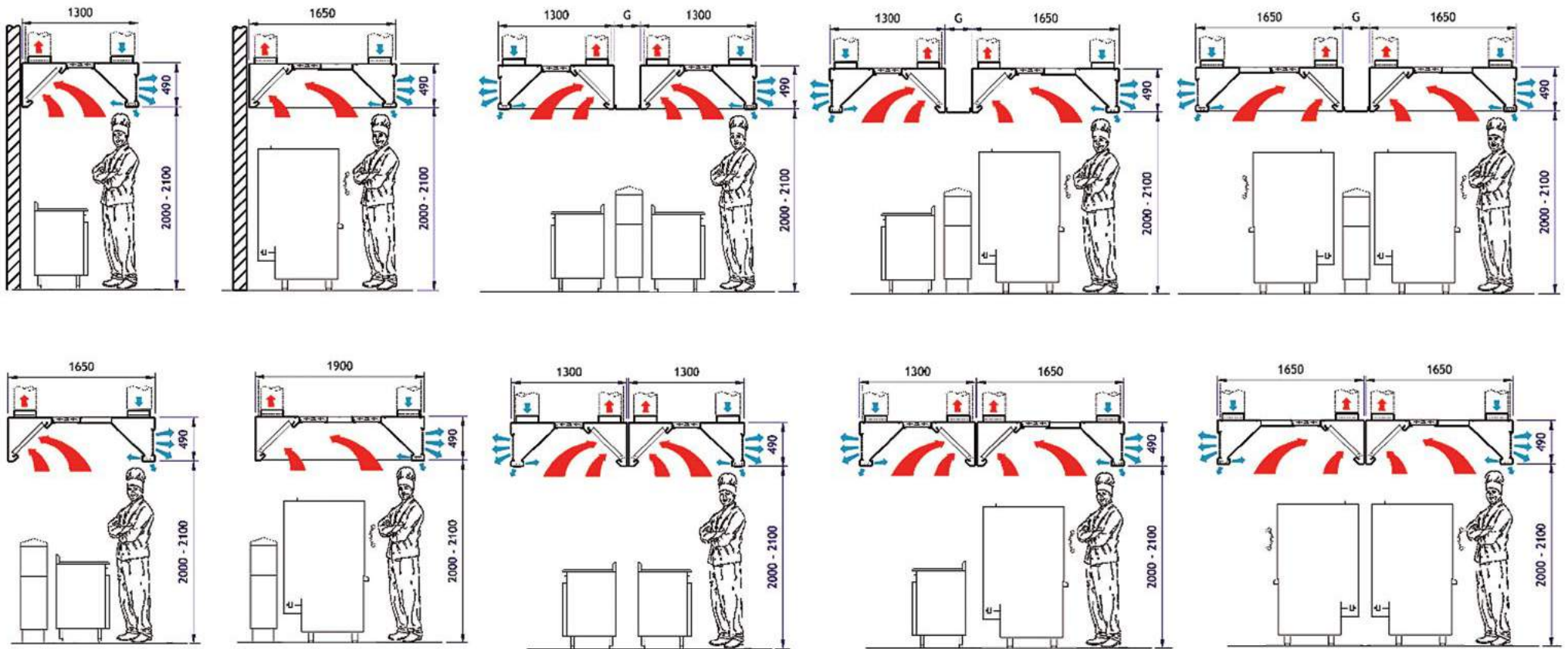

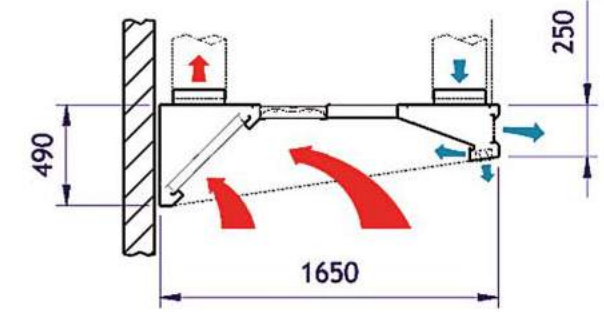
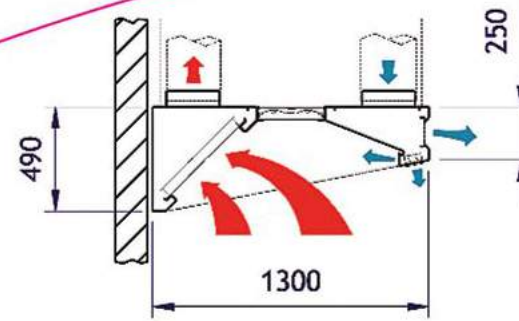

## Capturestream CS3R

Extract with front supply & spot cooling & induction supply - reduced depth

Length (mm)	Max. Extract Volume <sup>2</sup> (l/s)	Light Fittings	Extract Spigots <sup>1</sup> (Qty)	Extract Spigot Dimensions (mm)	Max. Supply Volume (l/s)	Supply Spigots <sup>1</sup> (Qty)	Supply Spigot Dimensions* (mm)	Weight (Kg)
1200	660	1 x 21W Twin Lamp	One	400 x 300	560	One	400 x 300	80
1375	660	1 x 21W Twin Lamp	One	400 x 300	560	One	400 x 300	90
1550	880	1 x 28W Twin Lamp	One	500 x 300	750	One	500 x 300	105
1725	880	1 x 28W Twin Lamp	One	500 x 300	750	One	500 x 300	115
1900	1100	1 x 35W Twin Lamp	One	600 x 300	935	One	600 x 300	120
2075	1100	1 x 35W Twin Lamp	One	600 x 300	935	One	600 x 300	130
2250	1320	1 x 35W Twin Lamp	One	800 x 300	1120	One	800 x 300	135
2425	1320	1 x 35W Twin Lamp	One	800 x 300	1120	One	800 x 300	145
2650	1540	1 x 21W & 1 x 28W Twin Lamp	Two	400 x 300	1310	Two	400 x 300	170
2825	1540	1 x 21W & 1 x 28W Twin Lamp	Two	400 x 300	1310	Two	400 x 300	180
3000	1760	2 x 28W Twin Lamp	Two	500 x 300	1495	Two	500 x 300	185
3175	1760	2 x 28W Twin Lamp	Two	500 x 300	1495	Two	500 x 300	195
3350	1980	1 x 28W & 1 x 35W Twin Lamp	Two	600 x 300	1685	Two	600 x 300	205
3525	1980	1 x 28W & 1 x 38W Twin Lamp	Two	600 x 300	1685	Two	600 x 300	215
3700	2200	2 x 35W Twin Lamp	Two	600 x 300	1870	Two	600 x 300	220
3875	2200	2 x 35W Twin Lamp	Two	600 x 300	1870	Two	600 x 300	230
4050	2420	2 x 35W Twin Lamp	Two	700 x 300	2055	Two	700 x 300	235
4225	2420	2 x 35W Twin Lamp	Two	700 x 300	2055	Two	700 x 300	245
4400	2640	2 x 35W Twin Lamp	Two	700 x 300	2245	Two	700 x 300	250
4575	2640	2 x 35W Twin Lamp	Two	700 x 300	2245	Two	700 x 300	260
4800	2860	2 x 28W & 1 x 35W Twin Lamp	Three	600 x 300	2430	Three	600 x 300	285
4975	2860	2 x 28W & 1 x 35W Twin Lamp	Three	600 x 300	2430	Three	600 x 300	305
5150	3080	1 x 24W & 2 x 35W Twin Lamp	Three	600 x 300	2620	Three	600 x 300	305
5325	3080	1 x 28W & 2 x 35W Twin Lamp	Three	600 x 300	2620	Three	600 x 300	325
5500	3300	3 x 35W Twin Lamp	Three	600 x 300	2805	Three	600 x 300	320
5675	3300	3 x 35W Twin Lamp	Three	600 x 300	2805	Three	600 x 300	340
5850	3520	3 x 35W Twin Lamp	Three	700 x 300	2990	Three	700 x 300	335
6025	3520	3 x 35W Twin Lamp	Three	700 x 300	2990	Three	700 x 300	355
6200	3740	3 x 35W Twin Lamp	Three	700 x 300	3180	Three	700 x 300	355
6375	3740	3 x 35W Twin Lamp	Three	700 x 300	3180	Three	700 x 300	375
6550	3960	3 x 35W Twin Lamp	Three	800 x 300	3365	Three	800 x 300	370
6725	3960	3 x 35W Twin Lamp	Three	800 x 300	3365	Three	800 x 300	390

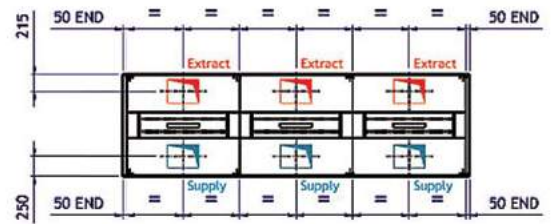
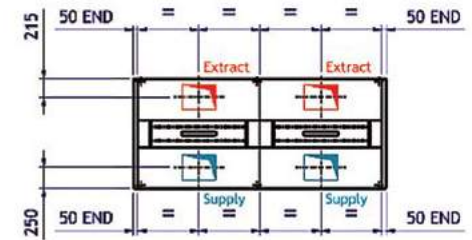
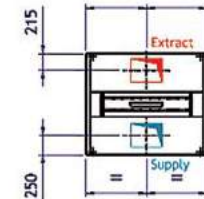

(1) Alternative dimensions / sizes are available upon request.  
 (2) Maximum Extract Volume base upon use of Superstream baffle type grease filter panels.

# Capturestream CS3R

## Wall and island hood configurations

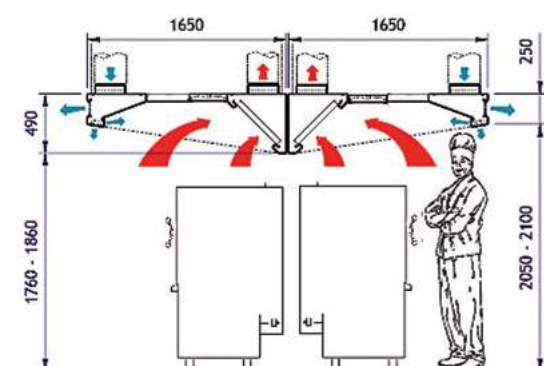
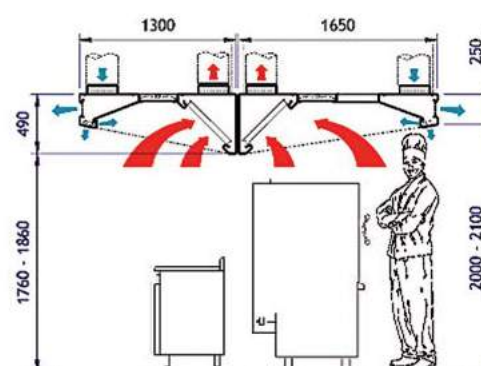
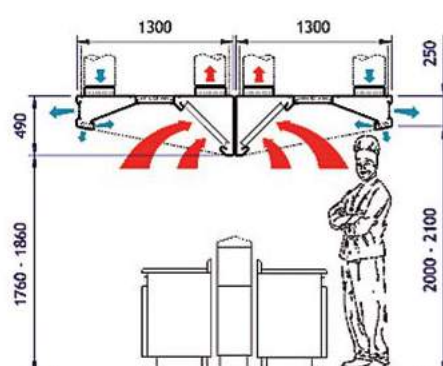
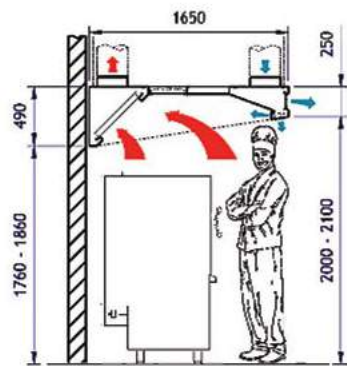
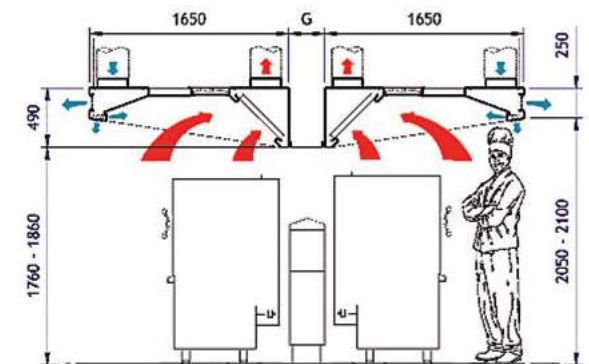
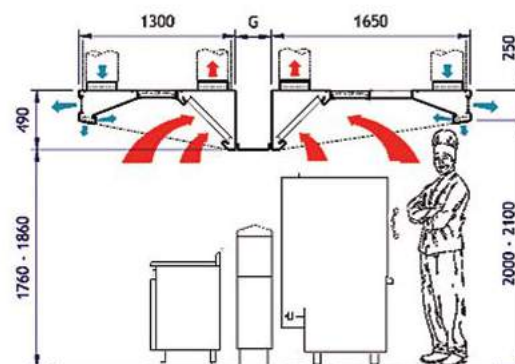
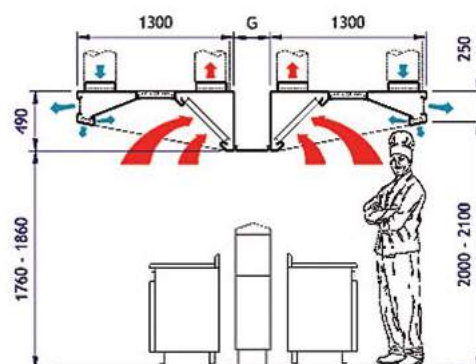
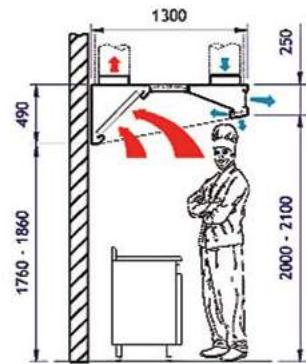

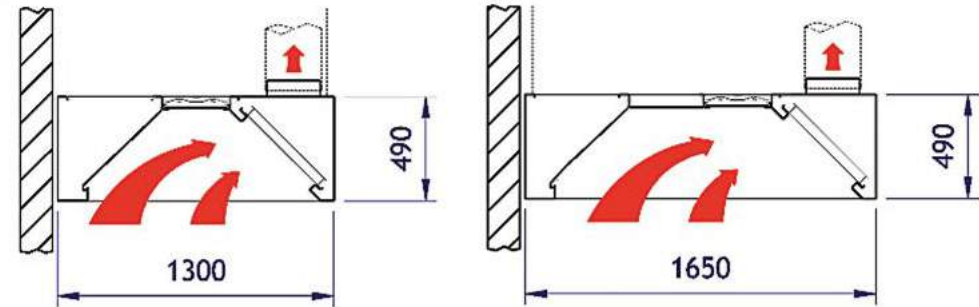

## Econex EF

Extract only - Front mounted

Length (mm)	Max. Extract Volume <sup>2</sup> (l/s)	Light Fittings	Extract Spigots <sup>1</sup> (Qty)	Extract Spigot Dimensions (mm)	Max. Supply Volume (l/s)	Supply Spigots <sup>1</sup> (Qty)	Supply Spigot Dimensions <sup>2</sup> (mm)	Weight (Kg)
1200	660	1 x 21W Twin Lamp	One	400 x 300	0	None	N/A	80
1375	660	1 x 21W Twin Lamp	One	400 x 300	0	None	N/A	90
1550	880	1 x 28W Twin Lamp	One	500 x 300	0	None	N/A	95
1725	880	1 x 28W Twin Lamp	One	500 x 300	0	None	N/A	105
1900	1100	1 x 35W Twin Lamp	One	600 x 300	0	None	N/A	110
2075	1100	1 x 35W Twin Lamp	One	600 x 300	0	None	N/A	120
2250	1320	1 x 35W Twin Lamp	One	800 x 300	0	None	N/A	125
2425	1320	1 x 35W Twin Lamp	One	800 x 300	0	None	N/A	135
2650	1540	1 x 21W & 1 x 28W Twin Lamp	Two	400 x 300	0	None	N/A	155
2825	1540	1 x 21W & 1 x 28W Twin Lamp	Two	400 x 300	0	None	N/A	165
3000	1760	2 x 28W Twin Lamp	Two	500 x 300	0	None	N/A	170
3175	1760	2 x 28W Twin Lamp	Two	500 x 300	0	None	N/A	180
3350	1980	1 x 28W & 1 x 35W Twin Lamp	Two	600 x 300	0	None	N/A	185
3525	1980	1 x 28W & 1 x 38W Twin Lamp	Two	600 x 300	0	None	N/A	195
3700	2200	2 x 35W Twin Lamp	Two	600 x 300	0	None	N/A	205
3875	2200	2 x 35W Twin Lamp	Two	600 x 300	0	None	N/A	215
4050	2420	2 x 35W Twin Lamp	Two	700 x 300	0	None	N/A	220
4225	2420	2 x 35W Twin Lamp	Two	700 x 300	0	None	N/A	230
4400	2640	2 x 35W Twin Lamp	Two	700 x 300	0	None	N/A	235
4575	2640	2 x 35W Twin Lamp	Two	700 x 300	0	None	N/A	245
4800	2860	2 x 28W & 1 x 35W Twin Lamp	Three	600 x 300	0	None	N/A	260
4975	2860	2 x 28W & 1 x 35W Twin Lamp	Three	600 x 300	0	None	N/A	280
5150	3080	1 x 24W & 2 x 35W Twin Lamp	Three	600 x 300	0	None	N/A	280
5325	3080	1 x 28W & 2 x 35W Twin Lamp	Three	600 x 300	0	None	N/A	300
5500	3300	3 x 35W Twin Lamp	Three	600 x 300	0	None	N/A	295
5675	3300	3 x 35W Twin Lamp	Three	600 x 300	0	None	N/A	315
5850	3520	3 x 35W Twin Lamp	Three	700 x 300	0	None	N/A	310
6025	3520	3 x 35W Twin Lamp	Three	700 x 300	0	None	N/A	330
6200	3740	3 x 35W Twin Lamp	Three	700 x 300	0	None	N/A	325
6375	3740	3 x 35W Twin Lamp	Three	700 x 300	0	None	N/A	345
6550	3960	3 x 35W Twin Lamp	Three	800 x 300	0	None	N/A	340
6725	3960	3 x 35W Twin Lamp	Three	800 x 300	0	None	N/A	360

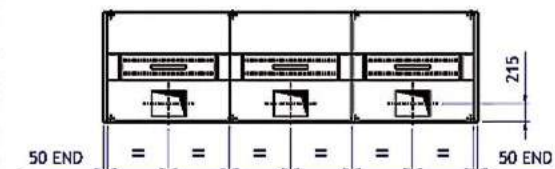
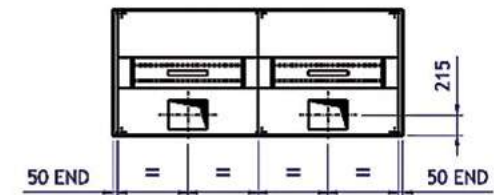
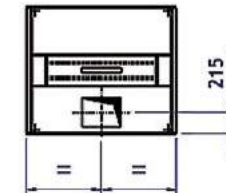

(1) Alternative dimensions / sizes are available upon request.

(2) Maximum Extract Volume base upon use of Superstream baffle type grease filter panels.

# Econex EF

## Wall and island hood configurations

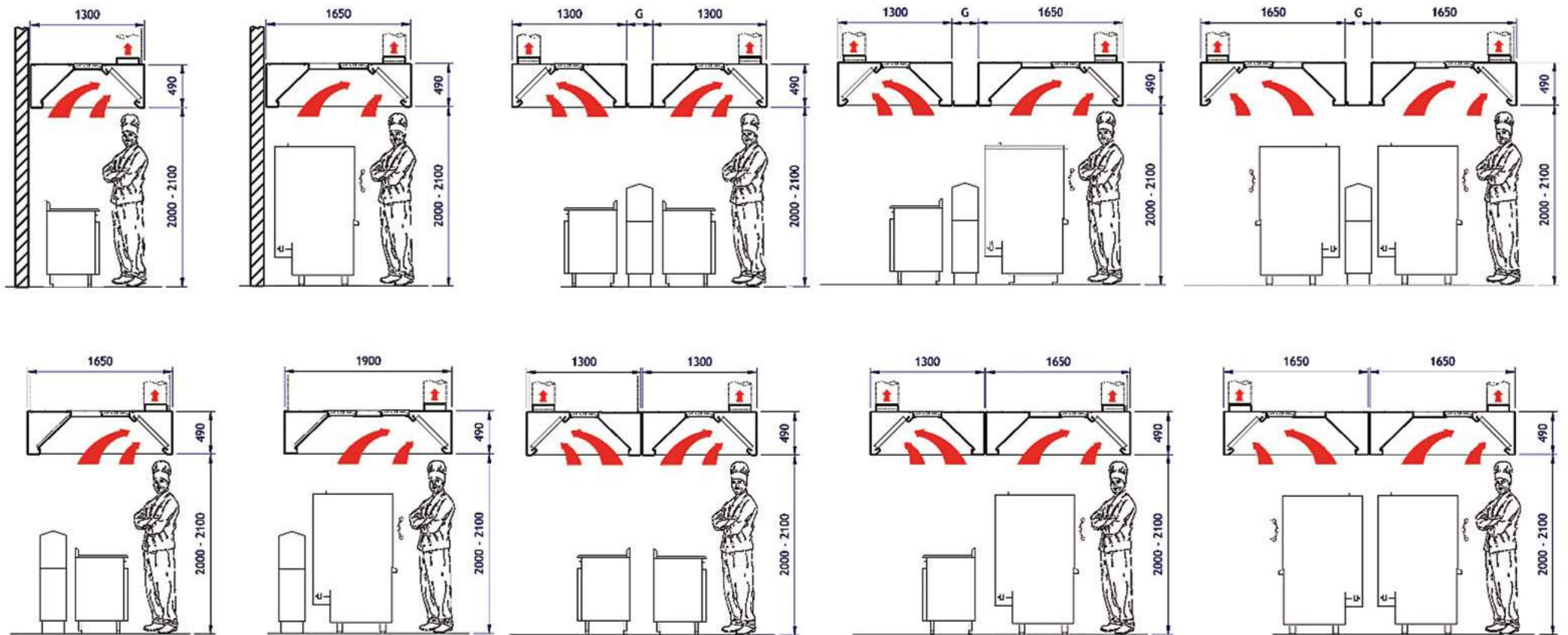



## Econex EFB

Extract only - Front & Back mounted

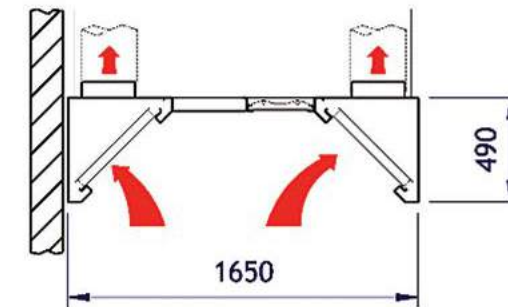
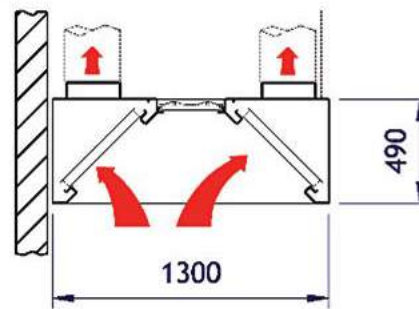

Length (mm)	Max. Extract Volume <sup>2</sup> (l/s)	Light Fittings	Extract Spigots <sup>1</sup> (Qty)	Extract Spigot Dimensions (mm)	Max. Supply Volume (l/s)	Supply Spigots <sup>1</sup> (Qty)	Supply Spigot Dimensions <sup>2</sup> (mm)	Weight (Kg)
1200	1320	1 x 21W Twin Lamp	One	400 x 300	0	None	N/A	90
1375	1320	1 x 21W Twin Lamp	One	400 x 300	0	None	N/A	100
1550	1760	1 x 28W Twin Lamp	One	500 x 300	0	None	N/A	110
1725	1760	1 x 28W Twin Lamp	One	500 x 300	0	None	N/A	120
1900	2200	1 x 35W Twin Lamp	One	600 x 300	0	None	N/A	130
2075	2200	1 x 35W Twin Lamp	One	600 x 300	0	None	N/A	140
2250	2640	1 x 35W Twin Lamp	One	800 x 300	0	None	N/A	145
2425	2640	1 x 35W Twin Lamp	One	800 x 300	0	None	N/A	155
2650	3080	1 x 21W & 1 x 28W Twin Lamp	Two	400 x 300	0	None	N/A	175
2825	3080	1 x 21W & 1 x 28W Twin Lamp	Two	400 x 300	0	None	N/A	185
3000	3520	2 x 28W Twin Lamp	Two	500 x 300	0	None	N/A	195
3175	3520	2 x 28W Twin Lamp	Two	500 x 300	0	None	N/A	205
3350	3960	1 x 28W & 1 x 35W Twin Lamp	Two	600 x 300	0	None	N/A	215
3525	3960	1 x 28W & 1 x 38W Twin Lamp	Two	600 x 300	0	None	N/A	225
3700	4400	2 x 35W Twin Lamp	Two	600 x 300	0	None	N/A	235
3875	4400	2 x 35W Twin Lamp	Two	600 x 300	0	None	N/A	245
4050	4840	2 x 35W Twin Lamp	Two	700 x 300	0	None	N/A	255
4225	4840	2 x 35W Twin Lamp	Two	700 x 300	0	None	N/A	265
4400	5280	2 x 35W Twin Lamp	Two	700 x 300	0	None	N/A	270
4575	5280	2 x 35W Twin Lamp	Two	700 x 300	0	None	N/A	280
4800	5720	2 x 28W & 1 x 35W Twin Lamp	Three	600 x 300	0	None	N/A	305
4975	5720	2 x 28W & 1 x 35W Twin Lamp	Three	600 x 300	0	None	N/A	325
5150	6160	1 x 24W & 2 x 35W Twin Lamp	Three	600 x 300	0	None	N/A	325
5325	6160	1 x 28W & 2 x 35W Twin Lamp	Three	600 x 300	0	None	N/A	345
5500	6600	3 x 35W Twin Lamp	Three	600 x 300	0	None	N/A	340
5675	6600	3 x 35W Twin Lamp	Three	600 x 300	0	None	N/A	360
5850	7040	3 x 35W Twin Lamp	Three	700 x 300	0	None	N/A	360
6025	7040	3 x 35W Twin Lamp	Three	700 x 300	0	None	N/A	380
6200	7480	3 x 35W Twin Lamp	Three	700 x 300	0	None	N/A	380
6375	7480	3 x 35W Twin Lamp	Three	700 x 300	0	None	N/A	400
6550	7920	3 x 35W Twin Lamp	Three	800 x 300	0	None	N/A	395
6725	7920	3 x 35W Twin Lamp	Three	800 x 300	0	None	N/A	415

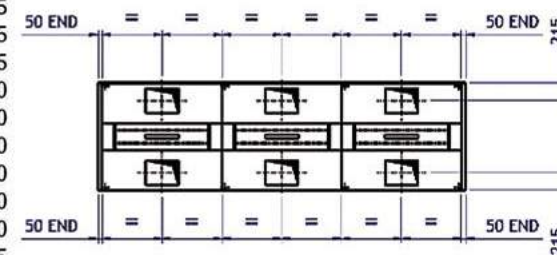
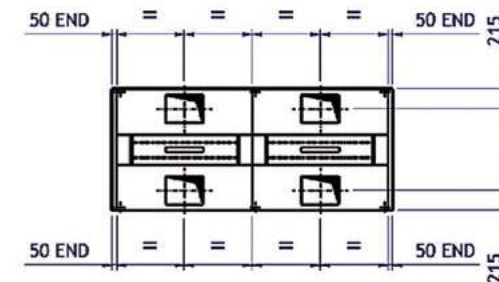
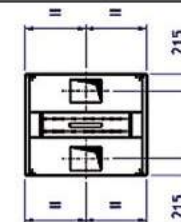

(1) Alternative dimensions / sizes are available upon request.

(2) Maximum Extract Volume base upon use of Superstream baffle type grease filter panels.



# Econex EFB

## Wall and island hood configurations

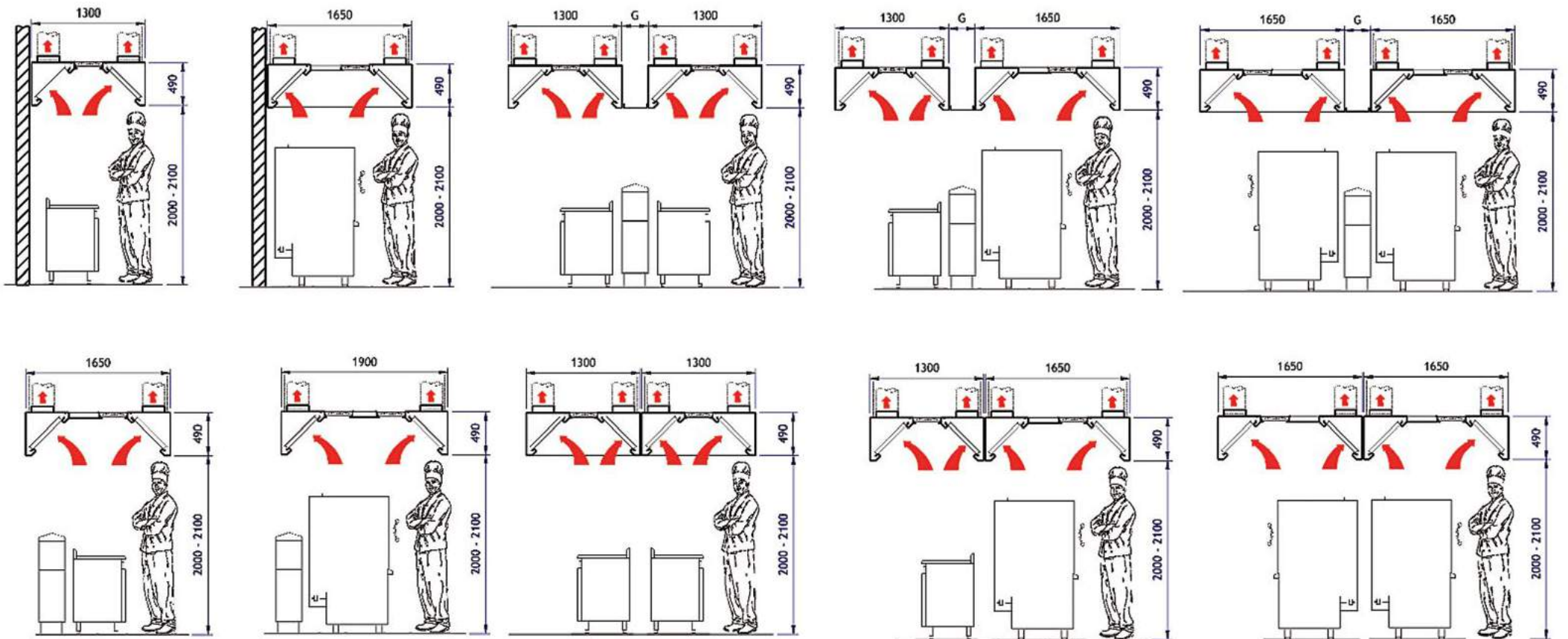

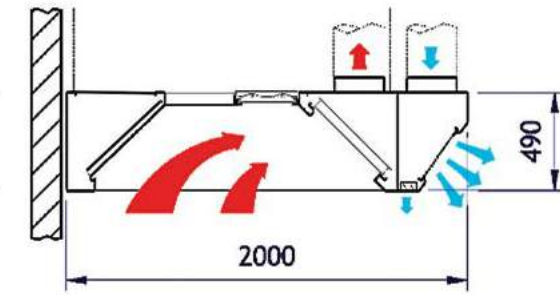
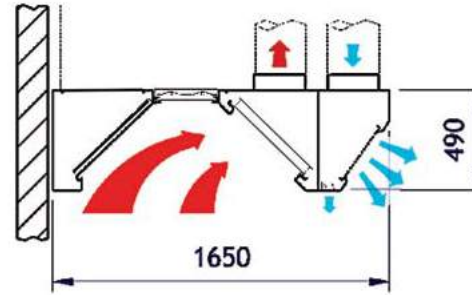

## Econex EFS2

Extract - Front mounted with front Supply & Spot cooling

Length (mm)	Max. Extract Volume <sup>2</sup> (l/s)	Light Fittings	Extract Spigots <sup>1</sup> (Qty)	Extract Spigot Dimensions (mm)	Max. Supply Volume (l/s)	Supply Spigots <sup>1</sup> (Qty)	Supply Spigot Dimensions* (mm)	Weight (Kg)
1200	660	1 x 21W Twin Lamp	One	400 x 300	560	One	400 x 300	95
1375	660	1 x 21W Twin Lamp	One	400 x 300	560	One	400 x 300	105
1550	880	1 x 28W Twin Lamp	One	500 x 300	750	One	500 x 300	115
1725	880	1 x 28W Twin Lamp	One	500 x 300	750	One	500 x 300	125
1900	1100	1 x 35W Twin Lamp	One	600 x 300	935	One	600 x 300	135
2075	1100	1 x 35W Twin Lamp	One	600 x 300	935	One	600 x 300	145
2250	1320	1 x 35W Twin Lamp	One	800 x 300	1120	One	800 x 300	150
2425	1320	1 x 35W Twin Lamp	One	800 x 300	1120	One	800 x 300	160
2650	1540	1 x 21W & 1 x 28W Twin Lamp	Two	400 x 300	1310	Two	400 x 300	185
2825	1540	1 x 21W & 1 x 28W Twin Lamp	Two	400 x 300	1310	Two	400 x 300	205
3000	1760	2 x 28W Twin Lamp	Two	500 x 300	1495	Two	500 x 300	205
3175	1760	2 x 28W Twin Lamp	Two	500 x 300	1495	Two	500 x 300	225
3350	1980	1 x 28W & 1 x 35W Twin Lamp	Two	600 x 300	1685	Two	600 x 300	225
3525	1980	1 x 28W & 1 x 38W Twin Lamp	Two	600 x 300	1685	Two	600 x 300	245
3700	2200	2 x 35W Twin Lamp	Two	600 x 300	1870	Two	600 x 300	245
3875	2200	2 x 35W Twin Lamp	Two	600 x 300	1870	Two	600 x 300	265
4050	2420	2 x 35W Twin Lamp	Two	700 x 300	2055	Two	700 x 300	265
4225	2420	2 x 35W Twin Lamp	Two	700 x 300	2055	Two	700 x 300	285
4400	2640	2 x 35W Twin Lamp	Two	700 x 300	2245	Two	700 x 300	280
4575	2640	2 x 35W Twin Lamp	Two	700 x 300	2245	Two	700 x 300	300
4800	2860	2 x 28W & 1 x 35W Twin Lamp	Three	600 x 300	2430	Three	600 x 300	315
4975	2860	2 x 28W & 1 x 35W Twin Lamp	Three	600 x 300	2430	Three	600 x 300	335
5150	3080	1 x 24W & 2 x 35W Twin Lamp	Three	600 x 300	2620	Three	600 x 300	335
5325	3080	1 x 28W & 2 x 35W Twin Lamp	Three	600 x 300	2620	Three	600 x 300	355
5500	3300	3 x 35W Twin Lamp	Three	600 x 300	2805	Three	600 x 300	355
5675	3300	3 x 35W Twin Lamp	Three	600 x 300	2805	Three	600 x 300	375
5850	3520	3 x 35W Twin Lamp	Three	700 x 300	2990	Three	700 x 300	375
6025	3520	3 x 35W Twin Lamp	Three	700 x 300	2990	Three	700 x 300	395
6200	3740	3 x 35W Twin Lamp	Three	700 x 300	3180	Three	700 x 300	395
6375	3740	3 x 35W Twin Lamp	Three	700 x 300	3180	Three	700 x 300	415
6550	3960	3 x 35W Twin Lamp	Three	800 x 300	3365	Three	800 x 300	410
6725	3960	3 x 35W Twin Lamp	Three	800 x 300	3365	Three	800 x 300	430

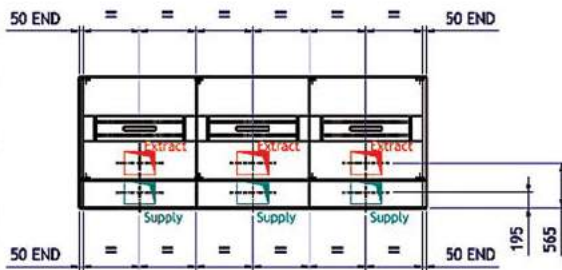
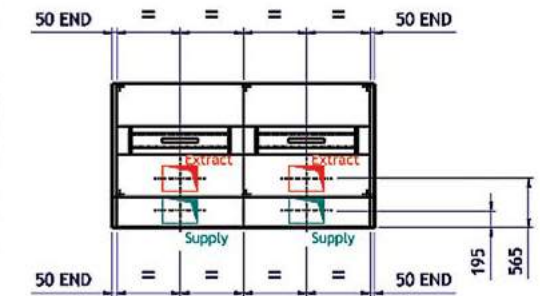
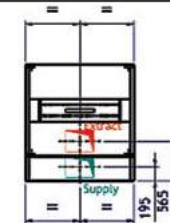

(1) Alternative dimensions / sizes are available upon request.

(2) Maximum Extract Volume base upon use of Superstream baffle type grease filter panels.

# Econex EFS2

## Wall and island hood configurations

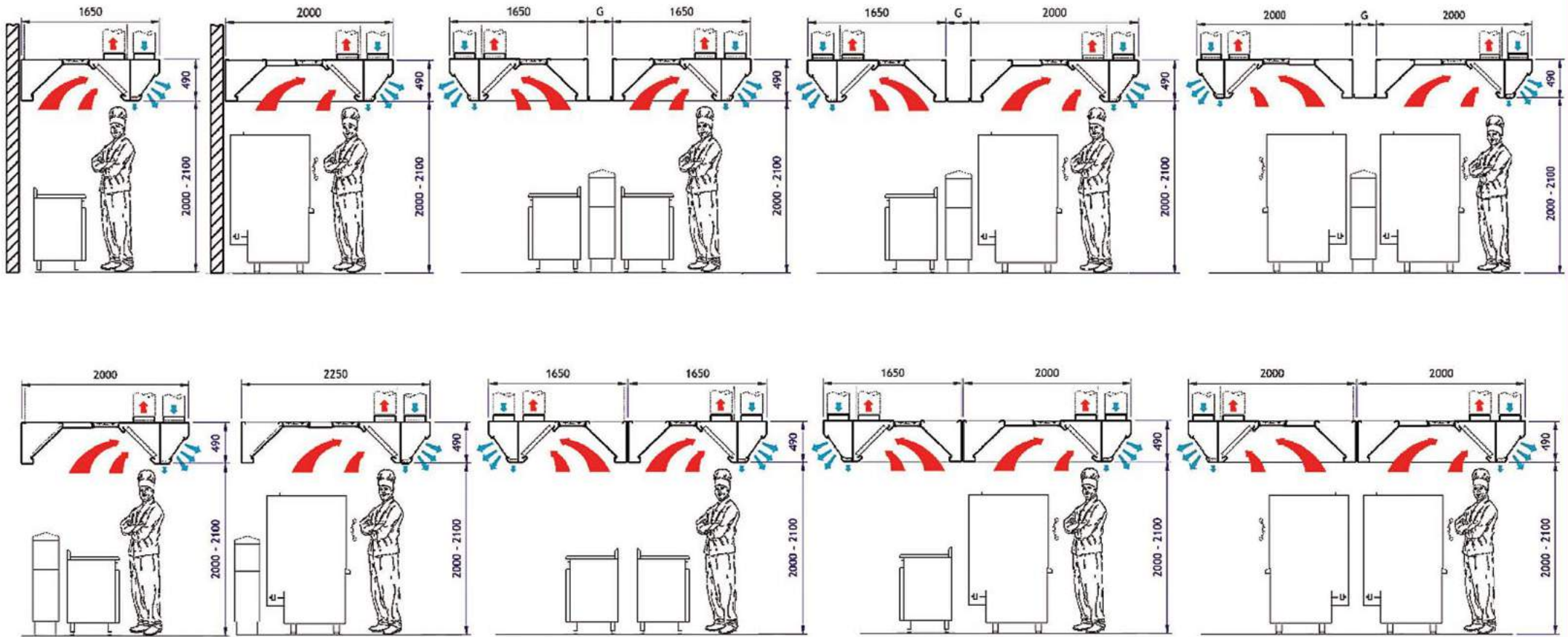

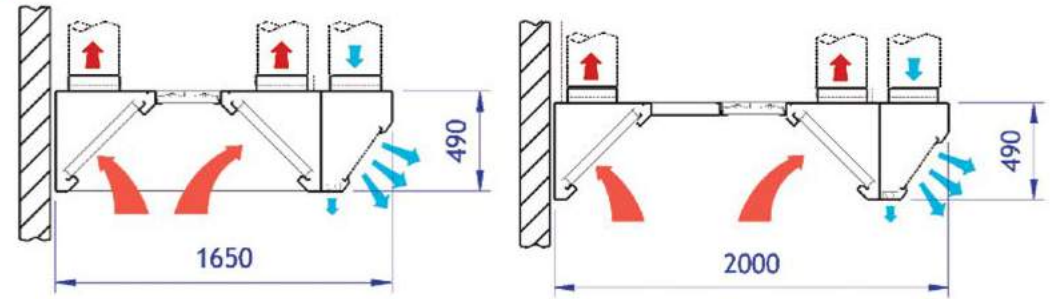
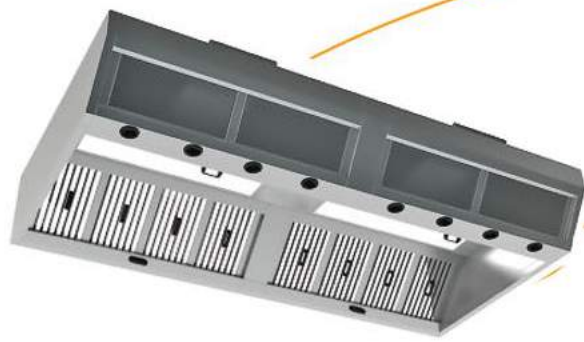

## Econex EFBS2

Extract - Front & Back mounted with front Supply & Spot cooling

Length (mm)	Max. Extract Volume <sup>2</sup> (l/s)	Light Fittings	Extract Spigots <sup>1</sup> (Qty)	Extract Spigot Dimensions (mm)	Max. Supply Volume (l/s)	Supply Spigots <sup>1</sup> (Qty)	Supply Spigot Dimensions* (mm)	Weight (Kg)
1200	1320	1 x 21W Twin Lamp	Two	400 x 300	560	One	400 x 300	105
1375	1320	1 x 21W Twin Lamp	Two	400 x 300	560	One	400 x 300	115
1550	1760	1 x 28W Twin Lamp	Two	500 x 300	750	One	500 x 300	125
1725	1760	1 x 28W Twin Lamp	Two	500 x 300	750	One	500 x 300	135
1900	2200	1 x 35W Twin Lamp	Two	600 x 300	935	One	600 x 300	150
2075	2200	1 x 35W Twin Lamp	Two	600 x 300	935	One	600 x 300	160
2250	2640	1 x 35W Twin Lamp	Two	800 x 300	1120	One	800 x 300	170
2425	2640	1 x 35W Twin Lamp	Two	800 x 300	1120	One	800 x 300	180
2650	3080	1 x 21W & 1 x 28W Twin Lamp	Four	400 x 300	1310	Two	400 x 300	210
2825	3080	1 x 21W & 1 x 28W Twin Lamp	Four	400 x 300	1310	Two	400 x 300	220
3000	3520	2 x 28W Twin Lamp	Four	500 x 300	1495	Two	500 x 300	230
3175	3520	2 x 28W Twin Lamp	Four	500 x 300	1495	Two	500 x 300	240
3350	3960	1 x 28W & 1 x 35W Twin Lamp	Four	600 x 300	1685	Two	600 x 300	255
3525	3960	1 x 28W & 1 x 38W Twin Lamp	Four	600 x 300	1685	Two	600 x 300	265
3700	4400	2 x 35W Twin Lamp	Four	600 x 300	1870	Two	600 x 300	275
3875	4400	2 x 35W Twin Lamp	Four	600 x 300	1870	Two	600 x 300	285
4050	4840	2 x 35W Twin Lamp	Four	700 x 300	2055	Two	700 x 300	300
4225	4840	2 x 35W Twin Lamp	Four	700 x 300	2055	Two	700 x 300	310
4400	5280	2 x 35W Twin Lamp	Four	700 x 300	2245	Two	700 x 300	320
4575	5280	2 x 35W Twin Lamp	Four	700 x 300	2245	Two	700 x 300	330
4800	5720	2 x 28W & 1 x 35W Twin Lamp	Six	600 x 300	2430	Three	600 x 300	360
4975	5720	2 x 28W & 1 x 35W Twin Lamp	Six	600 x 300	2430	Three	600 x 300	380
5150	6160	1 x 24W & 2 x 35W Twin Lamp	Six	600 x 300	2620	Three	600 x 300	380
5325	6160	1 x 28W & 2 x 35W Twin Lamp	Six	600 x 300	2620	Three	600 x 300	400
5500	6600	3 x 35W Twin Lamp	Six	600 x 300	2805	Three	600 x 300	405
5675	6600	3 x 35W Twin Lamp	Six	600 x 300	2805	Three	600 x 300	425
5850	7040	3 x 35W Twin Lamp	Six	700 x 300	2990	Three	700 x 300	425
6025	7040	3 x 35W Twin Lamp	Six	700 x 300	2990	Three	700 x 300	445
6200	7480	3 x 35W Twin Lamp	Six	700 x 300	3180	Three	700 x 300	445
6375	7480	3 x 35W Twin Lamp	Six	700 x 300	3180	Three	700 x 300	465
6550	7920	3 x 35W Twin Lamp	Six	800 x 300	3365	Three	800 x 300	470
6725	7920	3 x 35W Twin Lamp	Six	800 x 300	3365	Three	800 x 300	490

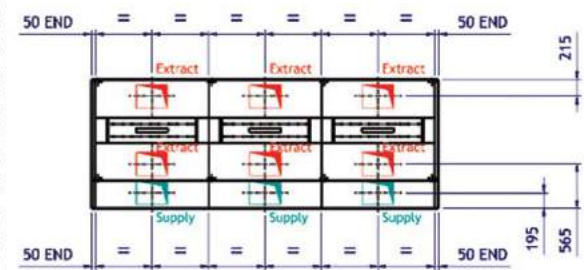
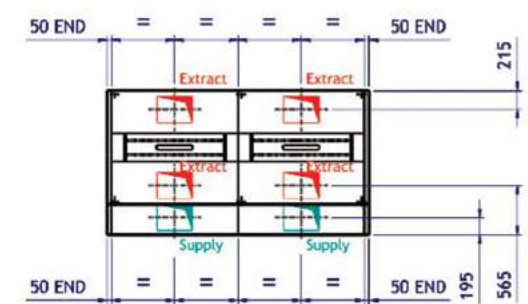
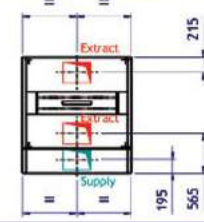

(1) Alternative dimensions / sizes are available upon request.

(2) Maximum Extract Volume base upon use of Superstream baffle type grease filter panels.

# Econex EFBS2

## Wall and island hood configurations

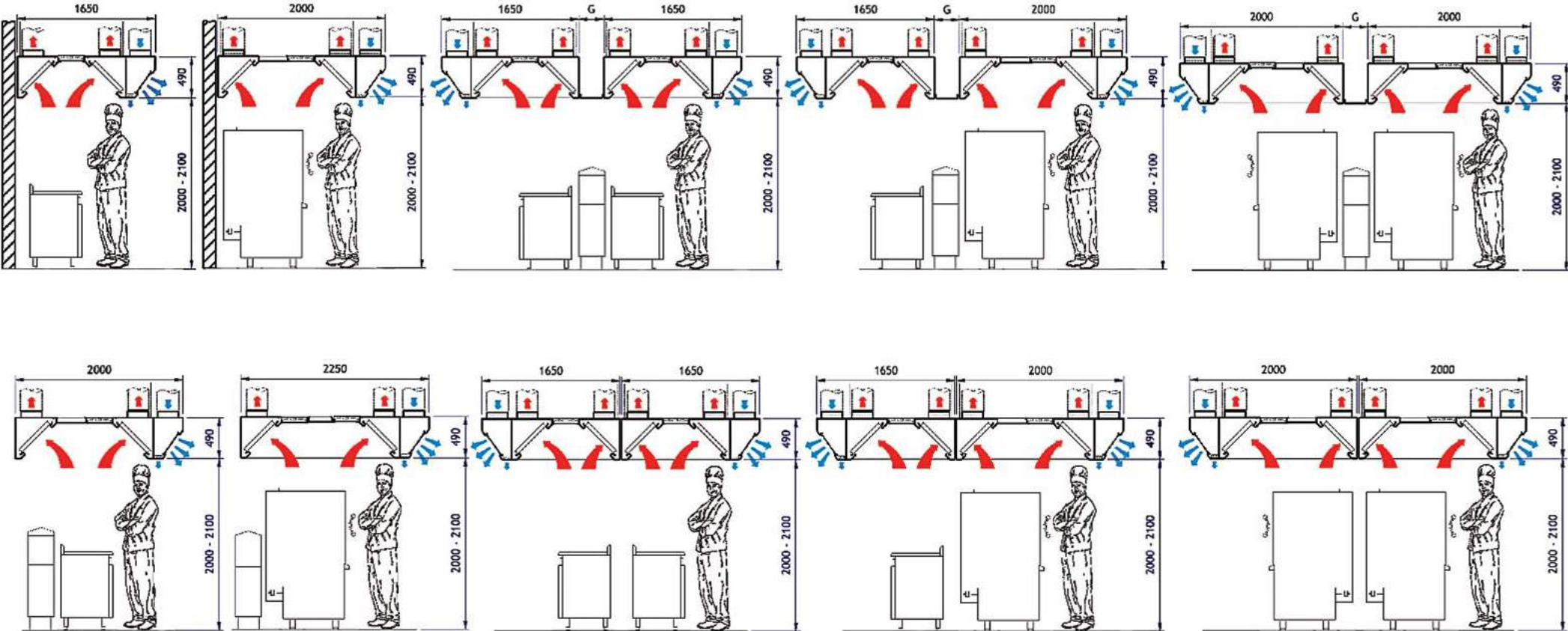



## Wash-up DWE

Extract only - standard depth

Length (mm)	Max. Extract Volume <sup>2</sup> (l/s)	Light Fittings	Extract Spigots <sup>1</sup> (Qty)	Extract Spigot Dimensions (mm)	Max. Supply Volume (l/s)	Supply Spigots <sup>1</sup> (Qty)	Supply Spigot Dimensions <sup>2</sup> (mm)	Weight (Kg)
1300	400	None	One	400 x 300	0	None	N/A	50
1800	400	None	One	400 x 300	0	None	N/A	70
2400	750	None	One	400 x 300	0	None	N/A	90

(1) Alternative dimensions / sizes are available upon request.

## Wash-up DWE

Wall and island hood configurations

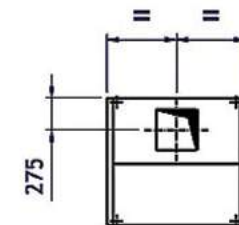
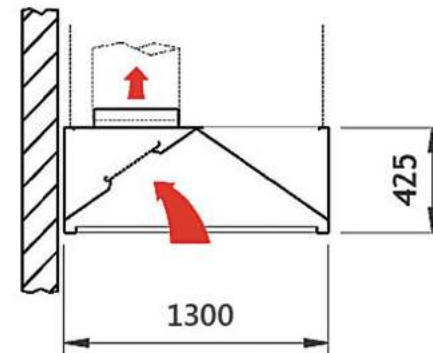
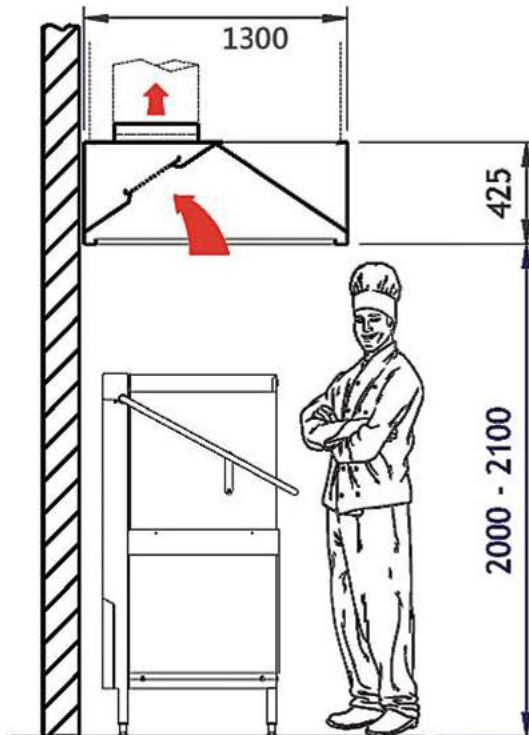

# Other Britannia Products

## Refresh



Refresh is a self contained kitchen ventilation unit that does not require ductwork ventilating to atmosphere. Ideal for use where ductwork is not easily installed, or where the fire risk must be contained to the kitchen compartment.



## Silverline



Silverline is based on shallow conventional extract canopies with the surrounding stainless steel ceiling being pressurised with supply air. Ideal for use over heavier duty cooking equipment. Silverline is a low maintenance option, and offers clean line-of-sight.



## UV Solutions

UV Solutions are available for most Britannia Canopies, and uniquely provide grease destruction and odour reduction without tedious tube cleaning required by other manufacturers.

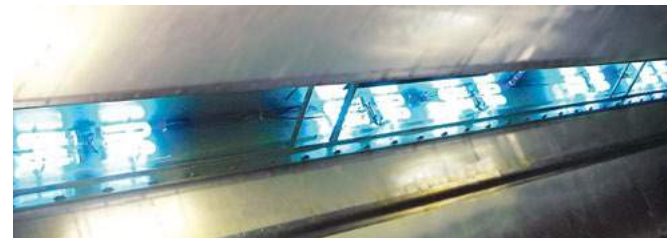

# Britannia

kitchen ventilation

Britannia's expertise and high performance exhaust canopies are now available and manufactured in Australia to the same high standards as they are famous for overseas.

For more information or site-specific specifications, call one of our friendly team or contact us via email or on-line.



## Telephone

03 8645 2555 VIC, SA, WA & TAS

02 9608 8620 NSW, QLD, NT



## Email

[sales@fsm-pl.com.au](mailto:sales@fsm-pl.com.au)



## Online

[www.britanniaaustralia.com.au](http://www.britanniaaustralia.com.au)



**FSM (FOOD SERVICE MACHINERY PTY. LTD.)**

HEAD OFFICE: UNIT E6, 63-85 TURNER STREET, PORT MELBOURNE, VIC. 3207 AUSTRALIA

T: +61 3 8645 2555 F: +61 3 8645 2565 E: [sales@fsm-pl.com.au](mailto:sales@fsm-pl.com.au) W: [www.fsm-pl.com.au](http://www.fsm-pl.com.au)

**SALES OFFICES IN NSW & QUEENSLAND. SALES AND SUPPORT THROUGHOUT AUSTRALIA**

As part of our continuous improvement policy, all specifications are subject to change without notice.

