

Bonn

HIGH PERFORMANCE SERIES MICROWAVE OVEN with **microSave**TM



**1400W
DUAL
MAGNETRONS**



The Bonn CM-1401T with 1400 Watts of cooking power output offers market leading speed. Heavy Duty construction, high power, 200 programs and Bonn's unique *MicroSave* protection makes the CM-1401T the most advanced Heavy Duty Commercial Microwave Oven.

The unique removable *MicroSave* cavity liner reduces service costs by up to 80% and extends the life of the oven and significantly improves hygiene by collecting all spills/spatters for easy cleaning. The patented *MicroSave* liner is available as an optional extra and is a must for all professional users.

The CM-1401T Oven utilises Dual Magnetron technology thus reducing the operating temperature of each magnetron by up to 50% when compared to single magnetron ovens - meaning a longer life span with greater reliability. This oven comes with an Industry Leading 3 year warranty**†

SPECIFICATIONS

Electrical: 240 V/ 50Hz, Single Phase 10amp plug
Current Draw: 9.9A
Microwave Power: 1400W
Number of Power levels: 4
Number of Programs: 200
Construction: Stainless Steel Interior and Exterior
Inner Door Construction: Toughened Glass
Outer Dimensions: (WxDxH) 464mm x 620mm x 368mm
Cavity Volume: 26L
Cavity Dimensions: (WxDxH) 370mm x 370mm x 190mm
Net Weight: 32kgs
Warranty: 36 Months* †

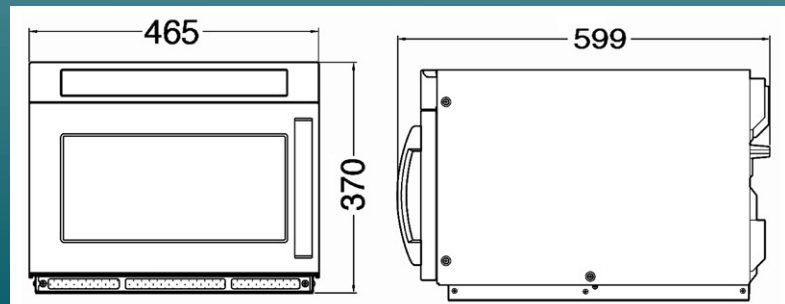

*† Full terms & conditions available from FSM P/L

FSM (FOOD SERVICE MACHINERY PTY. LTD.)

HEAD OFFICE:

21-23 Agosta Drive, Laverton North,
Vic. 3026 Australia
T: +61 3 9368 2300 F: +61 3 9369 3800
E: sales@fsm-pl.com.au W: www.fsm-pl.com.au

SYDNEY OFFICE:

Unit 15, 7-9 Progress Circuit,
Prestons, NSW 2170
T: +61 2 9608 8620 F: +61 2 9607 9370
E: sales@fsm-pl.com.au W: www.fsm-pl.com.au

QUEENSLAND OFFICE:

4/40 Rivergate Place,
Murarrie, QLD 4172
T: +61 7 3390 4185 F: +61 7 3393 9508
E: sales@fsm-pl.com.au W: www.fsm-pl.com.au

PERTH:

T: 0413 893 311
E: sales@fsm-pl.com.au
W: www.fsm-pl.com.au