



Project _____

Item # _____

Quantity _____

Hot/Cold Shelves Built-In Flush Top

Models:

HCSBFR-24-F, -24-I, -24-S, -36-F, -36-I, -36-S, -48-F,
-48-I, -48-S

HCSBFX-24-F, -24-I, -24-S, -36-F, -36-I, -36-S, -48-F,
-48-I, -48-S

Give your operation ultimate flexibility with Hatco's innovative, patented Hot/Cold Shelves Built-In Flush Top. Available in our signature Hardcoat, they easily transition between a heated to cold and cold to heated shelf!

The HCSBFR, HCSBFX Remote (R or X) models have the added benefit of offering design flexibility for fabricators.

Standard features

- The shelves change modes from hot to cold or vice versa in as little as 30 minutes, allowing quick change for different day parts
- HCSBFR units have unattached Condenser and Control Box
HCSBFX units have no Condenser (condenser supplied by others) and unattached Control Box
- HCSSBFR condensers utilize R-513A refrigerant and HCSSBFX models allow shelves to be cooled with other refrigerants
- Condensing unit features easy serviceability with sight glass, service valves, dryer/filter and receiver (HCSBFR models only)
- Patented thermal break reduces condensation and temperature transfer on adjacent surfaces
- All units have an Electronic Temperature Control Box with a 4' (1219 mm) lead wire (Standard)
- All models are hardcoat aluminum, top mount units
- All shelves match the GRSBF Heated Built-In Shelves for an integrated look
- Models shipped with shelf assembly with temperature probe, assembled TXV valve (shipped loose on HCSBFR, HCSBFX models), control box (shipped loose on HCSBFR, HCSBFX models), liquid line solenoid valve attached to shelf (HCSBFX models only) and HCSBFR models include condensing unit (shipped loose)
- All models not available with CE Mark

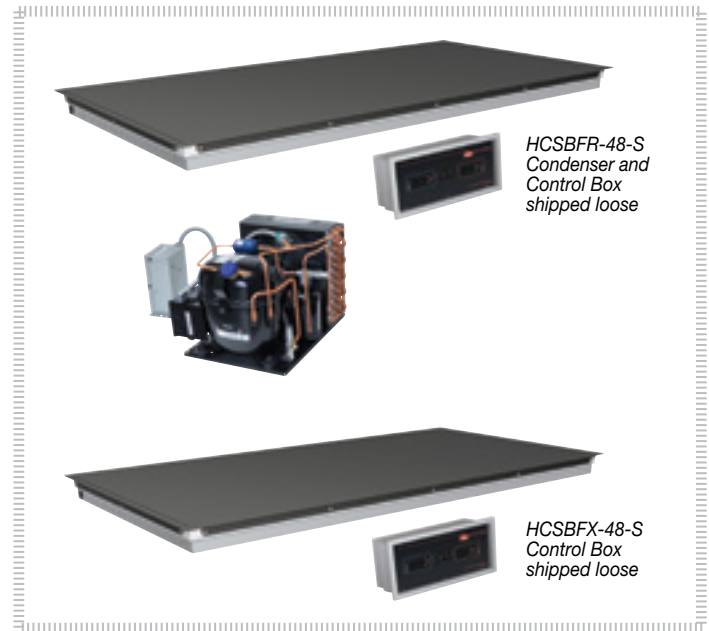

Options (available at time of purchase only)

- Additional four year parts only warranty on the compressor available at time of purchase (U.S. and Canada only)

NOTE: Install Remote Box outside Heat Zone or damage will occur.



Hot/Cold Shelves Built-In Flush Top

Models: HCSBFR-24-F, -24-I, -24-S, -36-F, -36-I, -36-S, -48-F, -48-I, -48-S
 HCSBFX-24-F, -24-I, -24-S, -36-F, -36-I, -36-S, -48-F, -48-I, -48-S

HCSBFR, HCSBFX

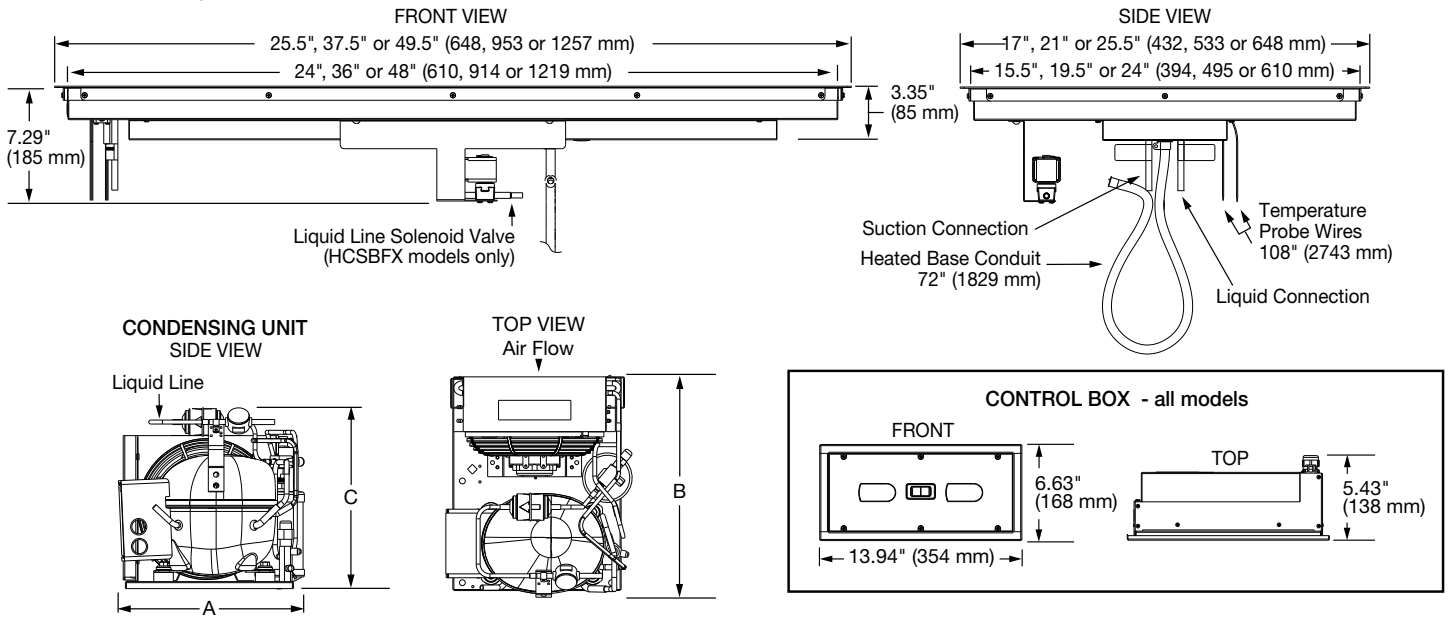

R-404A Condenser Dimensions for Built-In Flush Top Hot/Cold Shelves (For Export Markets Only)

Model	HZ	Voltages	Width (A)	Depth (B)	Height (C)
HCSBFR-24-F	60	120	11.80" (300 mm)	13.60" (346 mm)	11.40" (289 mm)
HCSBFX-24-F	50/60	220/230/240	12.10" (307 mm)	13.60" (346 mm)	11.40" (289 mm)
HCSBFR-24-I	60	120	11.80" (300 mm)	13.60" (346 mm)	11.40" (289 mm)
HCSBFX-24-I	50/60	220/230/240	12.10" (307 mm)	13.60" (346 mm)	11.40" (289 mm)
HCSBFR-24-S	60	120	11.80" (300 mm)	13.60" (346 mm)	11.40" (289 mm)
HCSBFX-24-S	50/60	220/230/240	12.10" (307 mm)	13.60" (346 mm)	11.40" (289 mm)
HCSBFR-36-F	60	120	11.80" (300 mm)	13.60" (346 mm)	11.40" (289 mm)
HCSBFX-36-F	50/60	220/230/240	12.10" (307 mm)	13.60" (346 mm)	11.40" (289 mm)
HCSBFR-36-I	60	120	11.90" (302 mm)	13.60" (346 mm)	11.40" (289 mm)
HCSBFX-36-I	50	220/230/240	13.10" (333 mm)	16" (406 mm)	11.70" (297 mm)
	60		12.10" (307 mm)	13.60" (346 mm)	11.40" (289 mm)
	60		11.90" (302 mm)	13.60" (346 mm)	11.40" (289 mm)
HCSBFR-36-S	60	120	11.90" (302 mm)	13.60" (346 mm)	11.40" (289 mm)
HCSBFX-36-S	50	220/230/240	13.10" (333 mm)	16" (406 mm)	11.70" (297 mm)
	60		12.10" (307 mm)	13.60" (346 mm)	11.40" (289 mm)
	60		11.90" (302 mm)	13.60" (346 mm)	11.40" (289 mm)
HCSBFR-48-F	60	120	11.90" (302 mm)	13.60" (346 mm)	11.40" (289 mm)
HCSBFX-48-F	50	220/230/240	13.10" (333 mm)	16" (406 mm)	11.70" (297 mm)
	60		12.10" (307 mm)	13.60" (346 mm)	11.40" (289 mm)
	60		11.90" (302 mm)	13.60" (346 mm)	11.40" (289 mm)
HCSBFR-48-I	60	120	11.90" (302 mm)	13.60" (346 mm)	11.40" (289 mm)
HCSBFX-48-I	50	220/230/240	13.10" (333 mm)	16" (406 mm)	11.70" (297 mm)
	60		12.10" (307 mm)	13.60" (346 mm)	11.40" (289 mm)
	60		13.10" (333 mm)	17.40" (442 mm)	11.80" (300 mm)
HCSBFR-48-S	60	120	13.10" (333 mm)	17.40" (442 mm)	11.80" (300 mm)
HCSBFX-48-S	50	220/230/240	12.10" (307 mm)	13.60" (346 mm)	11.40" (289 mm)
	60		14.34" (364 mm)	18" (457 mm)	11.80" (300 mm)
	60		12.10" (307 mm)	13.60" (346 mm)	11.40" (289 mm)



Hot/Cold Shelves Built-In Flush Top

Models: HCSBFR-24-F, -24-I, -24-S, -36-F, -36-I, -36-S, -48-F, -48-I, -48-S
 HCSBFX-24-F, -24-I, -24-S, -36-F, -36-I, -36-S, -48-F, -48-I, -48-S

SPECIFICATIONS

Hot/Cold Shelves Built-In Flush Top - Remote - R
 with unattached Condenser and Control Box

The shaded areas contain electrical information for International models

Model	Overall Shelf Dimensions W x D x H	Usable Shelf Space W x D of heated/cooled surface	Comp. Size HP	Volts ✓	Cold Side Watts	Hot Side Watts	Amps	Hz	Total Heat of Rejection (BTU/Hr)	Approx. Ship Weight
HCSBFR-24-F	25.5" x 17" x 7.29" (648 x 432 x 185 mm)	24" x 15.5" (610 x 394 mm)	1/5	120	300	355	3.8	60	1699	111 lbs. (51 kg)
			1/3	220	1089	325	5.0	50	2886	
				230	1190	355	5.2			
				240	1296	387	5.4			
			60	220	1129	325	5.1	60	2968	
				230	1234	355	5.4			
				240	1344	387	5.6			
HCSBFR-24-I	25.5" x 21" x 7.29" (648 x 533 x 185 mm)	24" x 19.5" (610 x 495 mm)	1/5	120	300	445	3.8	60	1839	118 lbs. (54 kg)
			1/3	220	1089	407	5.0	50	3026	
				230	1190	445	5.2			
				240	1296	485	5.4			
			60	220	1129	407	5.1	60	3108	
				230	1234	445	5.4			
				240	1344	485	5.6			
HCSBFR-24-S	25.5" x 25.5" x 7.29" (648 x 648 x 185 mm)	24" x 24" (610 x 610 mm)	1/5	120	300	550	4.6	60	1996	132 lbs. (60 kg)
			1/3	220	1089	503	5.0	50	3183	
				230	1190	550	5.2			
				240	1296	599	5.4			
			60	220	1129	503	5.1	60	3265	
				230	1234	550	5.4			
				240	1344	599	5.6			
HCSBFR-36-F	37.5" x 17" x 7.29" (953 x 432 x 185 mm)	36" x 15.5" (914 x 394 mm)	1/5	120	300	530	4.4	60	1970	147 lbs. (67 kg)
			1/3	220	1089	485	5.0	50	3157	
				230	1190	530	5.2			
				240	1296	577	5.4			
			60	220	1129	485	5.1	60	3239	
				230	1234	530	5.4			
				240	1344	577	5.6			
HCSBFR-36-I	37.5" x 21" x 7.29" (953 x 533 x 185 mm)	36" x 19.5" (914 x 495 mm)	1/3	120	450	670	5.9	60	2643	151 lbs. (69 kg)
			3/8	220	826	613	3.8	50	2787	
				230	904	670	3.9			
				240	984	730	4.1			
			60	220	1129	613	5.1	60	3401	
				230	1234	670	5.4			
				240	1344	730	5.6			
HCSBFR-36-S	37.5" x 25.5" x 7.29" (953 x 648 x 185 mm)	36" x 24" (914 x 610 mm)	1/3	120	450	825	6.9	60	2855	156 lbs. (71 kg)
			3/8	220	826	755	3.8	50	3064	
				230	904	825	3.9			
				240	984	898	4.1			
			60	220	1129	755	5.1	60	3612	
				230	1234	825	5.4			
				240	1344	898	5.6			
HCSBFR-48-F	49.5" x 17" x 7.29" (1257 x 432 x 185 mm)	48" x 15.5" (1219 x 394 mm)	1/3	120	450	710	5.9	60	2698	157 lbs. (72 kg)
			3/8	220	826	650	3.8	50	2842	
				230	904	710	3.9			
				240	984	773	4.1			
			60	220	1129	650	5.1	60	3456	
				230	1234	710	5.4			
				240	1344	773	5.6			
HCSBFR-48-I	49.5" x 21" x 7.29" (1257 x 533 x 185 mm)	48" x 19.5" (1219 x 495 mm)	1/3	120	450	890	7.4	60	3037	164 lbs. (75 kg)
			3/8	220	826	814	3.8	50	3306	
				230	904	890	3.9			
				240	984	969	4.1			
			60	220	1129	814	5.1	60	3707	
				230	1234	890	5.4			
				240	1344	969	5.6			
HCSBFR-48-S	49.5" x 25.5" x 7.29" (1257 x 648 x 185 mm)	48" x 24" (1219 x 610 mm)	5/8	120	800	1100	9.2	60	5137	196 lbs. (89 kg)
			1/2	220	826	1006	4.6	50	4088	
				230	904	1100	4.8			
				240	984	1198	5.6			
			60	220	1956	1006	8.9	60	6379	
				230	2138	1100	9.3			
				240	2328	1198	9.7			



Hot/Cold Shelves Built-In Flush Top

Models: HCSBFR-24-F, -24-I, -24-S, -36-F, -36-I, -36-S, -48-F, -48-I, -48-S
 HCSBFX-24-F, -24-I, -24-S, -36-F, -36-I, -36-S, -48-F, -48-I, -48-S

SPECIFICATIONS

Hot/Cold Shelves Built-In Flush Top - Remote - X
 with unattached Control Box only (no Condenser)

The shaded areas contain electrical information for International models

Model	Overall Shelf Dimensions W x D x H	Usable Space W x D	Volts ✓	Rated Watts	Rated Amps	Hz	Evaporator Load BTU/Hr	Approx. Ship Weight
HCSBFX-24-F	25.5" x 17" x 7.29" (648 x 432 x 185 mm)	24" x 15.5" (610 x 394 mm)	120	355	3.0	60	844	74 lbs. (34 kg)
			220	325	1.5	50	844	
			230	355	1.5			
			240	387	1.6			
			220	325	1.5	60	844	
			230	355	1.5			
240	387	1.6						
HCSBFX-24-I	25.5" x 21" x 7.29" (648 x 533 x 185 mm)	24" x 19.5" (610 x 495 mm)	120	445	3.7	60	1019	84 lbs. (39 kg)
			220	407	1.8	50	1019	
			230	445	1.9			
			240	485	2.0			
			220	407	1.8	60	1019	
			230	445	1.9			
240	485	2.0						
HCSBFX-24-S	25.5" x 25.5" x 7.29" (648 x 648 x 185 mm)	24" x 24" (610 x 610 mm)	120	550	4.6	60	1216	95 lbs. (44 kg)
			220	503	2.3	50	1216	
			230	550	2.4			
			240	599	2.5			
			220	503	2.3	60	1216	
			230	550	2.4			
240	599	2.5						
HCSBFX-36-F	37.5" x 17" x 7.29" (953 x 432 x 185 mm)	36" x 15.5" (914 x 394 mm)	120	530	4.4	60	1183	110 lbs. (50 kg)
			220	485	2.2	50	1183	
			230	530	2.3			
			240	577	2.4			
			220	485	2.2	60	1183	
			230	530	2.3			
240	577	2.4						
HCSBFX-36-I	37.5" x 21" x 7.29" (953 x 533 x 185 mm)	36" x 19.5" (914 x 495 mm)	120	670	5.6	60	1385	114 lbs. (52 kg)
			220	613	2.8	50	1385	
			230	670	2.9			
			240	730	3.0			
			220	613	2.8	60	1385	
			230	670	2.9			
240	730	3.0						
HCSBFX-36-S	37.5" x 25.5" x 7.29" (953 x 648 x 185 mm)	36" x 24" (914 x 610 mm)	120	825	6.9	60	1649	119 lbs. (54 kg)
			220	755	3.4	50	1649	
			230	825	3.5			
			240	898	3.7			
			220	755	3.4	60	1649	
			230	825	3.5			
240	898	3.7						
HCSBFX-48-F	49.5" x 17" x 7.29" (1257 x 432 x 185 mm)	48" x 15.5" (1219 x 394 mm)	120	710	5.9	60	1453	120 lbs. (55 kg)
			220	650	3.0	50	1453	
			230	710	3.1			
			240	773	3.2			
			220	650	3.0	60	1453	
			230	710	3.1			
240	773	3.2						
HCSBFX-48-I	49.5" x 21" x 7.29" (1257 x 533 x 185 mm)	48" x 19.5" (1219 x 495 mm)	120	890	7.4	60	1767	127 lbs. (58 kg)
			220	814	3.7	50	1767	
			230	890	3.9			
			240	969	4.0			
			220	814	3.7	60	1767	
			230	890	3.9			
240	969	4.0						
HCSBFX-48-S	49.5" x 25.5" x 7.29" (1257 x 648 x 185 mm)	48" x 24" (1219 x 610 mm)	120	1100	9.2	60	3009	149 lbs. (67 kg)
			220	1006	4.6	50	3009	
			230	1100	4.8			
			240	1198	5.0			
			220	1006	4.6	60	3009	
			230	1100	4.8			
240	1198	5.0						



Hot/Cold Shelves Built-In Flush Top

Models: HCSBFR-24-F, -24-I, -24-S, -36-F, -36-I, -36-S, -48-F, -48-I, -48-S
HCSBFX-24-F, -24-I, -24-S, -36-F, -36-I, -36-S, -48-F, -48-I, -48-S

PLUG CONFIGURATION

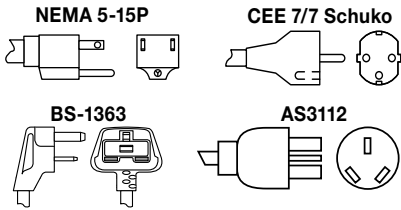

R-513A REFRIGERANT OPERATING SPECIFICATIONS IN 75°F (24°C) AMBIENT



Refer to the Installation section in the Installation and Operating Manual on the Hatco website

- Suction Pressure: 6-9 PSIG (0.4-0.6 Bar)
- Discharge Pressure : 115-125 PSIG (7.9-8.6 Bar)
- Superheat: 4-10° F (2.2 to 5.6°C)
- Subcooling: 5-10° F (2.8 to 5.6°C)

FACTORY FILL RATES for R-513A REFRIGERANT (HCSBFR condensers are shipped without refrigerants)

Model	Fill Weight	Model	Fill Weight
HCSBF-24-F	1 lb. 3 oz. (0.539 kg)	HCSBFR-24-F	1 lb. 13 oz. (0.822 kg)
HCSBF-24-I		HCSBFR-24-I	
HCSBF-24-S	1 lb. 5 oz. (0.595 kg)	HCSBFR-24-S	1 lb. 15 oz. (0.879 kg)
HCSBF-36-F	1 lb. 5 oz. (0.595 kg)	HCSBFR-36-F	1 lb. 15 oz. (0.879 kg)
HCSBF-36-I	1 lb. 3 oz. (0.539 kg)	HCSBFR-36-I	1 lb. 13 oz. (0.822 kg)
HCSBF-36-S		HCSBFR-36-S	
HCSBF-48-F	1 lb. 3 oz. (0.539 kg)	HCSBFR-48-F	1 lb. 13 oz. (0.822 kg)
HCSBF-48-I		HCSBFR-48-I	
HCSBF-48-S	1 lb. 15 oz. (0.879 kg)	HCSBFR-48-S	2 lb. 8 oz. (1.134 kg)

COUNTERTOP CUTOUT SIZE



See Installation and Operating Manuals for more information

Model	Width		Depth	
	Minimum	Maximum	Minimum	Maximum
HCSBFR-24-F HCSBFX-24-F	24.6" (625 mm)	25.0" (635 mm)	16.1" (409 mm)	16.5" (419 mm)
HCSBFR-24-I HCSBFX-24-I	24.6" (625 mm)	25.0" (635 mm)	20.1" (511 mm)	20.5" (521 mm)
HCSBFR-24-S HCSBFX-24-S	24.6" (625 mm)	25.0" (635 mm)	24.6" (625 mm)	25.0" (635 mm)
HCSBFR-36-F HCSBFX-36-F	36.6" (930 mm)	37.0" (940 mm)	16.1" (409 mm)	16.5" (419 mm)
HCSBFR-36-I HCSBFX-36-I	36.6" (930 mm)	37.0" (940 mm)	20.1" (511 mm)	20.5" (521 mm)
HCSBFR-36-S HCSBFX-36-S	36.6" (930 mm)	37.0" (940 mm)	24.6" (625 mm)	25.0" (635 mm)
HCSBFR-48-F HCSBFX-48-F	48.6" (1234 mm)	49.0" (1245 mm)	16.1" (409 mm)	16.5" (419 mm)
HCSBFR-48-I HCSBFX-48-I	48.6" (1234 mm)	49.0" (1245 mm)	20.1" (511 mm)	20.5" (521 mm)
HCSBFR-48-S HCSBFX-48-S	48.6" (1234 mm)	49.0" (1245 mm)	24.6" (625 mm)	25.0" (635 mm)
All Models	Width		Height	
Control Box Cut Out Dimensions	13.125" (333 mm)		5.625" (143 mm)	