

TOP VIEW

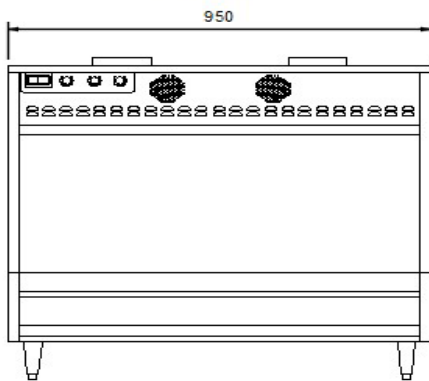

SIDE VIEW

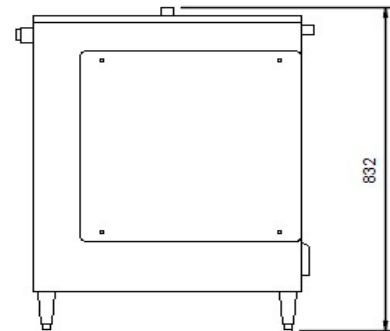

FRONT VIEW

**Glo-Ray Multi-Product Warming Station**

the ultimate in hot fried food holding with six thermostatically controlled high power overhead ceramic heating elements and base element complemented by food grade teflon coated incandescent lamps for enhanced product display.

**STANDARD FEATURES**

- Standard side panel that attaches on right or left side
- Available as a freestanding model in two widths
- Easy access to food product
- Base heat is adjusted using a thermostatic control
- Six overhead ceramic heating elements are adjusted by two separate electronic controls one for the rear elements and one for the front elements
- Coated shatter-resistant incandescent bulbs
- All stainless steel construction
- Master On/Off rocker switch
- Shipped with 102 mm adjustable legs
- Unit comes with a 1829 mm cord and plug, and a right/left side pane

**SPECIFICATION**

Dimensions	950W x 630D x 832H mm
Weight	79Kgs
Output Power	3075 Watts
Power Source	13.4 amp. supplied with corded 15amp plug.