



Project _____

Item # _____

Quantity _____

Remote Hot/Cold Built-In Flush Top Simulated Stone Shelves

Models:

HCSSBFR-24-F, -24-I, -24-S, -36-F, -36-I, -36-S, -48-F, -48-I, -48-S

HCSSBFX-24-F, -24-I, -24-S, -36-F, -36-I, -36-S, -48-F, -48-I, -48-S

Give your operation ultimate flexibility with Hatco's innovative, patented Remote Hot/Cold Built-In Flush Top Simulated Stone Shelves. They easily transition between a heated to cold and cold to heated shelf! These shelves are available in three attractive Swanstone® colors.

The HCSSBFR and HCSSBFX models have the added benefit of offering design flexibility for fabricators.

Standard features

- Shelves change modes from hot to cold or vice versa in as little as 30 minutes, allowing quick change for different day parts
- HCSSBFR units have unattached Condenser and Control Box; HCSSBFX units have no Condenser (condenser supplied by others) and unattached Control Box
- HCSSBFR condensers utilize R-513A refrigerant; HCSSBFX models allow shelves to be cooled with other refrigerants
- Condensing unit features easy serviceability with sight glass, service valves, dryer/filter and receiver (HCSSBFR models only)
- All units have an Electronic Temperature Control Box with a 4' (1219 mm) lead wire (Standard)
- All units are bottom mount, flush with counter top
- Patented thermal break reduces condensation and temperature transfer on adjacent surfaces
- Models shipped with shelf assembly with temperature probe, assembled TXV valve (shipped loose on HCSSBFR, HCSSBFX models), control box (shipped loose on HCSSBFR, HCSSBFX models), liquid line solenoid valve attached to shelf (HCSSBFX models only) and HCSSBFR models include condensing unit (shipped loose)
- All models not available with CE Mark
- Models with simulated stone finishes are Swanstone®



Options (available at time of purchase only)

Simulated Stone Finishes – Swanstone – Ash Gray standard –
 Non-standard colors are non-returnable
 Birch Ice

Additional four year parts only warranty on the compressor available at time of purchase (U.S. and Canada only)

NOTE: Install Remote Box outside Heat Zone or damage will occur.



Remote Hot/Cold Built-In Flush Top Simulated Stone Shelves

Models: HCSSBFR-24-F, -24-I, -24-S, -36-F, -36-I, -36-S, -48-F, -48-I, -48-S
 HCSSBFX-24-F, -24-I, -24-S, -36-F, -36-I, -36-S, -48-F, -48-I, -48-S

HCSSBFR, HCSSBFX

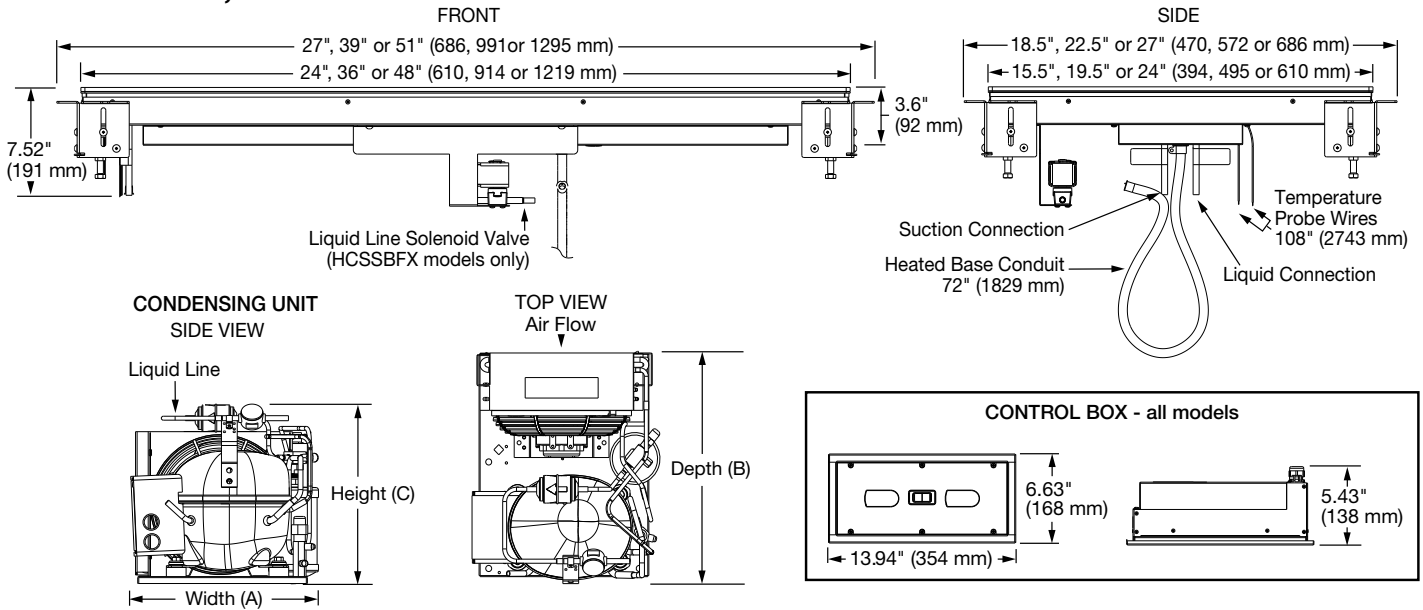

R-404A Condenser Dimensions for Hot/Cold Simulated Stone Shelves Built-In Flush Top (For Export Markets Only)

Model	HZ	Voltages	Width (A)	Depth (B)	Height (C)
HCSSBFR-24-F	60	120	11.80" (300 mm)	13.60" (346 mm)	11.40" (289 mm)
	50/60	220/230/240	12.10" (307 mm)	13.60" (346 mm)	11.40" (289 mm)
HCSSBFR-24-I	60	120	11.80" (300 mm)	13.60" (346 mm)	11.40" (289 mm)
	50/60	220/230/240	12.10" (307 mm)	13.60" (346 mm)	11.40" (289 mm)
HCSSBFR-24-S	60	120	11.80" (300 mm)	13.60" (346 mm)	11.40" (289 mm)
	50/60	220/230/240	12.10" (307 mm)	13.60" (346 mm)	11.40" (289 mm)
HCSSBFR-36-F	60	120	11.80" (300 mm)	13.60" (346 mm)	11.40" (289 mm)
	50/60	220/230/240	12.10" (307 mm)	13.60" (346 mm)	11.40" (289 mm)
HCSSBFR-36-I	60	120	11.90" (302 mm)	13.60" (346 mm)	11.40" (289 mm)
	50	220/230/240	13.10" (333 mm)	16" (406 mm)	11.70" (297 mm)
	60		12.10" (307 mm)	13.60" (346 mm)	11.40" (289 mm)
HCSSBFR-36-S	60	120	11.90" (302 mm)	13.60" (346 mm)	11.40" (289 mm)
	50	220/230/240	13.10" (333 mm)	16" (406 mm)	11.70" (297 mm)
	60		12.10" (307 mm)	13.60" (346 mm)	11.40" (289 mm)
HCSSBFR-48-F	60	120	11.90" (302 mm)	13.60" (346 mm)	11.40" (289 mm)
	50	220/230/240	13.10" (333 mm)	16" (406 mm)	11.70" (297 mm)
	60		12.10" (307 mm)	13.60" (346 mm)	11.40" (289 mm)
HCSSBFR-48-I	60	120	11.90" (302 mm)	13.60" (346 mm)	11.40" (289 mm)
	50	220/230/240	13.10" (333 mm)	16" (406 mm)	11.70" (297 mm)
	60		12.10" (307 mm)	13.60" (346 mm)	11.40" (289 mm)
HCSSBFR-48-S	60	120	13.10" (333 mm)	17.40" (442 mm)	11.80" (300 mm)
	50	220/230/240	12.10" (307 mm)	13.60" (346 mm)	11.40" (289 mm)
	60		14.34" (364 mm)	18" (457 mm)	11.80" (300 mm)



Remote Hot/Cold Built-In Flush Top Simulated Stone Shelves

Models: HCSSBFR-24-F, -24-I, -24-S, -36-F, -36-I, -36-S, -48-F, -48-I, -48-S
HCSSBFX-24-F, -24-I, -24-S, -36-F, -36-I, -36-S, -48-F, -48-I, -48-S

SPECIFICATIONS

Remote Hot/Cold Built-In Flush Top Simulated Stone Shelves - With unattached Condenser and Control Box

The shaded areas contain electrical information for International models

Model	Overall Shelf Dimensions W x D x H	Usable Space W x D of heated/cooled surface	Comp. Size HP	Volts [✓]	Cold Side Watts	Hot Side Watts	Amps	Hz	Approx. Ship Weight	
HCSSBFR-24-F	27" x 18.5" x 7.52" (686 x 470 x 191 mm)	24" x 15.5" (610 x 394 mm)	1/5	120	300	355	3.8	60	107 lbs. (49 kg)	
			1/3	220	1089	325	5.0	50		
				230	1190	355	5.2			
				240	1296	387	5.4			
				220	1129	325	5.1			60
				230	1234	355	5.4			
240	1344	387	5.6							
HCSSBFR-24-I	27" x 22.5" x 7.52" (686 x 572 x 191 mm)	24" x 19.5" (610 x 495 mm)	1/5	120	300	445	3.8	60	123 lbs. (56 kg)	
			1/3	220	1089	407	5.0	50		
				230	1190	445	5.2			
				240	1296	485	5.4			
				220	1129	407	5.1			60
				230	1234	445	5.4			
240	1344	485	5.6							
HCSSBFR-24-S	27" x 27" x 7.52" (686 x 686 x 191 mm)	24" x 24" (610 x 610 mm)	1/5	120	300	550	4.6	60	142 lbs. (65 kg)	
			1/3	220	1089	503	5.0	50		
				230	1190	550	5.2			
				240	1296	599	5.4			
				220	1129	503	5.1			60
				230	1234	550	5.4			
240	1344	599	5.6							
HCSSBFR-36-F	39" x 18.5" x 7.52" (991 x 470 x 191 mm)	36" x 15.5" (914 x 394 mm)	1/5	120	300	530	4.4	60	138 lbs. (63 kg)	
			1/3	220	1089	485	5.0	50		
				230	1190	530	5.2			
				240	1296	577	5.4			
				220	1129	485	5.1			60
				230	1234	530	5.4			
240	1344	577	5.6							
HCSSBFR-36-I	39" x 22.5" x 7.52" (991 x 572 x 191 mm)	36" x 19.5" (914 x 495 mm)	1/3	120	450	670	5.9	60	159 lbs. (73 kg)	
			3/8	220	826	613	3.8	50		
				230	904	670	3.9			
				240	984	730	4.1			
			1/3	220	1129	613	5.1	60		
				230	1234	670	5.4			
240	1344	730		5.6						
HCSSBFR-36-S	39" x 27" x 7.52" (991 x 686 x 191 mm)	36" x 24" (914 x 610 mm)	1/3	120	450	825	6.9	60	190 lbs. (87 kg)	
			3/8	220	826	755	3.8	50		
				230	904	825	3.9			
				240	984	898	4.1			
			1/3	220	1129	755	5.1	60		
				230	1234	825	5.4			
240	1344	898		5.6						
HCSSBFR-48-F	51" x 18.5" x 7.52" (1295 x 470 x 191 mm)	48" x 15.5" (1219 x 394 mm)	1/3	120	450	710	5.9	60	167 lbs. (76 kg)	
			3/8	220	826	650	3.8	50		
				230	904	710	3.9			
				240	984	773	4.1			
			1/3	220	1129	650	5.1	60		
				230	1234	710	5.4			
240	1344	773		5.6						
HCSSBFR-48-I	51" x 22.5" x 7.52" (1295 x 572 x 191 mm)	48" x 19.5" (1219 x 495 mm)	1/3	120	450	890	7.4	60	206 lbs. (94 kg)	
			3/8	220	826	814	3.8	50		
				230	904	890	3.9			
				240	984	969	4.1			
			1/3	220	1129	814	5.1	60		
				230	1234	890	5.4			
240	1344	969		5.6						
HCSSBFR-48-S	51" x 27" x 7.52" (1295 x 686 x 191 mm)	48" x 24" (1219 x 610 mm)	5/8	120	800	1100	9.2	60	212 lbs. (97 kg)	
			1/2	220	826	1006	4.6	50		
				230	904	1100	4.8			
				240	984	1198	5.6			
			5/8	220	1956	1006	8.9	60		
				230	2138	1100	9.3			
240	2328	1198		9.7						



Remote Hot/Cold Built-In Flush Top Simulated Stone Shelves

Models: HCSSBFR-24-F, -24-I, -24-S, -36-F, -36-I, -36-S, -48-F, -48-I, -48-S
HCSSBFX-24-F, -24-I, -24-S, -36-F, -36-I, -36-S, -48-F, -48-I, -48-S

SPECIFICATIONS

Remote Hot/Cold Built-In Flush Top Simulated Stone Shelves -
With unattached Control Box only (no Condenser)

The shaded areas contain electrical
information for International models

Model	Overall Shelf Dimensions W x D x H	Usable Shelf Space W x D	Volts	Rated Watts	Rated Amps	Hz	Evaporator Load BTU/Hr	Approx. Ship Weight
HCSSBFX-24-F	27" x 18.5" x 7.52" (686 x 394 x 191 mm)	24" x 15.5" (610 x 394 mm)	120	355	3.0	60	844	70 lbs. (49 kg)
			220	325	1.5	50	844	
			230	355	1.5			
			240	387	1.6			
			220	325	1.5	60	844	
			230	355	1.5			
240	387	1.6						
HCSSBFX-24-I	27" x 22.5" x 7.52" (686 x 495 x 191 mm)	24" x 19.5" (610 x 495 mm)	120	445	3.7	60	1019	86 lbs. (40 kg)
			220	407	1.8	50	1019	
			230	445	1.9			
			240	485	2.0			
			220	407	1.8	60	1019	
			230	445	1.9			
240	485	2.0						
HCSSBFX-24-S	27" x 27" x 7.52" (686 x 610 x 191 mm)	24" x 24" (610 x 610 mm)	120	550	4.6	60	1216	105 lbs. (48 kg)
			220	503	2.3	50	1216	
			230	550	2.4			
			240	599	2.5			
			220	503	2.3	60	1216	
			230	550	2.4			
240	599	2.5						
HCSSBFX-36-F	39" x 18.5" x 7.52" (991 x 394 x 191 mm)	36" x 15.5" (914 x 394 mm)	120	530	4.4	60	1183	101 lbs. (46 kg)
			220	485	2.2	50	1183	
			230	530	2.3			
			240	577	2.4			
			220	485	2.2	60	1183	
			230	530	2.3			
240	577	2.4						
HCSSBFX-36-I	39" x 19.5" x 7.52" (991 x 495 x 191 mm)	36" x 19.5" (914 x 495 mm)	120	670	5.6	60	1385	122 lbs. (56 kg)
			220	613	2.8	50	1385	
			230	670	2.9			
			240	730	3.0			
			220	613	2.8	60	1385	
			230	670	2.9			
240	730	3.0						
HCSSBFX-36-S	39" x 27" x 7.52" (991 x 610 x 191 mm)	36" x 24" (914 x 610 mm)	120	825	6.9	60	1649	153 lbs. (62 kg)
			220	755	3.4	50	1649	
			230	825	3.5			
			240	898	3.7			
			220	755	3.4	60	1649	
			230	825	3.5			
240	898	3.7						
HCSSBFX-48-F	51" x 18.5" x 7.52" (1295 x 470 x 191 mm)	48" x 15.5" (1219 x 394 mm)	120	710	5.9	60	1453	130 lbs. (59 kg)
			220	650	3.0	50	1453	
			230	710	3.1			
			240	773	3.2			
			220	650	3.0	60	1453	
			230	710	3.1			
240	773	3.2						
HCSSBFX-48-I	51" x 22.5" x 7.52" (1295 x 572 x 191 mm)	48" x 19.5" (1219 x 495 mm)	120	890	7.4	60	1767	169 lbs. (77 kg)
			220	814	3.7	50	1767	
			230	890	3.9			
			240	969	4.0			
			220	814	3.7	60	1767	
			230	890	3.9			
240	969	4.0						
HCSSBFX-48-S	51" x 27" x 7.52" (1295 x 686 x 191 mm)	48" x 24" (1219 x 610 mm)	120	1100	9.2	60	3009	165 lbs. (75 kg)
			220	1006	4.6	50	3009	
			230	1100	4.8			
			240	1198	5.0			
			220	1006	4.6	60	3009	
			230	1100	4.8			
240	1198	5.0						

⚡ All voltages non-CE



Remote Hot/Cold Built-In Flush Top Simulated Stone Shelves

Models: HCSSBFR-24-F, -24-I, -24-S, -36-F, -36-I, -36-S, -48-F, -48-I, -48-S
HCSSBFX-24-F, -24-I, -24-S, -36-F, -36-I, -36-S, -48-F, -48-I, -48-S

R-513A REFRIGERANT OPERATING SPECIFICATIONS IN 75°F (24°C) AMBIENT

HCSSBF, HCSSBFX models only.



Refer to the Installation section in the Installation and Operating Manual on the [Hatco website](#)

- Suction Pressure: 6-9 PSIG (0.4-0.6 Bar)
- Discharge Pressure : 115-125 PSIG (7.9-8.6 Bar)
- Superheat: 4-10° F (2.2 to 5.6°C)
- Subcooling: 5-10° F (2.8 to 5.6°C)

FACTORY FILL RATES for R-513A REFRIGERANT

Model	Fill Weight
HCSSBFR-24-F	1 lb. 13 oz. (0.822 kg)
HCSSBFR-24-I	
HCSSBFR-24-S	1 lb. 15 oz. (0.879 kg)
HCSSBFR-36-F	1 lb. 15 oz. (0.879 kg)
HCSSBFR-36-I	1 lb. 13 oz. (0.822 kg)
HCSSBFR-36-S	
HCSSBFR-48-F	1 lb. 13 oz. (0.822 kg)
HCSSBFR-48-I	
HCSSBFR-48-S	2 lb. 8 oz. (1.134 kg)

COUNTERTOP CUTOUT SIZE



See [Installation and Operating Manuals](#) for more information

Model	Width	Depth
	with .375" (10 mm) radii	with .375" (10 mm) radii
HCSSBFR-24-F	24.375"	15.875"
HCSSBFX-24-F	619 mm)	(403 mm)
HCSSBFR-24-I	24.375"	19.875"
HCSSBFX-24-I	(619 mm)	(505 mm)
HCSSBFR-24-S	24.375"	24.375"
HCSSBFX-24-S	(619 mm)	(619 mm)
HCSSBFR-36-F	36.375"	15.875"
HCSSBFX-36-F	(924 mm)	(403 mm)
HCSSBFR-36-I	36.375"	19.875"
HCSSBFX-36-I	924 mm)	(505 mm)
HCSSBFR-36-S	36.375"	24.375"
HCSSBFX-36-S	(924 mm)	(619 mm)
HCSSBFR-48-F	48.375"	15.875"
HCSSBFX-48-F	(1229 mm)	(403 mm)
HCSSBFR-48-I	48.375"	19.875"
HCSSBFX-48-I	(1229 mm)	(505 mm)
HCSSBFR-48-S	48.375"	24.375"
HCSSBFX-48-S	1229 mm)	(619 mm)
All Models	Width	Height
Control Box	13.125"	5.625"
Cut Out Dimensions	(333 mm)	143 mm)