

DROP IN ICE CREAM FREEZER

The Silver King Drop in Ice Cream Freezer is easily installed in any bar or bench top. Complete with stainless steel interior with covered corners for fast, easy cleaning.

There is an anti-condensation heater around the top opening to prevent moisture formation.

Insulated with environmentally friendly polyurethane foamed-in-place for maximum efficiency, strength and durability.



SKDI FEATURES INCLUDE

- Refrigeration system is CFC-free, hermetically sealed, and self contained with fan cooled condenser.
- Cold wall evaporator provides optimum ice cream dipping temperature.
- Comes with adjustable electronic temperature control.
- Drop in Model features heavy gauge, galvanised steel welded angle frame and base assembly.

Due to our policy of continual product development and improvement, all details and specification are subject to change without notice.

FSM (FOOD SERVICE MACHINERY PTY. LTD.)

HEAD OFFICE:

21-23 Agosta Drive, Laverton North,
Vic. 3026 Australia
T: +61 3 9368 2300 F: +61 3 9369 3800
E: sales@fsm-pl.com.au W: www.fsm-pl.com.au

SYDNEY OFFICE:

Unit 15, 7-9 Progress Circuit,
Prestons, NSW 2170
T: +61 2 9608 8620 F: +61 2 9607 9370
E: sales@fsm-pl.com.au W: www.fsm-pl.com.au

QUEENSLAND OFFICE:

4/40 Rivergate Place,
Murarrie, QLD 4172
T: +61 7 3390 4185 F: +61 7 3393 9508
E: sales@fsm-pl.com.au W: www.fsm-pl.com.au

PERTH:

T: 0413 893 311
E: sales@fsm-pl.com.au
W: www.fsm-pl.com.au

SPECIFICATIONS

TOP VIEW

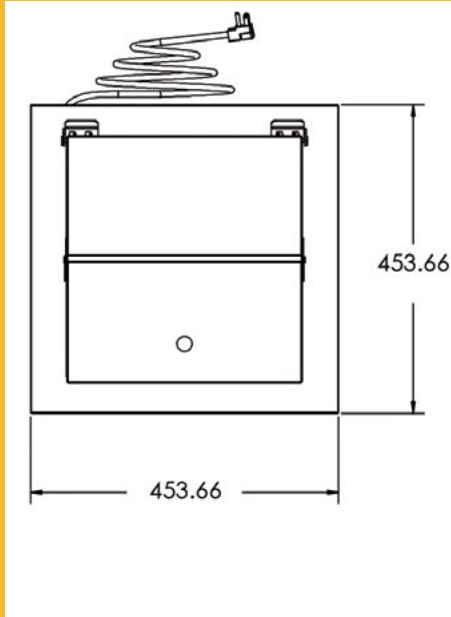

FRONT VIEW

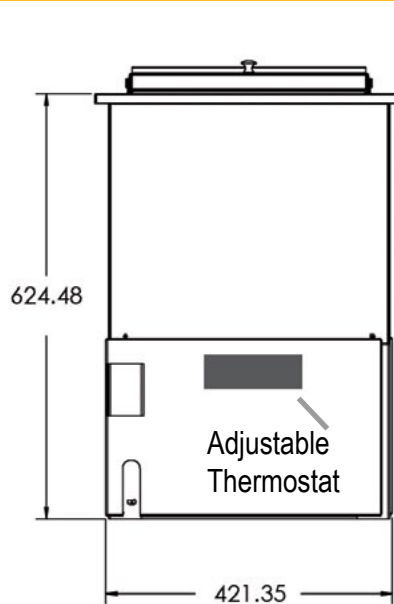

SIDE VIEW

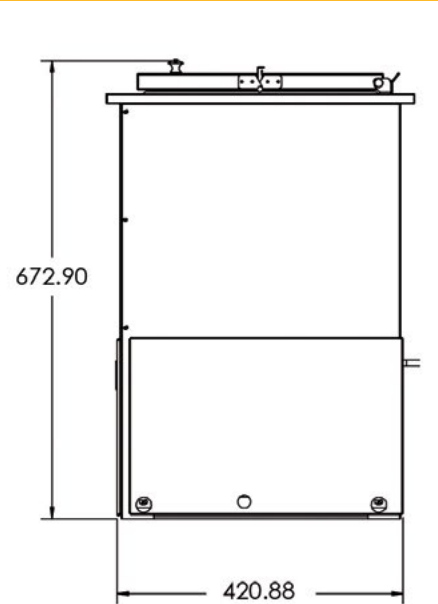

SPECIFICATION

CFC-free R134 refrigerant self contained with fan cooled condenser.
 Cold wall evaporator provides optimum ice cream dipping temperature.
 Adjustable electronic control that has a temp range of -4.40°C to -12°C.
 Heavy gauge, galvanised steel welded angle frame and base assembly.

Power: 240V 480W, 2A supplied with 10 amp plug.

DIMENSIONS: (less lid): 625mmH X 413 mmW X 413mm D

Weight: 36Kgs

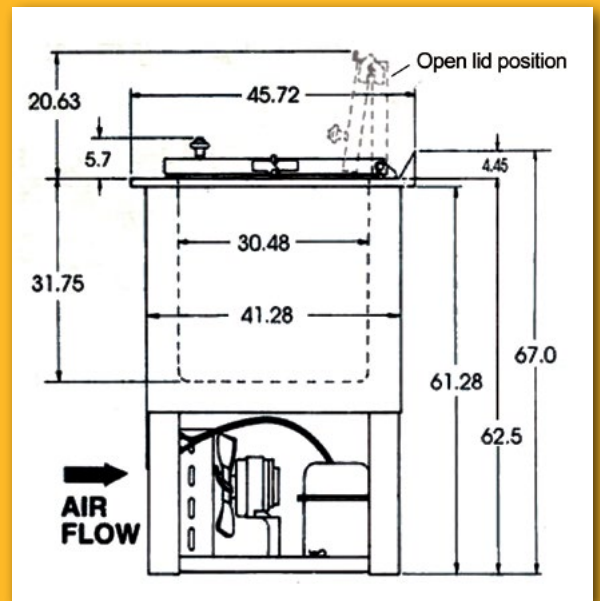

Due to our policy of continual product development and improvement, all details and specification are subject to change without notice.

HEAD OFFICE:

SYDNEY OFFICE:

QUEENSLAND OFFICE:

PERTH: