

TOP VIEW

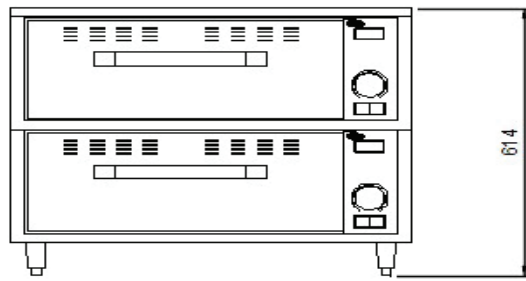

FRONT VIEW

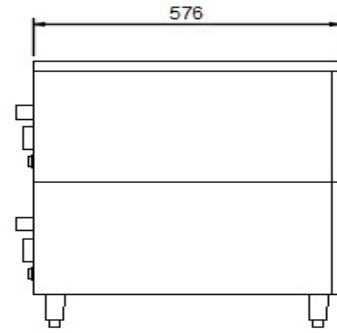

SIDE VIEW

Hold everything from meat, to vegetables, to rolls in the **Hatco Drawer Warmer**. Each Drawer features adjustable sliding vents and individual thermostatic controls to hold a wide variety of hot foods safely for peak serving periods.

SPECIFICATION

Dimensions	749W x 576D x 614Hmm
Weight	74Kgs
Output Power	9.84Kw
Power Source	Supplied with 10amp plug.

STANDARD FEATURES

- Independant temperature control and ON/OFF powerswitch on each drawer
- Heavy-duty construction with durable drawer frame and slides
- Includes two full-size stainless steel 150 mm food pans
- Adjustable vents control moisture on each drawer
- Angled chrome handle deflects cart traffic
- Easy to clean, black powdercoated exterior