



## GLO-MAX<sup>®</sup> Curved Display Lights

Models | HLC5-30/-36/-42/-48/-54/-66/-78

A stylish choice for illuminating your serving area. The HLC5 LED Display Light offers the highest light output that is ideal for illuminating food products with a cool white light (4000K).

The sleek, curved design is patented and the LED lighting delivers significant savings with lower energy consumption and greater reliability.



### Features:

- Features a patented curved housing design that has energy efficient dual LED lights across the display lamp that provide longer performance and energy savings (compared to standard incandescent bulbs)
- Matches the Hatco line of GLO-MAX<sup>®</sup> Curved Infrared Strip Heaters for a fully integrated look
- 7 lengths are available: 762, 915, 1067, 1219, 1372, 1677, 1982 mm

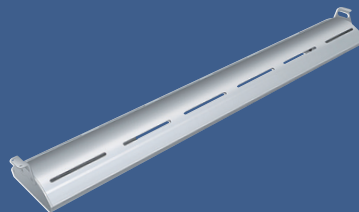

HLC5-48, with angle brackets included

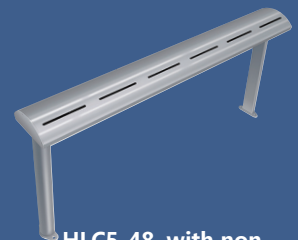

HLC5-48, with non-adjustable tubular stands (not included)

# GLO-MAX<sup>®</sup> Curved Display Lights



## Angle Bracket

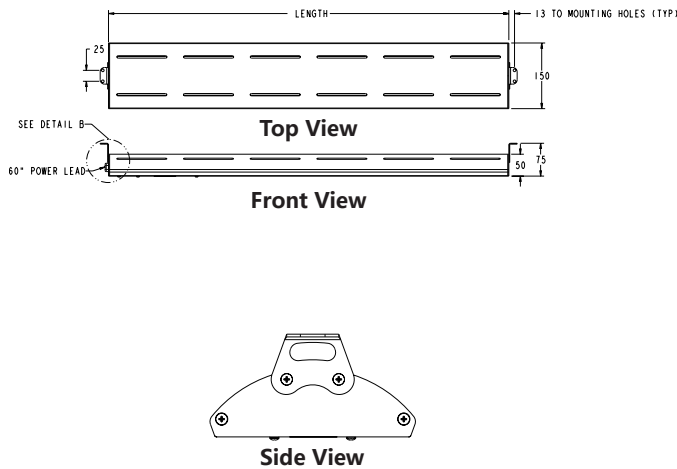

## Non-Adjustable Tubular Stands

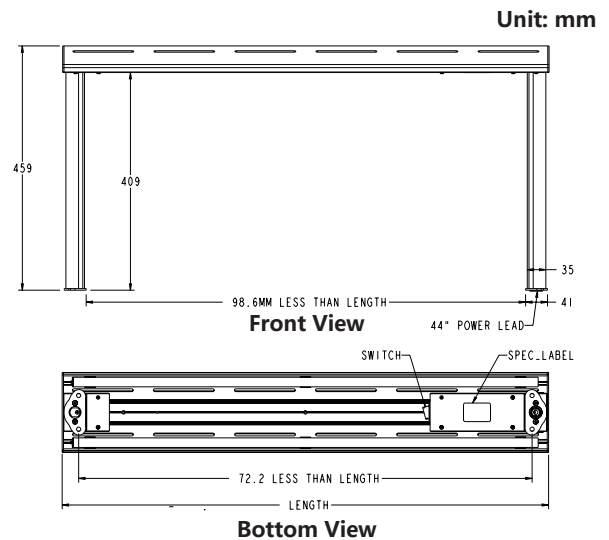

MODEL	VOLTAGE(V)	POWER(W)	CURRENT(A)	SHIP WEIGHT(kg)	DIMENSIONS(W x D x H)
HLC5-30	220~240	11	0.05	4kg (9 lbs.)	762 x 150 x 50 mm
HLC5-36		14	0.06	4kg (9 lbs.)	915 x 150 x 50 mm
HLC5-42		15~16	0.07	5kg (11 lbs.)	1067 x 150 x 50 mm
HLC5-48		17	0.08	6kg (12 lbs.)	1219 x 150 x 50 mm
HLC5-54		19	0.08	7kg (16 lbs.)	1372 x 150 x 50 mm
HLC5-66		22	0.09~0.1	8kg (18 lbs.)	1677 x 150 x 50 mm
HLC5-78		24	0.1~0.11	8kg (18 lbs.)	1982 x 150 x 50 mm

- Housing colour: standard clear anodized or optional black anodised
- LED light colour: cool white (4000K)
- Mounting options: standard angle brackets or optional 406 mm non-adjustable tubular stands
- Rocker Switch, location: under unit on power side
- Power wire lead length: 1524 mm
- CE certification