



Excellence since 1976

**CATALOGUE / PRICE LIST
NEW ZEALAND**

EFFECTIVE: APRIL 2022

OFFICE AND WAREHOUSE IN AUCKLAND
SERVICE ACROSS NEW ZEALAND



Excellence since 1976



NEW GENERATION TAPWARE



VERDE WIRE & PLASTIC MATT SHELVING



COMMERCIAL MICROWAVES



CAN OPENERS



DRINK & GRANITA MACHINES



LEADERS IN FOOD WARMING & HOLDING



SPACE SAVING PLATE STACKERS



QUALITY INDUCTION COOKING



HOT & COLD FOOD SERVING SYSTEMS



Excellence since 1976

***Welcome to our Catalogue / Price List
(All prices are in NZ Dollars)***

KEY CONTACT LIST

NEW ZEALAND HEAD OFFICE

Sales & Administration

Craig Roberts

Unit 1/ 930 Great South Road

Penrose, Auckland 1061

Tel: +64 21 423360

croberts@fsm-pl.co.nz sales@fsm-pl.com.au

www.fsm-pl.com.au

Visit our web site

www.fsm-pl.co.nz

for updates, the latest products, downloads and news.

CONTENTS

ACQUALINE	8-15
Deck Mount Pre Rinse Models	8-9
Wall Mount Pre Rinse Models	10
Deck Mount Flick Mixers, Thermostatic Mixing Valve	11
Hands Free & Time Flow Models	12
Knee Operated Tap & Cleaners Sink Models	13
Deck Mount Swing Faucet / Sink Sets	14
Wall Mount Swing Faucet / Sink Sets	15
ATLAS VERDE	16
NEW Verde Box Kits	16
BONN MICROWAVE OVENS	17-20
Speed Oven	17
Heavy Duty	18
Medium Duty	19
Light Duty	20
EDLUND CAN OPENERS	21-22
Manual & Electric Can Openers	21
Sanitation & Storage	22
GBG MACHINES	23-24
GBG Granita Machines	23
GBG Frozen Drink Machines	24
HATCO	25-47
Decorative Heat Lamps	25-26
Glo Max Strip Heaters	27
Glo Max Display Lights	28

Glo Ray Strip Heaters GRAH & GRAHL	29
Portable Heated Shelves	30
Drop-In Heated Shelves	31
Drop-in Hot / Cold and Cold Shelves	32
Drop-in Frost Top	33
Heated Chutes	34
2-Go Heated Shelves	35
Portable Food Warmers / Chip Dumps	36
Fry Stations & Multi Product Warmers	37
Conveyor, Pop Up and Programmable Toasters	38-40
Decorative Carving Stations	41
Free Standing Drawer Warmers	42-43
Pasta Cooker & Accessories	44-45
Sanitising Sink Heater	45
Built-in Heated Wells (Rectangular & Round)	46
Salamanders	47
JACKSTACK	48
Mobile Plate Racks & Covers	48
YELLOW INDUCTION	49-52
Portable Counter Top Hobs & New Drop-In	49
Drop-In Single Hob Units	50
Built-In Cooktops & Warmer	51
Multi-Zone Buffet Induction & Remote Generators	52
CARLISLE	53-78
Foodservices Products	53-78

TERMS AND CONDITIONS Effective February 2022

The following Trading Terms supersede all previously terms and condition issued by Us.

1. Interpretation

In these Trading Terms and in any quotation, offer, current catalogue, website, price list produced by Us or other agreement with Us, the following definitions apply:

"Account Application Form" means the application form completed and provided by You for the purposes of opening a credit account with Us.

"Goods" means goods supplied by Us to You (and, where the context so permits, shall include any supply of Services) and described in any quotation, offer, current catalogue, website or price list produced by Us.

"Guarantor" means the guarantor(s) described in the Account Application Form, subject to acceptance by Us.

"GST" means the goods and services tax that applies in accordance with A New Tax System (Goods & Services) Act 1999 (Cth).

"Order" means any written, verbal or electronic purchase order made by You for Goods and/or Services.

"Prices" means the prices attributable to the Goods and Services as advised by Us in any quotation, offer, current catalogue, website or price list produced by Us and "Price" shall have a corresponding meaning.

"Services" means all services supplied by Us to You and includes any advice or recommendations (and where the context so permits shall include the supply and installation of any Goods).

"Trading Terms" means these terms and conditions of trade and includes any amendment or variation.

"We" and "Us" means F.S.M. [Food Service Machinery] Pty. Ltd. (. (NZBN 9429047406339) and includes any Related Bodies Corporate (as defined in the Corporations Act 2001 (Cth)) which supplies Goods and/or Services to You (whether or not the fact is disclosed to You) and "Our" means belonging or pertaining to Us.

"You" means the person, firm or company placing an order with Us for the Goods and "Your" means belonging or pertaining to You.

2. Application of Trading Terms

(a) These Trading Terms apply to every sale of Goods and/or supply of Services by Us to You. Each Order made by You and accepted by Us will be an individual contract for those Goods and/or Services in accordance with these Trading Terms.

(b) Subject to any special trading terms agreed to between You and Us and recorded in Your Account Application Form or separately in writing, these Trading Terms (together with any quotation, offer, current catalogue, or price list produced by Us) shall comprise in entirety Our terms and conditions of trade.

(c) In the event of any inconsistency between these Trading Terms and any other document, these Trading Terms shall prevail and any trading terms nominated by You are expressly excluded. Any warranty, representation or guarantee not included or provided for in these Trading Terms is of no effect.

(d) If any part of these Trading Terms, or the application of these Trading Terms to any person or circumstance, is or becomes invalid or enforceable, the remaining provisions of these Trading Terms are not affected and are valid and enforceable to the fullest extent permitted by law.

(e) We may amend these Trading Terms from time to time without notice to You and You will be deemed to have had knowledge of such amendments and have accepted these Trading Terms as amended if You continue to purchase Goods and/or Services from Us after such amendment. Each subsequent supply of Goods and/or Services by Us to You will be in accordance with these Trading Terms as amended.

3. Agreement

(a) Any quotation or offer produced by Us is subject to review, amendment or withdrawal at any time prior to acceptance by You or the expiry of the quotation or offer (whichever occurs first).

(b) Subject to (c) of this clause, Our quotation or offer will be deemed to have been accepted by You and a binding agreement entered into with You on the date We receive Your Order. Any Order which has been accepted by Us may not be cancelled by You without Our written consent (which We may withhold in Our absolute discretion) and then only on the basis that You will indemnify Us in full against all loss (including loss of profit), costs (including the cost of labour and materials used), damages, charges and expenses (including legal costs on a full indemnity basis) incurred by Us as a result of such cancellation. Cancellation of any Orders for Goods which are non-standard manufacture or non-stock items will not be accepted.

(c) We reserve the right to decline, in whole or in part, any Order received from You in Our absolute discretion.

(d) You are solely responsible for determining whether the Goods and Services are suitable for Your intended purposes and meet Your requirements and You acknowledge that no oral or written information, representation or advice given by Us (other than as contained in these Trading Terms) creates a warranty from Us or in any way increases the scope of these Trading Terms.

(e) You agree to notify Us in writing of any change in the ownership or control of Your business structure not less than 7 days prior to such change taking effect and You indemnify Us against any loss or damage We may incur as a result of Your failure to provide such notification.

4. Documents

Any clerical or typing errors, misprints or other similar errors in any document produced by Us in respect of Goods and/or Services are subject to correction by Us by either amending or re-issuing the affected document (as the case requires). We shall not be liable for any cost, expense or damage incurred by You as a result of any correction of any document produced by Us.

5. Intellectual Property

You acknowledge and agree that:

(a) any intellectual property rights in respect of the Goods and Services (including, but

not limited to, rights to design, copyright, patents or trademarks in respect of all drawings, designs, specifications and other information provided by Us in connection with any quotation, offer, current catalogue, website, price list produced by Us) remain Our sole and exclusive property and must remain confidential and You will not attempt to claim any such intellectual property rights in respect of either the Goods and Services or any modification or improvement of the Goods and Services;

(b) You must not attempt to modify or reverse engineer the Goods and Services; and
(c) in all cases where You have provided the design for any Goods and Services, We will not accept any responsibility for any infringement of any design, copyright, patents or trademarks or other intellectual property in connection with the execution of Your Order and You agree to indemnify Us against claims for infringement or unauthorised use of such intellectual property arising out of the manufacture or use of such Goods and Services.

6. Prices and Charges

(a) You agree to buy and We agree to sell the Goods and Services for the Prices.
(b) All Prices and all amounts payable to Us are exclusive of GST or any other applicable government tax or duty, unless otherwise indicated. You must pay all such taxes and duties in connection with those amounts.

(c) The Prices include the cost of Our standard packaging for the Goods. The cost of any special packaging materials or techniques requested by You in connection with the Goods must be paid for by You in addition to the Prices.

(d) We reserve the right, from time to time but prior to issuing any invoice to You, to increase the Prices:

(i) to take account of increases in the cost of supplying the Goods and/or Services to You (which may include, but are not limited to, increases in the cost of energy, materials, labour, equipment or delivery) which are due to any factor beyond Our reasonable control or are due to Your failure to provide adequate information or instructions; or

(ii) to correct, without any liability on Our part, any errors or omissions quotation, offer, current catalogue, website or price list produced by Us.

7. Payment

(a) We reserve the right to pass on to You any additional costs (including merchant fees) incurred by Us where You pay Us by credit card (if applicable).

(b) If We have not provided credit terms to You, You must pay for the Goods prior to delivery.

(c) If We have provided credit terms to You, You must pay for any Goods and/or Services provided to You within the time period stated in Our invoice or statement for such Goods and/or Services. If We have not stated a time period for payment, You must pay for the Goods and/or Services within 30 days of the end of the month in which we issued Our invoice or statement for the Goods and/or Services.

(d) We may set, alter or withdraw credit limits and terms in Our absolute discretion and without giving prior notice to You or providing reasons.

(e) Payments due to Us must be made without any deduction or set-off. We may apply the amounts paid to Us in payment of any amount owed by You. If You dispute Our invoice or statement, You must still pay the entire amount. We will refund any agreed amount following resolution of the dispute.

(f) If You fail to pay Our invoice or statement (whether in whole or in part) by the due date, without limiting any other provision in these Trading Terms, We may (in Our absolute discretion):

(i) suspend or cancel any further production and/or delivery of any Goods or supply of any Services (whether under an existing or new Order) until full payment of all outstanding amounts owed to Us (including accrued interest if applicable) has been made;

(ii) charge interest on any amount outstanding in respect of Our invoices, at the rate of 1.5% per month, such interest to be calculated daily and compounded monthly), until full payment has been made (such interest rate to be subject to amendment from time to time by Us in Our absolute discretion;

(iii) exercise a general lien on any of Your property within Our possession or control to cover the outstanding amount for the Goods and/or Services;

(iv) withdraw (in full or in part) any discount, concession, allowance or benefit which was previously offered to You; and

(v) recover from You, in addition to the outstanding amount, all costs incurred by Us arising out of or in connection with collecting the outstanding amount (including, but not limited to, expenses and fees associated with or paid to or on account of solicitors, legal advisers, mercantile agents and other agents acting on Our behalf) and the amount payable will be a debt due and payable without demand from the date on which We incur liability for the cost, expense or fee.

8. Security Interest and the Personal Property Securities Act 2009 ("PPSA")

If you have a current credit facility in place with Us, You acknowledge and agree that the following terms apply:

(a) We may require You to provide security for any Order placed by You as a condition of accepting Your Order and the terms of the Personal Property Securities Act 2009 (Cth) ("PPSA") apply to all transactions made under these Trading Terms.

(b) You acknowledge and agree that You will:

(i) grant a security interest in all present and after acquired Goods as security for all amounts owing now and in the future by You to Us;

(ii) do all things and sign all documents as are necessary and reasonably required to enable Us to acquire a perfected security interest in all Goods supplied;

(iii) provide such information as is required to enable registration of a 'Purchase Money Security Interest' (as that term is defined in the PPSA) ("PMSI");

(iv) not, without obtaining Our prior written consent, change Your name or initiate any change to any registered documentation, or act in any manner which would impact on Our registered security interest; and

(v) waive or exclude the application of such sections of the PPSA as We may require, subject to those sections being capable of exclusion.

(c) You further acknowledge that a PMSI is granted by You, in priority to all other

Continued >

TERMS AND CONDITIONS (continued)

creditors, in favour of Us and in respect of all Goods We supply to You from time to time, as security for Your payment obligations to Us. You agree to indemnify Us for any liability for all costs (including legal costs on a full indemnity basis) incurred by Us in relation to any security interest granted by You (including, but not limited to, registration, maintenance, enforcement or discharge of any security interest).

(d) We reserve the right at any time to make such amendments, alterations to this 'Security Interest' clause as We may, in Our absolute discretion, determine are necessary to protect Our security interests.

9. Title and Risk

(a) Title to and ownership of the Goods shall not pass to You until We have received full payment for the Goods and for any other amounts owing by You in relation to any other matter (including payments in respect of other goods or services provided to You from time to time) and You shall hold the Goods (including where such Goods have been converted or changed by any process) as fiduciary bailee and agent for Us.

(b) Risk in the Goods shall pass to You upon completion of delivery in accordance with these Trading Terms.

(c) You acknowledge that We hold a PMSI (as defined in clause 8) in respect of any Goods supplied to You until We have received full payment in respect of such Goods. You must not pledge, or in any way charge by way of security or indebtedness, any of the Goods until We have received full payment.

(d) Upon taking delivery of the Goods and until We receive full payment for the Goods and for any other amounts owing by You in relation to any other matter, until the Goods are sold by You in the ordinary course of your business, You must:

(i) keep the Goods in Your control and custody and not permit any other person to have possession, custody or control of the Goods;

(ii) keep the Goods separate from any other items or goods in Your possession and mark the Goods to clearly show that the Goods belong to Us;

(iii) not pledge, or in any way charge by way of security or indebtedness, any of the Goods;

(iv) permit Our nominated representative to attend Your premises on prior notice to inspect the Goods; and

(v) deposit all proceeds from the sale of the Goods into a separate and identifiable account, not mix such sale proceeds with any other money and account to Us for such sale proceeds;

and We may trace all such sale proceeds received by You through the relevant account or any other account maintained by You. In addition, You irrevocably appoint Us as Your attorney to recover any such sale proceeds from any purchaser to whom You have on-sold the Goods and to exercise Your rights under any agreement with such purchaser (including rights of repossession and resale of the Goods) provided that We undertake not to exercise such rights as Your attorney unless You have failed to comply with Your payment obligations to Us under these Trading Terms.

(e) Without prejudice to any of Our other rights, if You fail to comply with these Trading Terms, if You cease to be able to pay Your debts as they become due or if You become subject to any form of insolvency administration:

(i) all amounts owing by You to Us shall immediately become due and payable;

(ii) We have the right to immediate possession of the Goods and You irrevocably authorise Us to enter any premises occupied by You at the time upon reasonable notice to You, without liability for trespass or any resulting damage, and take possession of the Goods. You agree to indemnify Us and hold Us harmless from all claims arising out of or in connection with Us taking possession of the Goods in accordance with this clause;

(iii) We may retain all amounts paid to us on account of the Goods and suspend or cancel any further production and delivery of Goods for You;

(iv) We shall be entitled, but not obligated, to resell any Goods repossessed by Us in accordance with this clause; and

(v) We may recover from You all reasonable costs incurred by Us in connection with any Goods repossessed under this clause (including legal costs on a full indemnity basis) and the amount payable will be a debt due and payable without demand from the date on which We incur liability for the cost, expense or fee.

(f) If, at the time We seek to take possession of the Goods in accordance with this clause, the Goods have been incorporated by You in any other item or goods, We will be treated as owners of such other items or goods together with You, as tenants in common in proportion to our respective contributions.

10. Delivery

(a) The delivery dates and completion times contained in any quotation, offer or price list provided to You are estimates only, unless expressly stated to be an essential term and may be varied at any time by Us depending upon the availability of Goods, materials, labour and other contingencies. All prices are quoted ex-warehouse Auckland.

11. Force Majeure

We will not be liable for any failure to perform, or delay in performance of, any obligation where such failure or delay is due to anything beyond Our reasonable control including, but not limited to, adverse weather or terrain, strikes, lockouts and other industrial action, material shortages, failure of any of Our suppliers to supply, accidents, power or data transmission failure, breakdowns of plant or machinery, war, changes of government, import or export regulations or embargoes.

12. Inspection and Return of Goods

(a) You will be deemed to have accepted the Goods, free from any defect or other non-conformity, unless We receive a substantiated claim from You within 7 days from the date of delivery and/or installation of the Goods in accordance with these Trading Terms.

(b) Except where Goods supplied by Us are defective and subject to any warranty:

(i) Goods will only be accepted for return if You have given prior written notice to Us (confirming Your reasons for returning the Goods and stating the applicable invoice number) of Your intention to return the Goods and We have notified You in writing with a completed GRN form that We will accept such return, and that a copy of the GRN Form

supplied by us accompanies the goods being returned;

(ii) We may refuse to accept Goods where they are used, no longer in their original packaging or are returned more than 2 weeks after delivery to You;

(iii) We will refuse to accept the return of any Goods which are non-standard manufacture or non-stock items where such Goods have been correctly delivered by Us;

(iv) delivery of all Goods returned by You must be arranged with Your carrier and is at Your expense and risk; and

(v) in the event that We agree to accept the return of any Goods, You will be required to agree to pay a minimum 15% restocking fee, such fee to be subject to amendment from time to time by Us in Our absolute discretion.

(c) We will only accept the return of Goods from You if the Goods are in the same condition as when the Goods were originally delivered to You, provided that Our acceptance of Goods returned by You is not an acceptance of or granting of credit to You.

13. Limitation of Liability and Warranties

(a) The Competition and Consumer Act 2010 (Cth) may imply certain conditions and warranties into these Trading Terms that cannot be excluded or modified. These Trading Terms do not exclude or modify any of those conditions if to do so would contravene that law or make any part of these Trading Terms void.

(b) Where our products are used in a Commercial environment, Subject to the provisions of this clause 13, We will repair or replace any Goods which are manufactured or imported by Us where We, in Our absolute discretion, determine that such Goods, having regard to the materials, workmanship and the reasonable and recommended conditions of use and maintenance, are defective within the period of Warranty (as specified below):

All products within 13 months (Parts & Labour), from the date of delivery to the original Purchaser with the exception of the following:

Acquiline Tapware - Two Year on-site warranty - excludes faulty installation, sensitivity adjustments on electronic models, failure to instal pressure limiting devices where required.

Bonn Ovens / Microwaves:

Bonn Models CM-1042T, CM-1051T - Back to Base 24 months parts and 13 months labour warranty.

Bonn Models CM-902T - Back to Base 13 months parts and 13 months labour warranty.

Bonn Models CM-1901T and CM-1401T - On Site 24 months parts and 13 months labour.

Yellow Induction - Back to Base Warranty models: All Countertop.

Subject to the following conditions:

(i) this warranty will cover parts and labour unless specified otherwise, subject to the following limitations:

(A) damage to cutting blades, toaster elements, light globes, infrared tubes, quartz tubes or any glass items;

(B) where FSM is not responsible for installation - damage caused by improper installation or improper connection to incorrect gas, voltage, incorrect pressure or poor quality water;

(C) damage caused during transit or by accident;

(D) damage caused by negligence, abuse, unauthorised repair or the use of unauthorised spare parts;

(E) damage caused by improper cleaning, maintenance or operation;

(F) damage caused by voltage or gas conversion, pilot light adjustments, thermostat calibrations or any unauthorized alteration or modification;

(G) FSM's liability under this warranty is limited to the repair or replacement of defective Goods and all other costs (including, without limitation, any travel costs, labour costs, overtime rates, installation costs, freight and delivery costs to and from FSM premises to the premises of an authorised repairer, or similar surcharges, fees and costs arising out of a warranty claim are excluded:

(ii) all warranty repair work will be performed between the hours of 8.30 am and 4.30 pm on normal working days;

On site warranty services are limited to sites within 50km from the nearest FSM authorised service agent.

With respect to "Back to Base" warranties, FSM can sell or dispose of any goods:

(i) Not collected by customer or

(ii) Where customer refuses to accept delivery of those goods within 60 days of FSM notifying customer goods are available for collection and/or delivery.

(iii) the warranty period in respect of any spare parts or replacement parts provided under this warranty is limited to 3 months from the delivery of such spare parts or the installation of such replacement parts;

(iv) where the payment terms under these Trading Terms have not been complied with, warranty claims will not be accepted in respect of such Goods;

(v) Risk in any Goods shall remain with You while such Goods are in Our possession for the purposes of assessing a warranty claim and FSM, its servants and agents will not be responsible for any damage caused to the Goods while in Our possession.

(vi) To obtain the benefit of this warranty, You must notify Us in writing immediately upon becoming aware of the alleged defect and in any event within 13 months (or other period as stipulated under item 13) of delivery of the Goods to You (3 months from the delivery of any spare parts or the installation of replacement parts under this warranty).

To the extent that any Goods are not covered under the warranty described in this clause 13(b) but are subject to the original manufacturer's or the original supplier's warranty, FSM will pass on the benefit of such warranty to the extent permitted by law.

(c) Subject to (a) and (b) of this clause 13 and without limiting the terms of any written warranty given separately by Us, all warranties and conditions that may be implied into these Trading Terms are excluded and Our liability for breach of any implied condition or warranty that cannot be excluded is limited (at Our option) to:

(i) in respect of Goods: the repair or replacement of those Goods or reimbursement

Continued >

TERMS AND CONDITIONS (continued)

of the cost of having those Goods repaired or replaced or refunding to You any payments made in respect of the Goods; and

(ii) in respect of Services: the re-supply of the Services or reimbursement of the cost of supplying the Services again or refunding to You any payments made in respect of the Services.

(d) Despite any other provision of these Trading Terms, to the extent permitted by law, We have no liability to You nor will You be entitled to claim against Us in respect of:

(i) any loss or damage caused by delay in delivery of the Goods or supply of the Services;

(ii) any death or injury arising out of or in connection with the supply of the Goods and/or Services or otherwise at law or in equity;

(iii) any consequential loss or damage (including, but not limited to, loss of profit, loss of revenue, loss of expected savings and opportunity costs) arising out of or in connection with the supply of the Goods and/or Services or otherwise at law or in equity; and

(iv) (if applicable) any loss or damage to Your property or any premises occupied by You arising out of or in connection with Our reasonable installation of the Goods and it is Your responsibility to provide adequate facilities to Us during such installation and to arrange the removal of all waste and hazardous material in connection with the installation process.

(e) You acknowledge that You have not relied on any representation made by Us which is not expressly stated in these Trading Terms.

(f) You acknowledge that You must ensure that the Goods are used and installed (if applicable) in a prudent and professional manner and in accordance with any specifications or instructions which were supplied with the Goods. You indemnify Us against all loss, liability, cost (including legal costs on a full indemnity basis) and expense incurred by Us as a result of any claim made or action brought in connection with the Goods or their use, other than a claim or action brought by You under these Trading Terms or a condition or warranty implied by law which is not excluded by these Trading Terms.

(g) You acknowledge that the exclusions and limitations in this clause are customary for suppliers of goods and services equivalent to the Goods and Services and are fair and reasonable given the nature of the Goods and Services and the applicable Prices.

(h) This clause shall survive termination of these Trading Terms

14. Consent to credit check and Privacy Act

(a) By signing the Account Application form, You acknowledge and agree that the Privacy Act 1988 (Cth) allows Us to give a credit reporting agency certain personal information about You at any time after signing such form for the purpose of assessing Your credit worthiness.

(b) You further acknowledge and agree that We may contact any trade reference provided by You or any credit provider and We may acquire information from them or provide information to them in relation to Your credit worthiness.

15. Guarantee and Indemnity

(a) The Guarantor hereby guarantees the due and punctual payment by signature of all monies that becomes due and payable by You to Us under these Trading Terms and also the due and punctual performance by You of Your obligations pursuant to these Trading Terms (the "Guarantee").

(b) In consideration for Us entering into these Trading Terms with You, the Guarantor hereby charges in Our favour the whole of the Guarantor's estate and interest, legal and equitable, in the Guarantor's personal and real property to secure the Guarantor's obligations pursuant to these Trading Terms.

(c) Without limiting Our rights under these Trading Terms, the Guarantor acknowledges and agrees that the charge on the Guarantor's property shall provide a caveatable interest in Our favour and the Guarantor consents to Us registering Our interest in the Guarantor's property, including by way of a caveat.

(d) The Guarantee is a continuing guarantee and shall not be discharged in whole or in part by the payment at any time of any part of the money payable by You pursuant to these Trading Terms or by settlement of account, intervening payment, or other matter or thing whatsoever.

(e) The Guarantee shall not be affected or prejudiced by any variation or modification at any time to these Trading Terms.

(f) The Guarantee shall at all times be valid and enforceable against the Guarantor notwithstanding:

(i) that no demand for payment has been made to You; and
(ii) that You were prohibited (whether expressly or by implication) by law, contract or otherwise from entering into these Trading Terms or lacked capacity, power or authority to enter into these Trading Terms.

(g) The Guarantee is irrevocable and shall not be affected by the death, bankruptcy or incapacity of any of the Guarantors.

(h) If any payment made by You to Us is subsequently avoided or set aside by reason of any statutory provision or otherwise, such payment shall not prejudice or otherwise affect the Guarantee, or Our rights pursuant to this clause 15, to the intent that We shall, with respect to its rights recover pursuant to this clause 15 any monies secured, be restored to the same position in which We would have been had such payment not been made.

(i) In addition, the Guarantor agrees to indemnify Us in respect of all costs, charges and expenses whatsoever, which We may incur by reason of any default by You under or in relation to these Trading Terms.

(j) The Guarantor is liable to pay, and indemnify Us for, Our reasonable expenses incurred in enforcing the Guarantee.

(k) If more than one party signs as Guarantor, in this clause 15 each reference to "Guarantor" is a reference to them jointly and each of the individually.

16. General

(a) We may sub-contract the production, manufacture, supply or delivery of all or some of the Goods and Services.

(b) Any failure by Us to insist on strict compliance with these Trading Terms or any delay by Us in exercising Our rights under these Trading Terms will not constitute a variation or

waiver of any provision of these Trading Terms or of any right available to us.

(c) If part of all of any provision of these Trading Terms or its application to any person or circumstance is held to be illegal or unenforceable, the provision will be interpreted so as to ensure it is not illegal or unenforceable. If any provision or part of it cannot be so interpreted, the provision or relevant part of it will be severed from these Trading Terms and the remaining provisions of these Trading Terms will continue in force.

(d) Where You are comprised of 2 or more persons, an agreement or obligation to be performed or observed by You binds those persons jointly and each of them severally.

(e) Any notice or document required to be served under these Trading Terms will be sufficiently served if delivered or posted by pre-paid post to the address of that party as notified by that party from time to time in writing. If the notice or document is posted, service will be deemed to have been effected 3 days after the date on which the document or notice was posted.

17. Governing Law

These Trading Terms are governed by the laws of New Zealand. All parties submit to the non-exclusive jurisdiction of the Courts of Auckland, New Zealand.

Continued >

There's more than five good reasons to choose Acqualine.

The Acqualine range of quality tapware and pre-rinse units heralds a new era of reliable, quality tapware to the market with a TWO YEAR on-site parts and labour warranty – designed by professionals with the features you would expect for your kitchen. Features like 256mm swing faucet on full height pre-rinse models, six star Wels rated spray gun and quality construction with 100mm levers with a choice of 100 or 200mm flick mixers and more.

Watermark approved and Wels rated to comply with all Australian regulations, and supplied with our exclusive FIVE YEAR* on-site parts and labour warranty for real peace of mind.

All units come packed with full instructions, fittings and hose connections (model dependant).

DECK MOUNT PRE RINSE MODELS

AQD1500 DECK MOUNT

Deck Mount Pre Rinse, complete with wall bracket, 256mm Add on swing faucet, 1/4 turn 100mm lever operated ceramic disc taps and 6 Star rated spray gun, 4 Star rated pot filler as shown. Single hole mount. Overall height: 1073mm. Hose length 845mm. Operating water pressure Min 50kPA, Max 350kPA.

**TWO YEAR
ON-SITE WARRANTY***

LIST PRICE EA. \$1140

6 BUY PRICE EA. \$1130

12 BUY PRICE EA. \$1115

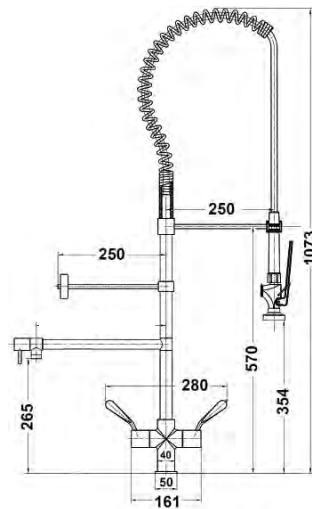

AQD1500LH DECK MOUNT *LOW HEIGHT*

Deck Mount Pre Rinse, Low Height Model, complete with wall bracket, 1/4 turn 100mm lever operated ceramic disc taps and 6 Star rated spray gun, Single hole mount. Overall height: 600mm. Hose length 845mm. Operating water pressure Min 50kPA, Max 350kPA.

**TWO YEAR
ON-SITE WARRANTY***

LIST PRICE EA. \$905

6 BUY PRICE EA. \$893

12 BUY PRICE EA. \$876

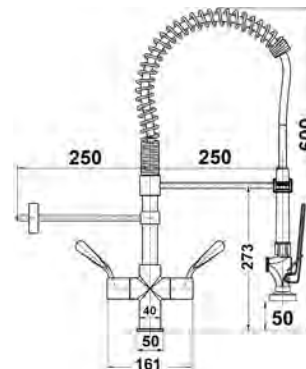

(Deck Mount units continued...)

* Five Year on-site warranty covers manufacturing defects, and excludes faulty installation, sensitivity adjustments on electronic models, failure to instal pressure limiting devices where required.

There's more than five good reasons to choose Acqualine.

DECK MOUNT PRE RINSE MODELS (cont.)

AQD1200 DECK MOUNT

Deck Mount Pre Rinse, complete with wall bracket, 256mm swing faucet, single lever flow and temperature control, and 6 Star rated spray gun, 4 Star rated pot filler. Single hole mount. Overall height: 960-1030mm.

Hose length 845mm.

Operating water pressure Min 50kPA, Max 350kPA.

**TWO YEAR
ON-SITE WARRANTY***

LIST PRICE EA. \$1020

6 BUY PRICE EA. \$1000

12 BUY PRICE EA. \$975

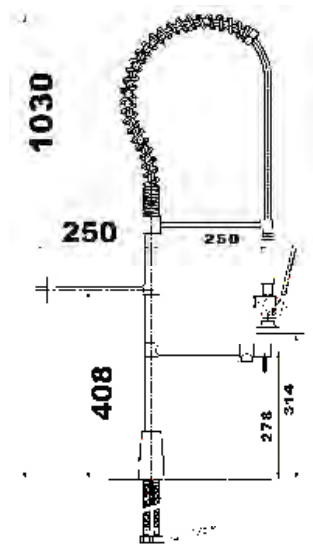

* Five Year on-site warranty covers manufacturing defects, and excludes faulty installation, sensitivity adjustments on electronic models, failure to instal pressure limiting devices where required.

There's more than five good reasons to choose Acqualine.

WALL MOUNT PRE RINSE MODELS

AQW1500 WALL MOUNT EXPOSED BREECH

Wall Mount Pre Rinse, complete with wall bracket, 256mm Add on swing faucet, 1/4 turn 100mm lever operated ceramic disc taps and 6 Star rated spray gun, 4 Star rated pot filler as shown. Two hole mount. Hose length 845mm. Operating water pressure Min 50kPA, Max 350kPA. Overall height: 1023mm.

TWO YEAR ON-SITE WARRANTY*

LIST PRICE EA. \$1330

6 BUY PRICE EA. \$1320

12 BUY PRICE EA. \$1300

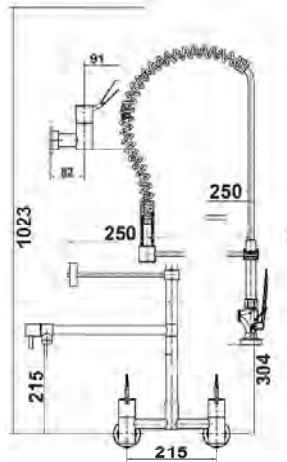

AQW1500CB WALL MOUNT CONCEALED BREECH

Wall Mount Pre Rinse, complete with wall bracket, 256mm Add on swing faucet, 1/4 turn 100mm lever operated ceramic disc taps 6 Star rated spray gun, 4 Star rated pot filler as shown. Three hole mount. Hose length 845mm. Operating water pressure Min 50kPA, Max 350kPA. (Breech by others). Overall height: 713mm.

TWO YEAR ON-SITE WARRANTY*

LIST PRICE EA. \$1080

6 BUY PRICE EA. \$1060

12 BUY PRICE EA. \$1030

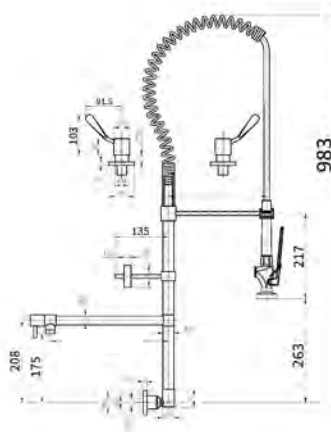

* Five Year on-site warranty covers manufacturing defects, and excludes faulty installation, sensitivity adjustments on electronic models, failure to instal pressure limiting devices where required.

There's more than five good reasons to choose Acqualine.

DECK MOUNT FLICK MIXER MODELS

AQD5200 DECK MOUNT FLICK MIXER 200mm swing spout

Deck Mount Flick Mixer, complete with 200mm Swing Spout, 4 Star rated, one hole mount, complete with flexible fittings. Cutout size: 35-36mm Dia. Operating water pressure Min 50kPA, Max 350kPA.

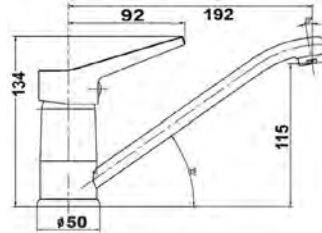

**TWO YEAR
ON-SITE WARRANTY***

LIST PRICE EA. \$250

6 BUY PRICE EA. \$244

12 BUY PRICE EA. \$232

AQD5100 DECK MOUNT FLICK MIXER 100mm spout

Deck Mount Flick Mixer, complete with 100mm Fixed Spout, 4 Star rated, one hole mount, complete with flexible fittings. Cutout size: 35-36mm Dia. Operating water pressure Min 50kPA, Max 350kPA.

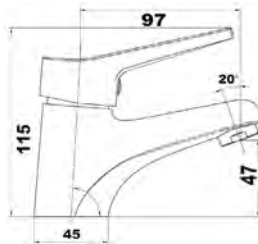

**TWO YEAR
ON-SITE WARRANTY***

LIST PRICE EA. \$238

6 BUY PRICE EA. \$238

12 BUY PRICE EA. \$226

AQ6000 THERMOSTATIC MIXING VALVE 15/20mm

Critical for supplying safe/desirable water temperatures to a Hands Free or Time Flow tapset. Output temperature range 35-50°C. Operating water pressure Min 20kPA, Max 350kPA.



**TWO YEAR
ON-SITE WARRANTY***

LIST PRICE EA. \$406

6 BUY PRICE EA. \$395

12 BUY PRICE EA. \$383

* Five Year on-site warranty covers manufacturing defects, and excludes faulty installation, sensitivity adjustments on electronic models, failure to instal pressure limiting devices where required.

There's more than five good reasons to choose Acqualine.

ELECTRONIC HANDS FREE & TIME FLOW MODELS

AQD4002 DECK MOUNT HANDS-FREE SENSOR TAP

Modern Deck Mounted Hands Free Sensor Tap, single hole mount, complete with flexible fittings, downward facing sensor, Mains and battery backup, 6 Star rating. Includes one connection tail and hardware. Stop taps recommended (not supplied). Operating water pressure Min 50kPA, Max 350kPA.

**TWO YEAR
ON-SITE WARRANTY***

LIST PRICE EA. \$900
6 BUY PRICE EA. \$880
12 BUY PRICE EA. \$860

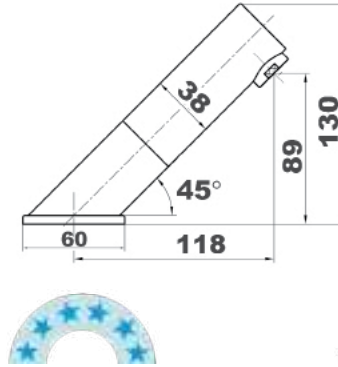

AQW4003 WALL MOUNT HANDS-FREE SENSOR TAP

Modern Wall Mounted Hands Free Sensor Tap, single hole mount, complete with flexible fittings, downward facing sensor, Mains and battery backup, 6 Star rating. Includes one connection tail and hardware. Stop taps recommended (not supplied). Operating water pressure Min 50kPA, Max 350kPA.

**TWO YEAR
ON-SITE WARRANTY***

LIST PRICE EA. \$910
6 BUY PRICE EA. \$890
12 BUY PRICE EA. \$875

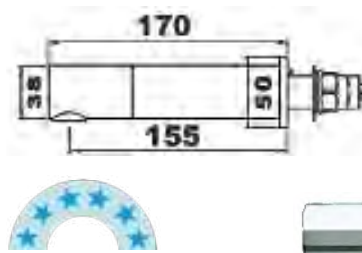

AQD745 DECK MOUNT TIME FLOW TAP

Deck mounted Time Flow Tap. 15 Seconds. Single hole mount, 6 Star rating. Includes one connection tail and hardware. Supplied with Blue Red and Yellow button. Operating water pressure Min 50kPA, Max 350kPA. Optimum 250-350kPA.

**TWO YEAR
ON-SITE WARRANTY***

LIST PRICE EA. \$275
6 BUY PRICE EA. \$265
12 BUY PRICE EA. \$250

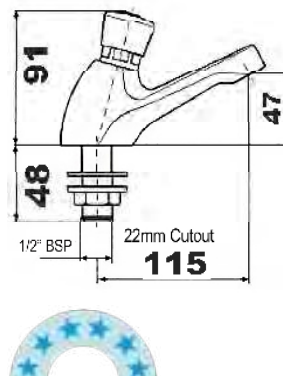

* Five Year on-site warranty covers manufacturing defects, and excludes faulty installation, sensitivity adjustments on electronic models, failure to instal pressure limiting devices where required.

There's more than five good reasons to choose Acqualine.

AQD780 KNEE OPERATED TIMER BASIN TAP SET

Includes deck mount fixed gooseneck outlet, 325mm lever / knee operated time-flow and connections. Six Star rated. Operating water pressure Min 50kPA, Max 350kPA.

**TWO YEAR
ON-SITE WARRANTY***

LIST PRICE EA. \$495

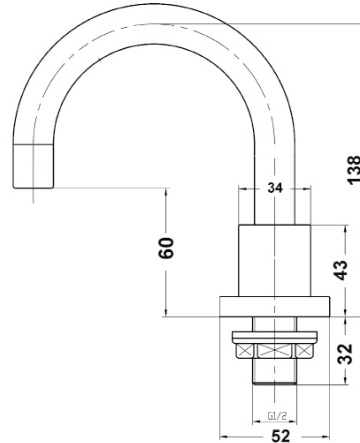
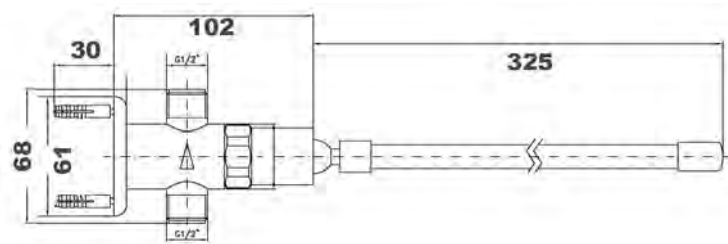

AQW1836 CLEANERS SINK FAUCET SET with wall bracket support

Quality Wall mounted Cleaners Sink model with cable supported Spout and Bucket Hook. 4 Star rated. Operating water pressure Min 50kPA, Max 350kPA.

**TWO YEAR
ON-SITE WARRANTY***

LIST PRICE EA. \$1700

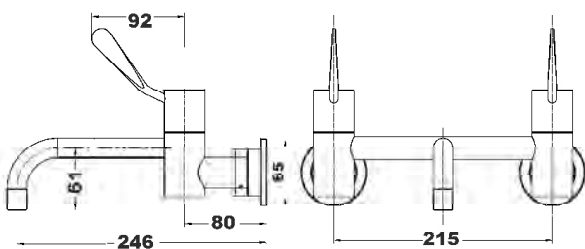

* Five Year on-site warranty covers manufacturing defects, and excludes faulty installation, sensitivity adjustments on electronic models, failure to instal pressure limiting devices where required.

There's more than five good reasons to choose Acqualine.

AQD3150 DECK MOUNT FAUCET WITH 180MM SPOUT

Deck Mounted 180mm Swing Faucet, with 100mm Lever operation, one hole mount, complete with flexible fittings. Ceramic cartridges, 1/4 turn levers, rugged construction and high quality finish. 4 Star rated. Operating water pressure Min 50kPA, Max 350kPA.

**TWO YEAR
ON-SITE WARRANTY***

LIST PRICE EA. \$520

6 BUY PRICE EA. \$510

12 BUY PRICE EA. \$485

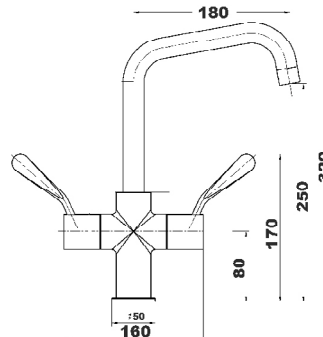

AQD3300CB DECK MOUNT WITH 300MM SPOUT

Deck Mounted 300mm Swing Faucet, with Lever operation, concealed breach, three hole mount. Ceramic cartridges, 1/4 turn 100mm levers, rugged construction and high quality finish. 4 Star rated. Operating water pressure Min 50kPA, Max 350kPA. (Breach by others).

**TWO YEAR
ON-SITE WARRANTY***

LIST PRICE EA. \$540

6 BUY PRICE EA. \$530

12 BUY PRICE EA. \$510

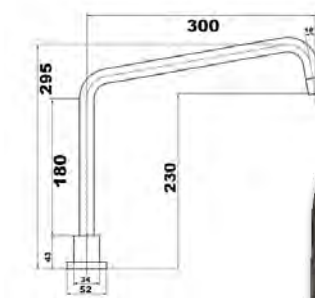

(Tap detail common to all Concealed Breach models, see next page for drawing).

AQD3180CB DECK MOUNT WITH 180MM SPOUT

Deck Mounted 180mm Swing Faucet with Lever operation, concealed breach, three hole mount. Ceramic cartridges, 1/4 turn 100mm levers, rugged construction and high quality finish. 4 Star rated. Operating water pressure Min 50kPA, Max 350kPA. (Breach by others).

**TWO YEAR
ON-SITE WARRANTY***

LIST PRICE EA. \$515

6 BUY PRICE EA. \$500

12 BUY PRICE EA. \$480

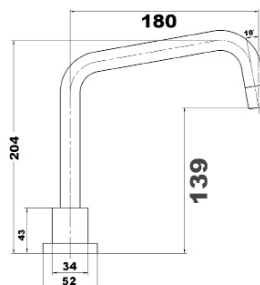

* Five Year on-site warranty covers manufacturing defects, and excludes faulty installation, sensitivity adjustments on electronic models, failure to instal pressure limiting devices where required.

There's more than five good reasons to choose Acqualine.

WALL MOUNT FAUCET/SINK SETS

AQW3300CB WALL MOUNT WITH 300MM SPOUT

Wall Mounted 300mm Swing Faucet, with Lever operation, concealed breech, three hole mount. Ceramic cartridges, 1/4 turn 100mm levers, rugged construction and high quality finish. 4 Star rated. Operating water pressure Min 50kPA, Max 350kPA. (Breach by others).

**TWO YEAR
ON-SITE WARRANTY***

LIST PRICE EA. \$520

6 BUY PRICE EA. \$510

12 BUY PRICE EA. \$495

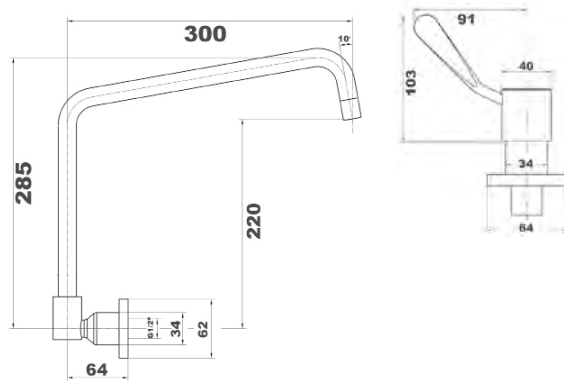

AQW3180CB WALL MOUNT WITH 180MM SPOUT

Wall Mounted 180mm Swing Faucet with Lever operation, concealed breech, three hole mount. Ceramic cartridges, 1/4 turn 100mm levers, rugged construction and high quality finish. 4 Star rated. Operating water pressure Min 50kPA, Max 350kPA. (Breach by others).

**TWO YEAR
ON-SITE WARRANTY***

LIST PRICE EA. \$510

6 BUY PRICE EA. \$500

12 BUY PRICE EA. \$490

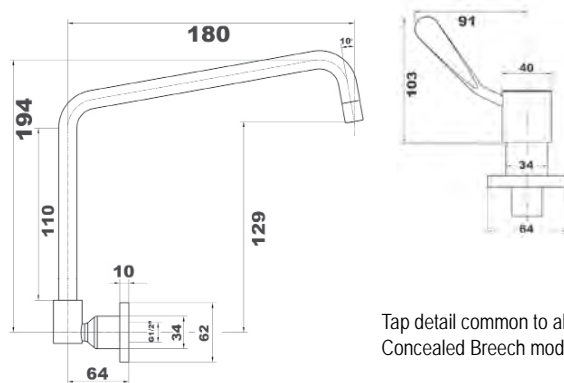

Tap detail common to all Concealed Breech models.

* Five Year on-site warranty covers manufacturing defects, and excludes faulty installation, sensitivity adjustments on electronic models, failure to instal pressure limiting devices where required.

4 SHELF WIRE SHELVING BOX KITS



WHAT'S IN THE BOX:

- 4 x POSTS
- 4 x WIRE SHELVES
- 4 x PACKS OF SPLIT SLEEVES

4-SHELF EPOXY WIRE SHELVING UNIT

- Wire design allows for air circulation and minimal dust buildup
- Shelves easily adjust to your exact needs
- 544kg load capacity per unit (136kg per shelf)
- Ideal storage solution for any commercial, food service, medical setting, or home application
- Shelves and posts manufactured with antimicrobial green epoxy finish
- Includes posts, shelves, and all needed hardware
- No tools required for super easy assembly



ASSEMBLES IN MINUTES

CODE	455 DEEP - 4 SHELF BOX KITS	\$
V18307SET	760mm SHELVES (18X30") x1830mmH	221
V18367SET	915mm SHELVES (18X36") x1830mmH	238
V18427SET	1065mm SHELVES (18X42") x1830mmH	255
V18487SET	1220mm SHELVES (18X48") x1830mmH	290

NEW FEATURE
Posts are now half size for easier shipping!

HIGH-SPEED ACCELERATED COOKING OVEN

The Bonn Speedichef high-speed accelerated cooking oven utilizes a combination of forced convection, high speed tuned impinged air, top launched microwave to shorten the cook times significantly. It can bake, roast, toast, brown, and crisp foods up to 10 times faster than conventional methods while cooking evenly and consistently.

10 times faster than a conventional oven

Quiet – AVG 48 dB in standby mode

Uses less energy AVG 2.0kw/h

Bonn iQ Speedichef SCIQ2

- ▶ Top & Bottom impinged air
- ▶ Touch mode interface with smart menu system, controls are intuitive and simple to use
- ▶ Three “Set TEMP” modes to meet different temperature requirement.
- ▶ Temperature setting: 0-280°C
- ▶ Total 432 recipes with multi-stage programming (Up to 6 stages for each recipe)
- ▶ Variable-speed, vertically-recirculated air convection and impingement, can heat, brown, and crisp powerfully and intelligently with low noise.
- ▶ Stirrer to help ensure even distribution of air and microwave.
- ▶ Edit recipe and image on both oven and PC
- ▶ USB port to load recipes and photos
- ▶ Built-in catalytic converter breaks down grease-laden vapors, allowing for ventless operation.
- ▶ Allows the use of the metal trays, pans, screens, simplifies cooking.
- ▶ Built-in self-diagnostics.
- ▶ Infra-red elements tilt-up for cleaning
- ▶ Warranty: 13 months parts and labour (onsite).
- ▶ Supplied with 15 amp Cord + Plug

Dimensions: (WxDxH) 383mm x 693mm x 610mm

LIST PRICE EA. **\$13990**



ACCESSORIES - included

- ▶ Teflon Basket
- ▶ Rack
- ▶ Baking Stone
- ▶ Non-stick baking pad
- ▶ Paddle



Fully programmable touchscreen controls



Bonn Commercial Microwave Ovens are recognised as being Australia's market leaders in high quality Commercial Microwave Ovens.

HIGH PERFORMANCE SERIES MICROWAVES with 

The Bonn High Performance Series offer a choice of cooking power output, and market leading speed. Heavy Duty construction, high power, 200 programs and Bonn's unique *MicroSave* protection option makes these models the most advanced High Performance Commercial Microwave Oven and the number one choice amongst professionals. Utilising *Dual Magnetron* technology to reduce the operating temperature of each magnetron by up to 50% when compared to single magnetron ovens means a longer life span with greater reliability. This oven also comes with an On-Site 24 Months Parts / 13 Month Labour Warranty*.

The unique removable *MicroSave* Cavity Liner reduces service costs by up to 80% and extends the life of the oven and significantly improves hygiene by collecting all spills/spatters for easy cleaning. This patented *MicroSave* Cavity Liner is available as an optional extra, dishwasher safe and is a must for all professional users.

Bonn CM-1901T

- ▶ 1900W Microwave Output, 5 Power Levels
- ▶ 15 Amp plug single phase (Max. Draw 14.9A)
- ▶ 26 Litre Internal capacity
- ▶ Fully programmable Touch Pad with 200 Preset Memories, Digital Display
- ▶ Full Stainless Steel Interior/Exterior
- ▶ Door construction: Toughened Glass,
- ▶ Commercial quality Hinges and handle
- ▶ External Dimensions 464W x 365H x 580Dmm
- ▶ Internal Dimensions 370W x 190H x 370Dmm ▶ Weight: 32Kgs
- ▶ Optional *MicroSave* Cavity Liner for easy cleaning /maintenance.

LIST PRICE EA. **WITHOUT MICROSAVE** \$3100
 LIST PRICE EA. **WITH MICROSAVE** \$3486



CPS6A MicroSave Dishwasher Safe Cavity Liner - purchased separately :

LIST PRICE EA. \$406
 (Save \$20.00 when purchased with oven)



Shown with *MicroSave* Cavity Liner

Bonn CM-1401T

- ▶ 1400W Microwave Output, 5 Power Levels
- ▶ 10 Amp plug single phase (Max. Draw 9.9A)
- ▶ 26 Litre Internal capacity
- ▶ Fully programmable Touch Pad with 200 Preset Memories, Digital Display
- ▶ Full Stainless Steel Interior/Exterior
- ▶ Door construction: Toughened Glass, Commercial quality Hinges and handle
- ▶ External Dimensions 464W x 365H x 580Dmm
- ▶ Internal Dimensions 370W x 190H x 370Dmm
- ▶ Weight: 32Kgs
- ▶ *MicroSave* Cavity Liner for easy cleaning /maintenance.

ONLY REQUIRES 10A POWER

LIST PRICE EA. **WITHOUT MICROSAVE** \$2590
 LIST PRICE EA. **WITH MICROSAVE** \$2976



PERFORMANCE SERIES MICROWAVES

The Bonn Performance Series Microwaves offer users preset programming, ceramic base, full stainless steel construction, generous 21 litre capacity and a choice of output power.

Incorporating the latest generation high efficiency Magnetron, these models incorporate many of the design features from the Bonn High Performance Range of ovens, including Direct Ducted Magnetron cooling, motorised stirrer fan for even heating along with all the safety features such as toughened inner door glass, heavy duty door safety latches and double-strengthened door hinges - all part of Bonn's stringent total safety philosophy.

Get commercial quality and speed with ease of operation and superior Bonn quality.

Supplied with 24 Month Parts / 13 Month Labour Back to Base Warranty*

Bonn CM-1042T

- ▶ 1200W Microwave Output, 4 Power Levels
- ▶ 10 Amp plug single phase (Max. Draw 8.5A)
- ▶ 21 Litre Internal capacity
- ▶ 20 Preset Memories, Digital Display
- ▶ Full Stainless Steel Interior/Exterior
- ▶ Door construction: Toughened Glass, Commercial quality Hinges and handle
- ▶ External Dimensions 490W x 325H x 450Dmm
- ▶ Internal Dimensions 310W x 209H x 325Dmm
- ▶ Weight: 19.5Kgs

LIST PRICE EA.

\$1420



Bonn CM-1051T

- ▶ 1000W Microwave Output, 4 Power Levels
- ▶ 10 Amp plug single phase (Max. Draw 7.6A)
- ▶ 21 Litre Internal capacity
- ▶ 20 Preset Memories, Digital Display
- ▶ Full Stainless Steel Interior/Exterior
- ▶ Door construction: Toughened Glass, Commercial quality Hinges and handle
- ▶ External Dimensions 490W x 325H x 450Dmm
- ▶ Internal Dimensions 310W x 209H x 325Dmm
- ▶ Weight: 19.5Kgs

LIST PRICE EA.

\$1040



LIGHT DUTY SERIES MICROWAVES

The Bonn Light Duty Microwave Series offers the smaller users preset programming (10 presets), ceramic base, stainless steel exterior, large 25 litre capacity and 900 Watt output.

Incorporating several of the design features from the Bonn Performance Range of ovens, including motorised stirrer fan for even heating and ceramic base.

This entry level commercial oven offers ease of operation and Bonn quality.

Supplied with our exclusive 13 month Back to Base labour and parts warranty*.

Bonn CM-902T

- ▶ 900W Microwave Output, 4 Power Levels
- ▶ 10 Amp plug single phase (Max. Draw 6.5A)
- ▶ 25 Litre Internal capacity
- ▶ 10 Preset Memories, Digital Display
- ▶ Programmable 1 to 3 stage cooking
- ▶ Rugged hinges and door handle
- ▶ Stainless Steel Exterior
- ▶ Stainless Steel Interior with Ceramic base
- ▶ External Dimensions 510W x 380Dmm x 335H
- ▶ Internal Dimensions 330W x 330Dmm x 212H
- ▶ Weight: 15 Kgs

LIST PRICE EA.

\$699





MANUAL & ELECTRIC CAN OPENERS

Etlund are the industry leaders in quality, reliable can opening solutions and produce a wide range to suit any work load. Made tough with quality components, yet easy and safe to operate.

► Quality manufactured in USA ► Parts remove easily for replacement and cleaning ► Etlund blades are reversible for longer life ► Knife edges are intentionally dull and rounded to fold metal not cut it, thereby providing a smooth rim edge for greater safety.

MODEL 1

Nickel plated opener and sturdy base with standard length bar, suitable for cans up to 280mm tall.

4 cans per minute.

Recommended daily use up to 15 cans.

Overall Height: 530mm

Weight packed: 8.1Kgs

LIST PRICE EA. \$480

MEDIUM USAGE



ELECTRIC CAN OPENERS

► Effortless electric operation to eliminate fatigue ► Spring-loaded mechanism opens even dented cans ► Replaceable knife and gear provide long life ► Sleek stainless steel construction provides durable operation and easy cleaning.

266

Single Speed Electric Can Opener

4-7 cans per minute.

Recommended daily use up to 75 cans.

Most suitable for size #10 cans.

Dimensions: 111Wmm x 178Dmm x 305Hmm

Weight: 5.57Kgs

Electrical: 120W 0.5A Supplied with 10 amp plug.

LIST PRICE EA. \$2750

EFFORTLESS
MEDIUM to HIGH
USAGE



CROWN PUNCH CAN OPENERS – PNEUMATIC

610

Unit complete with knife and guard ring locator for one standard size #10 round can.

All stainless steel including mechanism.

8-12 cans per minute.

Recommended daily use up to 400 cans.

(Note: Compressor not included).

LIST PRICE EA. \$17990

HIGH
PRODUCTION



SANITATION & STORAGE

The patented KSUV-18 Knife Sterilizer Cabinet provides superior sterilization compared to other methods or products using magnetic bars or metal racks to secure the knives. The exclusive non-filtering clear slotted knife holder and special mirrored interior walls eliminate shadows on knife surfaces within the cabinet that could prevent complete sterilization. The easy to operate mechanical timer can be set for up to 15 minutes, but the KSUV-18 will safely sterilize your knives in as little as 3 minutes with 99% efficacy**. It's like a SPF-99 (Sterilization Protection Factor) for your knives.



*Note: Knives not included

- 15 minute belled timer
- Holds up to 12 knives plus steel*
- Stainless steel construction
- LED lights indicate when door is closed and sterilization is in process
- UV filtered plexiglass door with lockable keyed handle
- Exclusive non UV filtering slotted knife holder
- 2 Larger slots to accommodate cleavers
- Safety interlock door

CODE	W X D X Hmm	KG	\$
KSUV-18	483 x 150 x 610	13.7	4300

CONTACT US FOR OTHER ITEMS AVAILABLE IN THE RANGE



Heavy Duty Crown Punch Can Openers



GRANITIME GRANITA MACHINES

European design and built, fast to freeze, simple to operate and built to last.



GRANITIME Granita Machines

- Enlarged refrigeration capacity.
- Highest level of performance in the most challenging environments.
- New push and pull taps preventing product pour issues.
- Thorough and continuous product mixing.
- 12lt per bowl capacity.
- Brushed stainless steel body .
- Simple operation.
- Built strong yet simple to clean.

CODE	W X D X Hmm	KG	POWER REQUIREMENTS	WATTS	CAPACITY	\$
GRANITIME 1	200 x 480 x 820	30	10amp	800	1 x 12ltr bowl	3400
GRANITIME 2	400 x 480 x 820	55	10amp	1000	2 x 12ltr bowl	5100
GRANITIME 3	600 x 480 x 820	70	10amp	1200	3 x 12ltr bowl	6995



V-AIR

V-AIR Frozen Beverage Machine

- Defrost system 75% faster
- Electronic Density Control
- No separation needed
- Easy-to-remove filter
- Hinged Lid
- Multifunction & multilanguage display



Slush	Sherbet	Sorbet	Drinks	Frozen Cocktails	Frapuccinos	Cream
✓	✓	✓	✓	✓	✓	✓

MODEL	W X D X Hmm	KG	POWER	WATTS	CAPACITY	\$
V-AIR-2	400 x 480 x 820	56	10amp	600	2 x 12ltr bowl	7400
V-AIR-3	600 x 480 x 820	70	10amp	1000	3 x 12ltr bowl	9200
SL8AF001849	AUTO-FILL PRE-MIX SYSTEM - ONE REQUIRED FOR EACH BOWL					1980



V-DREAM

Slush	Sherbet	Sorbet	Drinks	Frozen Cocktails	Milkshakes	Frapuccinos	Cream
✓	✓	✓	✓	✓	✓	✓	✓

MODEL	W X D X Hmm	KG	POWER	WATTS	CAPACITY	\$
V-DREAM	400 x 770 x 830	99	10amp	max 2000	18L Hopper & 7L Cylinder	20980

V-DREAM

- Refrigerated hopper
- Product ready in less than 20 minutes*
- Direct drive cylinder mixer motor
- Brushless hopper mixer motor
- Modulated fan
- Multilanguage display
- Easy-to-remove filter





Hatco, the world's leaders in food warming and holding technology, continue to lead the way with high quality, reliable and aesthetically correct **Decorative Heat Lamps**. **With 14 shade styles, 24 colour and finish options, plus a choice of 10 mounting and switch locations**, there will be a model to suit your project or restaurant perfectly. Hatco Decorative Heat Lamps are perfect for enhancing your food pass/servery. Choose the lamps that the experts choose.

DECORATIVE HEAT LAMPS - IN STOCK - all others to order

DL-600-CL/BCOPPER
 Hatco Decorative Heat Lamp
 Features flexible cord mount to canopy.
 Overall length is 1829mm. (Longer length available on application).
 Black cord standard.
 Switch on lamp housing
Bright Copper plated finish.
 Supplied unplugged
LIST PRICE EA. \$1200



DL-400-CL/BOLDBLACK
 Hatco Decorative Lamp
 Features flexible cord mount to canopy.
 Overall length is 1829mm (Longer length available on application).
 Black cord standard.
 Switch on lamp housing.
Bold Black finish.
 Supplied unplugged
LIST PRICE EA. \$880



DL-500-RL-CH/BK
 Hatco Retractable Decorative Heat Lamp
 Features a cord which adjusts the lamp up and down from 762 mm to 1740 mm.
 Black cord is standard.
 Switch on lamp housing.
Glossy grey finish.
 Supplied unplugged
LIST PRICE EA. \$1430



DL-775-RPL-BN/BK
 Hatco Retractable Decorative Heat Lamp
 Features a cord which adjusts the lamp up and down from 762 mm to 1740 mm.
 Black cord is standard.
 Switch on lamp housing.
Bright Nickel finish.
 Supplied unplugged
LIST PRICE EA. \$1770



DL-500-CL-CH/BK
 Hatco Decorative Lamp
 Features flexible cord mount to canopy.
 Overall length is 1829mm (Longer length available on application).
 Black cord standard.
 Switch on lamp housing.
Glossy grey finish.
 Supplied unplugged
LIST PRICE EA. \$890



DL-750-RL/BOLDBLACK
 Hatco Retractable Decorative Heat Lamp
 Features a cord which adjusts the lamp up and down from 762 mm to 1740 mm.
 Black cord is standard.
 Switch on lamp housing.
Bold Black finish.
 Supplied unplugged
LIST PRICE EA. \$1510



All lamps supplied with 250watt Food Grade Teflon-coated heat lamp to meet Australian Food Standard regulations. (Spare Part N02.30.100.00)

Recommended height is no more than 350mm from target surface from underside of lamp.



HOW TO ORDER NON STOCK LAMPS - Contact us for a quote

1 SELECT SHADE STYLE (all 216mm Height except 1400/1500)

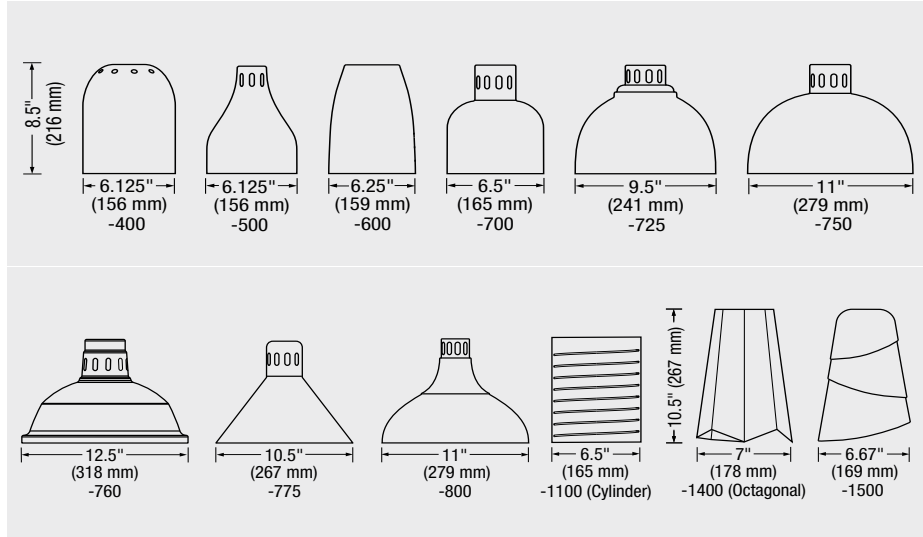

2 SELECT COLOUR/FINISH

Hatco is proud to introduce IFS **antimicrobial** powder coatings to the paint process for designer colours and gloss finishes - fighting germs to keep customers happy, healthy and **safe**.

IFS antimicrobial coatings use naturally-occurring, environmentally sustainable, silver ions to help inhibit the growth of microbes on the powder coated surface.

DESIGNER COLORS



GLOSS FINISHES



Only available for shades. Select a different option for the rest of the unit.

PLATED FINISHES

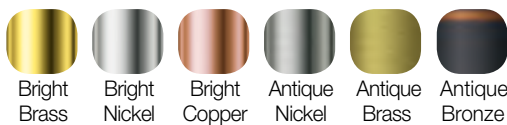

Shade color/finishes available for DL-1500 only

Select a different color or finish for the rest of the unit.



Gloss finishes, plated finishes and DL-1500 shade colors: Special process required and extended lead times

3 SELECT MOUNTING TYPE & SWITCH LOCATION

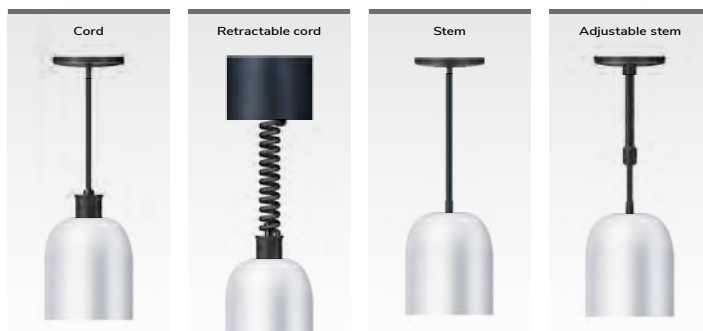

U = Upper I/O (on/off) Switch



L = Lower I/O (on/off) Switch

N = None (supplied by installer)



GLO-MAX® GM5AH CURVED INFRARED STRIP HEATERS

This stylish, patented design, based on our signature Glo-Max® strip heaters, is the perfect solution for your front-of-the-house applications. Superb for buffet and serving lines, the sleek curved design minimizes its size while accenting and warming the products below. GM5AHL, with versatile LED lighting options, provides perfect coloring and coverage while lowering energy costs.

CODE	VOLTAGE	WATTS	AMPS	DIMENSIONS	WEIGHT	\$
GM5AH-30	230 ~ 240	606 ~ 660	2.8	762W x 150D x 50Hmm	5Kg	810
GM5AHL-30	230 ~ 240	606 ~ 660	2.8		6Kg	1280
GM5AH-36	230 ~ 240	735 ~ 800	3.3	915W x 150D x 50Hmm	6Kg	865
GM5AHL-36	230 ~ 240	756 ~ 812	3.4		6Kg	1400
GM5AH-42	230 ~ 240	872 ~ 950	4.0	1067W x 150D x 50Hmm	7Kg	960
GM5AHL-42	230 ~ 240	885 ~ 964	4.0		7Kg	1670
GM5AH-48	230 ~ 240	1010 ~ 1100	4.6	1220W x 150D x 50Hmm	7Kg	1010
GM5AHL-48	230 ~ 240	1025 ~ 1116	4.7		8Kg	1670
GM5AH-54	230 ~ 240	1148 ~ 1250	5.2	1372W x 150D x 50Hmm	8Kg	1010
GM5AHL-54	230 ~ 240	1163 ~ 1267	5.3		8Kg	1810
GM5AH-66	230 ~ 240	1433 ~ 1560	6.5	1675W x 150D x 50Hmm	9Kg	1180
GM5AHL-66	230 ~ 240	1450 ~ 1579	6.6		10Kg	1890
GM5AH-78	230 ~ 240	1736 ~ 1890	7.9	1981W x 150D x 50Hmm	10Kg	1370
GM5AHL-78	230 ~ 240	1754 ~ 1910	8.0		11Kg	2530



Sleek Curved Design

Clear anodized is the standard housing color, black anodized is an option
 Angle brackets are standard, non-adjustable tubular stands, 406 mm (16"), are an option
 Warm LED light (3000K)
 Power wire lead length is 1524 mm

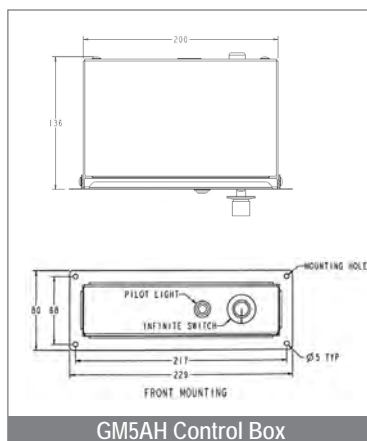

GM5AH Control Box

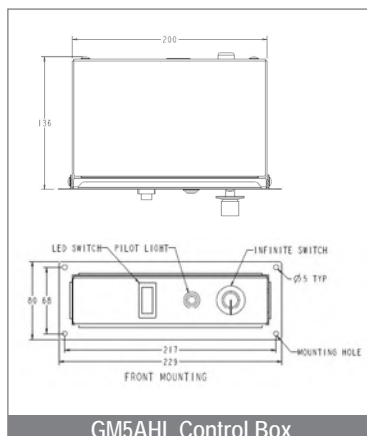

GM5AHL Control Box

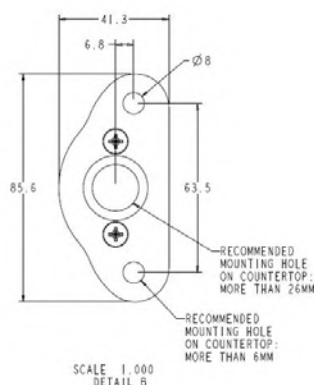
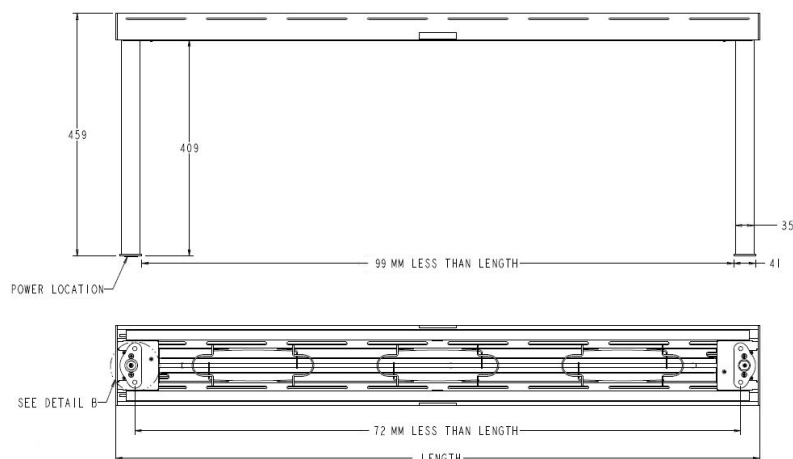



GLO-MAX® HLC5 LED CURVED DISPLAY LIGHTS

A stylish choice for illuminating your serving area. The HLC5 LED Display Light offers the highest light output that is ideal for illuminating food products with a cool white light (4000K). The sleek, curved design is patented and the LED lighting delivers significant savings with lower energy consumption and greater reliability.

CODE	VOLTAGE	WATTS	AMPS	WEIGHT	DIMENSIONS	DESCRIPTION	\$
HLC5-30	220 - 240	11	0.05	4kg	762 x 150 x 50 mm		980
HLC5-36	220 - 240	14	0.06	4kg	915 x 150 x 50 mm		1020
HLC5-42	220 - 240	15-16	0.07	5kg	1067 x 150 x 50 mm	Housing color: standard clear anodized or optional black anodized	1070
HLC5-48	220 - 240	17	0.08	6kg	1220 x 150 x 50 mm	LED light color: cool white (400K)	1110
HLC5-54	220 - 240	19	0.08	7kg	1372 x 150 x 50 mm	Mounting options: standard angle brackets or optional 406 mm non-adjustable tubular	1220
HLC5-66	220 - 240	22	0.09-0.1	8kg	1675 x 150 x 50 mm	Rocket Switch, location: under unit on power side	1335
HLC5-78	220 - 240	24	0.1-0.11	8kg	1981 x 150 x 50 mm	Power wire lead length: 1524mm	1506

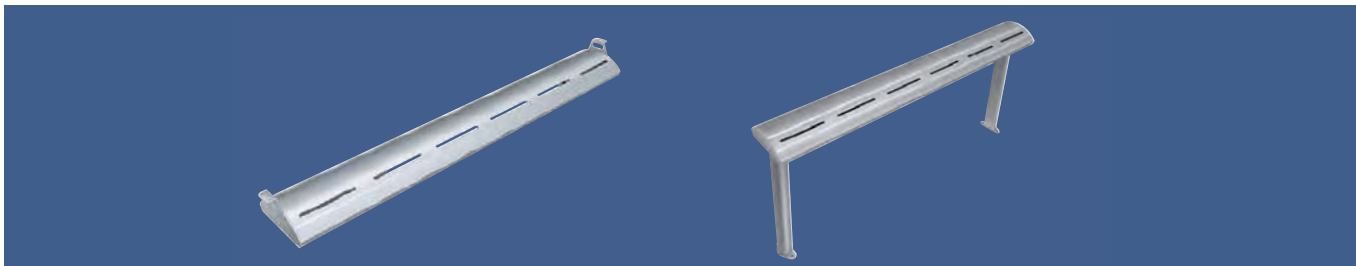

Shown on optional stand.

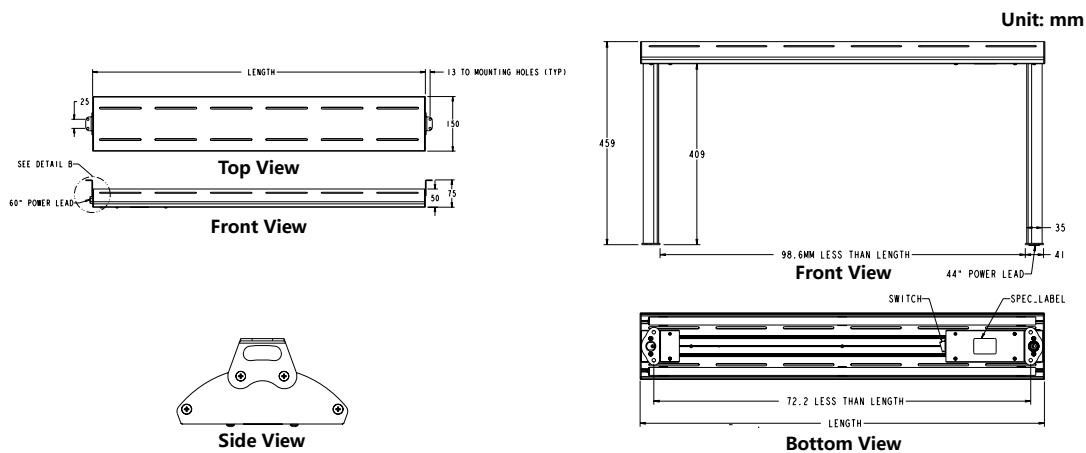



Acknowledged world leaders in food holding and warming solutions, Hatco offer a breadth of products and solutions that answer almost any heating/warming/holding requirement.

And Hatco lead the way in merchandising solutions with high quality - high visibility products. Call to discuss your special requirements or project needs - Hatco has a quality solution and Hatco products are covered by our exclusive 13 month warranty on parts and labour.

GLO RAY FOOD WARMER GRAH Heat only

Sturdy cast aluminium housing with patented metal sheathed heating rods and designed heat deflectors to control heat pattern (See schematic below). Safety wire guards, mounting brackets and 1800mm cord with 10A plug standard. All units 150mmW x 64mmH

MODEL	\$	LENGTH	WATTAGE	MODEL-IC	LENGTH	\$
GRAH-18	680	460mm	350W	GRAH-18-IC	460mm	850
GRAH-24	715	610mm	500W	GRAH-24-IC	610mm	885
GRAH-30	755	760mm	660W	GRAH-30-IC	760mm	930
GRAH-36	795	910mm	800W	GRAH-36-IC	910mm	965
GRAH-42	845	1070mm	950W	GRAH-42-IC	1070mm	1015
GRAH-48	885	1220mm	1100W	GRAH-48-IC	1220mm	1055
GRAH-54	940	1370mm	1250W	GRAH-54-IC	1370mm	1110
GRAH-60	995	1520mm	1400W	GRAH-60-IC	1520mm	1165
GRAH-66	1080	1680mm	1560W	GRAH-66-IC	1680mm	1250
GRAH-72	1210	1830mm	1725W	GRAH-72-IC	1830mm	1380
GRAH-84	1385	2130mm	1900W	GRAH-84-IC	2130mm	1560
GRAH-96	1565	2440mm	2400W	GRAH-96-IC	2440mm	1735



FOR INFINITE CONTROL MODELS SEE "IC" COLUMN ←

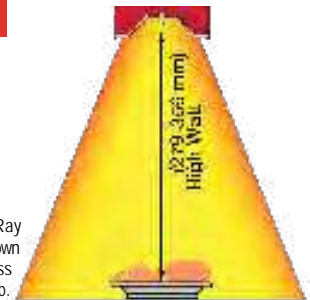

Typical Glo Ray installation shown above stainless steel benchtop.

GLO RAY FOOD WARMER GRAHL Heat & Light

Sturdy cast aluminium housing with patented metal sheathed heating rods and designed heat deflectors to control heat pattern. Includes Incandescent lighting, safety wire guards, mounting brackets and 1800mm cord with 10A or 15A* plug standard. All units 230mmW x 64mmH

MODEL	\$	LENGTH	WATTAGE	MODEL-IC	LENGTH	\$
GRAHL-18	935	460mm	470W	GRAHL-18-IC	460mm	1105
GRAHL-24	965	610mm	620W	GRAHL-24-IC	610mm	1140
GRAHL-30	1080	760mm	780W	GRAHL-30-IC	760mm	1250
GRAHL-36	1215	910mm	980W	GRAHL-36-IC	910mm	1385
GRAHL-42	1285	1070mm	1130W	GRAHL-42-IC	1070mm	1455
GRAHL-48	1435	1220mm	1340W	GRAHL-48-IC	1220mm	1605
GRAHL-54	1540	1370mm	1490W	GRAHL-54-IC	1370mm	1710
GRAHL-60	1715	1520mm	1700W	GRAHL-60-IC	1520mm	1890
GRAHL-66	1845	1680mm	1860W	GRAHL-66-IC	1680mm	2020
GRAHL-72	2095	1830mm	2085W	GRAHL-72-IC	1830mm	2265
GRAHL-84	2460	2130mm	2470W* 15A	GRAHL-84-IC	2130mm	2635
GRAHL-96	2700	2440mm	2880W* 15A	GRAHL-96-IC	2440mm	2870

FOR INFINITE CONTROL MODELS SEE "IC" COLUMN ←

REMOTE CONTROLS & IC UNITS

Use 1 Infinite Control per Glo Ray element

MODEL	DESCRIPTION	\$
RMB-3CE	Remote Control Enclosure with 1 Infinite Control	360
RMB-7CE	Remote Control Enclosure with 2 Infinite Controls	495



RMB-3CE



Dual Remote Control RMB-7CE

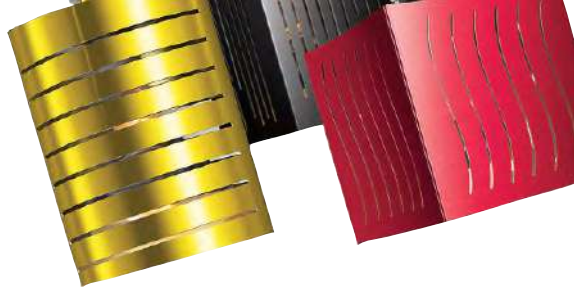

Hatco heated shelves are the benchmark for quality, reliability and style when it comes to holding food at serving temperatures.

Choose from portable table-top models, drop-in or flush mount models to suit any project or venue requirement, and serve with style and practicality.

HEATED BLACK GLASS PORTABLE SHELVES 400mm DEEP

HGSM-4060

Hatco's Heated Glass Shelf Modular units feature black ceramic glass to create uniform heat across the entire surface to hold hot food at safe-serving temperatures for longer without affecting product quality.

Modular design allows for multiple units to be placed side-by-side and for easy cleaning and maintenance.

Includes thermostatic controls with five temperature settings of 55°C, 65°C, 75°C, 85°C and 95°C. Touch Panel Control.

Constructed with a durable stainless steel housing.

Weight: 7.5Kgs Dimensions: 400W X 600D X 56Hmm

Electrical: 300 Watts, 1.3 amp. supplied with corded 10amp plug.

LIST PRICE EA. \$1385



GLO-RAY® GRS PORTABLE HEATED SHELF 495mm DEEP

Convenient portable heated shelf units 495mm 'deep', that offer the flexibility of use when and where needed. Hatco's unique blanket element design provides even temperature across the shelf for extended product serving/holding times.

Temperature Range: 27-82°C. Designer colours to order.

CODE	DIMENSIONS	WATTS	WEIGHT	\$
GRS-24-I	610 mm long x 495 mm wide	380	10Kg	1975
GRS-30-I	762 mm long x 495 mm wide	490	12Kg	2125
GRS-36-I	914 mm long x 495 mm wide	598	13Kg	2270
GRS-42-I	1067 mm long x 495 mm wide	652	15Kg	2555
GRS-48-I	1219 mm long x 495 mm wide	760	17Kg	2660
GRS-54-I	1372 mm long x 495 mm wide	870	20Kg	2860

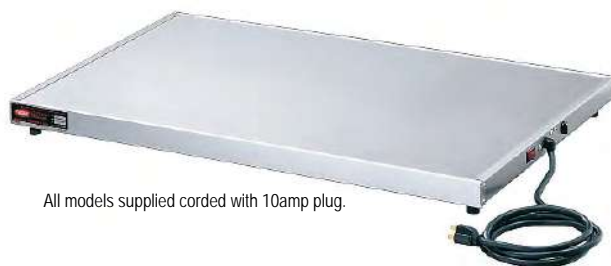

All models supplied corded with 10amp plug.



Shown with optional pan guards.

GLO-RAY® GRS-D PORTABLE HEATED SHELF 305mm DEEP

Convenient portable heated shelf units 305mm 'deep' models, perfect for burger or product make-up and holding on the one bench space. Hatco's unique blanket element design provides even temperature across the shelf for extended product serving/holding times. Designer colours to order.

CODE	DIMENSIONS	WATTS	WEIGHT	\$
GRS-60-D	1524 mm long x 305 mm wide	600	16Kg	2365
GRS-72-D	1829 mm long x 305 mm wide	700	17Kg	2455



All the above supplied corded with 10amp plug.

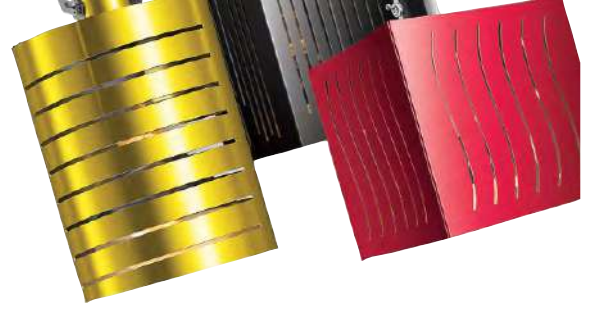

GLO-RAY® GRSBF DROP-IN FLUSH TOP HEATED SHELF

Satin Black hard coated aluminium finish with flush mount, for a smooth professional finish, includes remote temperature control and ON/OFF switch.

Ideal for use on pass-through areas, buffet lines and as hors d'oeuvre displays. They feature a thermostatically-controlled blanket-type foil element heated surface to help hold your food hot and delicious with consistent temperatures across the shelf. Adjustable thermostat controls allow surface temperature for the GRSBF to range from 27° to 82°C.

CODE	DIMENSIONS (all 60mm height)	WATTS	WEIGHT	\$
GRSBF-24-I	648mm long x 533 mm wide	550	13Kg	3270
GRSBF-30-I	800 mm long x 533 mm wide	665	14Kg	3455
GRSBF-36-I	953 mm long x 533 mm wide	780	14Kg	3700
GRSBF-42-I	1105 mm long x 533 mm wide	885	15Kg	3890
GRSBF-48-I	1257 mm long x 533 mm wide	1000	18Kg	3770
GRSBF-54-I	1372 mm long x 533 mm wide	1220	22Kg	4300
GRSBF-60-I	1562 mm long x 533 mm wide	1220	22Kg	4500
GRSBF-72-I	1867 mm long x 533 mm wide	1440	24Kg	4860



All the above supplied corded with 10amp plug.

Please note: depths/widths other than 533mm available on request: 432, 648, 800mm.

GLO-RAY® HBGB DROP-IN HEATED BLACK CERAMIC GLASS SHELF

For a dramatic and professional food serving area, the Hatco Heated Black Glass Shelf has a heated ceramic glass surface to create uniform heat across the entire surface and display food perfectly.

Ideal for use on pass-through areas, buffet lines and as hors d'oeuvre displays. Surface colour is black ceramic glass and they feature a thermostatically-controlled heated ceramic glass surface to help hold your food hot and delicious. Food can be placed directly on the glass surface. Supplied with an attached stainless steel trim mounting ring for drop in installations.

Adjustable thermostat controls allow surface temperature for the HBGB to range from 38° to 82°C. Recommended for installation in metallic surfaces.

CODE	DIMENSIONS* (all 55mm Height)	WATTS	WEIGHT	\$
HBGB-2418	651 mm long x 498 mm wide	425	15Kg	5230
HBGB-3018	803 mm long x 498 mm wide	525	17Kg	5455
HBGB-3618	955 mm long x 498 mm wide	630	19Kg	5670
HBGB-4818	1260 mm long x 498 mm wide	850	23Kg	6220
HBGB-6018	1565 mm long x mm 498 wide	1050	29Kg	6640
HBGB-7218	1870 mm long x 498 mm wide	1260	34Kg	7120



* Outer dimensions of the stainless steel trim. All the above supplied corded with 10amp plug. Controller dimensions 178 x 76mm. Note: HBGB Units over 955 mm are constructed of two equal size pieces of glass. Recommended for use in a metallic countertop. For other surfaces, verify that the material is suitable for temperatures up to 94°C.





HATCO HOT OR COLD SHELF

Serve hot buffet or cool salads/sweets on the same shelf space easily and quickly with flexibility to suit your venue. These units come in traditional Hardcoat finish or Swanstone® Simulated Stone Finish to match any decor, available as a Drop-In Flush mount. Save space and maximise the space you already have.

From the world-wide leaders in food holding solutions this versatile shelf satisfies your differing serving needs at the touch of a button. Patent-pending thermal break technology and renowned Hatco reliability - Hot OR Cold and now available Cold Only.

- ▶ Easily change between Hot or Cold in under an hour (approx) to suit your needs
- ▶ **Temperature Range:** -12°C to 82°C
- ▶ Control Box can be remotely mounted up to 1229mm from centre of the shelf
- ▶ Maximise the usage of your available space for hot or cold servings
- ▶ Durable Hardcoat Aluminium Finish Drop-In Flush Mount or...
- ▶ *Swanstone®* food safe simulated stone colours available to match your decor and other Hatco Heated Shelves
- ▶ Famous Hatco performance and reliability
- ▶ Patent-pending thermal break reduces condensation and temperature transfer.
- ▶ Includes a remote-mountable control enclosure, with a three position power switch and two digital temperature controllers.

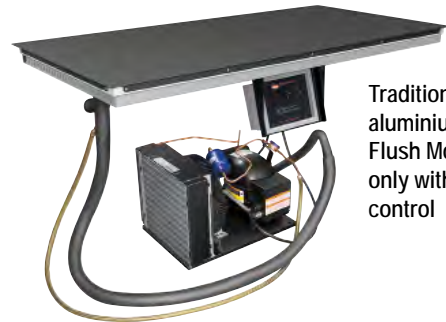

Traditional hard coat aluminium drop-in Flush Mount Cold only with remote control



Swanstone® Granite Gray simulated stone drop-in Flush Mount Hot or Cold with remote control



Hot or Cold Remote control with three position switch and two electronic temperature controls

Stone Colours



Gray Granite



Bermuda Sand



Night Sky

*Swanstone Colour must be specified at time of order.

Available as a Cold Only shelf.

Hatco's CSBF Cold Shelf Built-In Flush Top is a foodsafe shelf that is designed to keep pre-chilled food products in the perfect chill zone for serving. Features patent-pending thermal break that reduces condensation. Includes a power On/Off switch and digital temperature controller. Has a hardcoat aluminum surface and is designed to be top mounted.

CODE	DESCRIPTION	DIMENSIONS: (heated-cooled/overall)	Watts / Amps	Compressor	Weight	\$
HCSBF-24-I	Drop-In Hot / Cold Shelf - Hardcoat	610W x 495mmD / 648W x 533mmD	804 / 3.5	1/4HP	58Kg	14850
HCSBF-36-I	Drop-In Hot / Cold Shelf - Hardcoat	914W x 495mmD / 953W x 533mmD	1044 / 4.5	1/3HP	68Kg	15230
HCSBF-48-I	Drop-In Hot / Cold Shelf - Hardcoat	1219W x 495mmD / 1257W x 533mmD	1044 / 4.5	1/3HP	84Kg	16970
HCSSBF-24-I	Drop-In Hot / Cold Shelf - Swanstone*	610W x 495mmD	804 / 3.5	1/4HP	67Kg	15230
HCSSBF-36-I	Drop-In Hot / Cold Shelf - Swanstone*	914W x 495mmD	1044 / 4.5	1/3HP	76Kg	15700
HCSSBF-48-I	Drop-In Hot / Cold Shelf - Swanstone*	1219W x 495mmD	1044 / 4.5	1/3HP	92Kg	17280
CSBF-24-I	Drop-In Cold Shelf - Hardcoat	610W x 495mmD / 648W x 533mmD	816/3.5	1/3HP	53KG	12800
CSBF-36-I	Drop-In Cold Shelf - Hardcoat	914W x 495mmD / 953W x 533mmD	816/3.5	1/3HP	62Kg	13015
CSBF-48-I	Drop-In Cold Shelf - Hardcoat	1219W x 495mmD / 1257W x 533mmD	816/3.5	1/3HP	71Kg	14580



HATCO® DROP-IN SLIM FROST TOP

Convenience meets style with the Hatco Drop-In Slim Frost Tops. Perfect for quick turn products on self-serve buffets. Save space and maximise the space you already have.

Hatco Drop-in Slim Frost Tops keep pre-chilled beverages, snacks, hors d'oeuvres and side dishes cool and ready to serve. Slim configuration provides wider access to your customers.

- ▶ Available in 2- and 3-pan slim configurations
- ▶ NSF 7 approved cold wall construction utilizes a refrigerant that keeps food product cold without drying it out
- ▶ Auto-defrost is activated through an advanced programmable electronic controller
- ▶ Matches the Hatco line of Heated Wells for an integrated look
- ▶ The condensing unit, mounted on the centre of the unit, rotates 180° (movable in some models)
- ▶ Long, flexible refrigerant line (ability to pull out condensing unit) for service
- ▶ Famous Hatco performance and reliability



FTB-S2 Drop-In Slim Frost Top

CODE	DESCRIPTION	DIMENSIONS: (heated-cooled/overall)	Watts / Amps	Compressor	Weight	\$
FTB-S2	Drop-In Slim Frost- Top	1395W x 535D x 437Hmm	804 / 6.7	1/4HP	83Kg	14800
FTB-S3	Drop-In Slim Frost- Top	2053W x 535D x 437Hmm	804 / 6.7	1/4HP	108Kg	16525

HATCO® COLD UNDERMOUNT SHELF

Hatco's CSU Cold Undermount Shelf is a foodsafe shelf that is designed to keep pre-chilled food products in the perfect chill zone for serving.

- Undermount shelves have the amazing benefit of being able to be installed under the counter top of your choice***
- Long, flexible refrigerant line (ability to pull out condensing unit) for service
- Electronic Temperature Control Box with a 1219 mm lead wire
- Anodized aluminum surface

***Approved materials include granite and quartz up to 30 mm, Swanstone® (provided by Hatco), and certain stainless steel or aluminum surfaces approved by Hatco. Please contact FSM for applications with other material



CODE	DESCRIPTION	DIMENSIONS:	Watts / Amps	Compressor	Weight	\$
CSU-24-I	Cold Undermount Shelf	697W x 579D x 257Hmm	1296 / 5.4	1/3HP	52Kg	12530
CSU-36-I	Cold Undermount Shelf	998W x 579D x 257Hmm	984 / 4.1	3/8HP	64Kg	12600
CSU-48-I	Cold Undermount Shelf	1303W x 579D x 257Hmm	984 / 4.1	3/8HP	70kg	13825



GLO-RAY® HEATED DISPLAY WARMERS

Boost impulse sales by showcasing your hot foods in the Hatco Glo-Ray merchandising warmers. Designed specifically for displaying wrapped or boxed product, these warmers hold hot food safely at proper serving temperatures and are seen in many of the best known venues around the world.

- ▶ Pre-focused infrared top heat directs heat to the outer edges where heat loss is greatest
- ▶ Convenient for self-serve or quick-serve areas
- ▶ Available in two-tier models with horizontal or slanted shelves
- ▶ Adjustable product divider rods sort food displays for convenience and product appeal
- ▶ Thermostatically controlled hard-coated heated base extends holding times
- ▶ Food grade Teflon coated incandescent lights illuminate the holding areas and product for maximum visibility.

GRSDS *Slant* Model - all 617 mm deep

CODE	DESCRIPTION	KW	AMP	WEIGHT	\$
GRSDS-24D	Dual Shelf - 610 mmW	1.34kw	5.6 amp	52Kg	9770
GRSDS-30D	Dual Shelf - 760 mmW	1.53kw	6.4 amp	64Kg	10310
GRSDS-36D	Dual Shelf - 910 mmW	1.81kw	7.6 amp	73Kg	11020
GRSDS-41D	Dual Shelf - 1040 mmW	2.12kw	8.8 amp	82Kg	11825
GRSDS-52D*	Dual Shelf - 1320 mmW	2.73kw	11.4 amp	98Kg	13735
GRSDS-60D*	Dual Shelf - 1520 mmW	3.34kw	14 amp	108Kg	14580

Units 24D - 41D supplied corded with 10A plug.
*Units 52D - 60D supplied corded with 15A plug.



GR2SDS *Slant* Model DESIGNER SERIES - All 677 mm deep

CODE	DESCRIPTION	KW	AMP	WEIGHT	\$
GR2SDS-24D	Dual Shelf - 770 mmW	1.64kw	6.9 amp	73Kg	11555
GR2SDS-30D	Dual Shelf - 920 mmW	2.04kw	8.5 amp	84Kg	12370
GR2SDS-36D*	Dual Shelf - 1070 mmW	2.44kw	10.2 amp	91Kg	13175
GR2SDS-42D*	Dual Shelf - 1220 mmW	2.98kw	12.5 amp	99Kg	14365
GR2SDS-48D*	Dual Shelf - 1380 mmW	3.38kw	14.1 amp	116Kg	15550
GR2SDS-54D^	Dual Shelf - 1530 mmW	3.78kw	15.8 amp	120Kg	16740
GR2SDS-60D^	Dual Shelf - 1680 mmW	4.42kw	18.4 amp	135Kg	17930

Units 24D - 30D supplied corded with 10A plug.
*Units 36D - 48D supplied corded with 15A plug. ^Units 54D - 60D supplied unplugged.

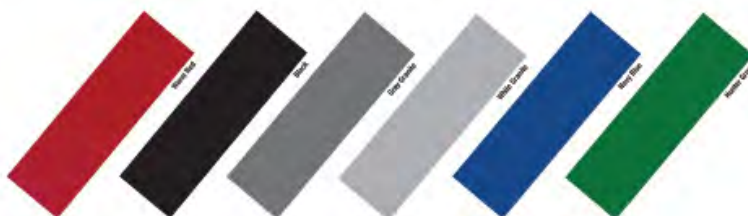

Horizontal models also available to order. Please specify colour at time of ordering, otherwise colour inserts and cap ends will be supplied in black.



GLO-RAY® 2-GO HEATED SHELVES

Hatco's GRS2G Glo-Ray 2-Go™ Heated Shelf, designed specifically with delivery and carry-out needs in mind, is capable of holding a great quantity of hot food items at optimum serving temperatures.

- Holds bags and boxes of food for up to 30 minutes with a high temperature range up to 93°C.
- Touchscreen control with digital readout indicates separate heat and timer for each shelf.
- Features shelves with heated bases that are thermostatically-controlled and has a stainless steel frame.
- The cord is recessed into the bottom shelf at a 45° angle, allowing the unit to be flush against the wall.



GRS2G-3920-4 shown

CODE	DESCRIPTION	DIMENSIONS:	Watts / Amps	Weight	\$
GRS2G-3920-2	2 Heated shelves	1093W x 508D x 546Hmm	766 / 3.2	69Kg	6156
GRS2G-3920-3	3 Heated shelves	1093W x 508D x 908Hmm	1148 / 4.8	80Kg	7690
GRS2G-3920-4	4 Heated shelves	1903W x 508D x 1270Hmm	1529 / 6.4	91kg	9225

Optional side and back panels are one panel per shelf, giving you the flexibility to customize your unit.

CODE	DESCRIPTION	\$
CONTROL-GRS2G-R	Controls and permanent panel on ride side in leaiu of standard left side	No charge
SPANEL-GRS2G2	Side Panel for GRS2G-3920-2	180
SPANEL-GRS2G3	Side Panel for GRS2G-3920-3	360
SPANEL-GRS2G4	Side Panel for GRS2G-3920-4	522
BPANEL-GRS2G2	Back Panel for GRS2G-3920-2	151
BPANEL-GRS2G3	Back Panel for GRS2G-3920-3	302
BPANEL-GRS2G4	Back Panel for GRS2G-3920-4	447



GRS2G-3920-3 with optional side panel (SPANEL-GRS2G3)



GLO-RAY® PORTABLE FOOD WARMERS/CHIP DUMPS

With heat from above, below or both, Hatco Glo Ray® food warmers offer design flexibility without sacrificing food product quality. Ideal for use next to fry stations, drive-through windows, and service areas that require frequent and easy access, these units keep product at serving temperature and optimum quality.

GR-FFB

This excellent Food Warmer/Chip Dump has a preset heated base that conducts heat from the bottom while an adjustable infrared element heats from above.

A swing-away top provides fast and easy access to food pans.

Weight: 12Kgs

Dimensions: 324 x 610 x 508mm

Electrical: 750 Watts, 3 amp. supplied with corded 10amp plug.

LIST PRICE EA. **\$1890**



GMFFL

Hatco's latest Portable Food Warmer has a sleek rounded design and its black colour finish fits into any decor. This portable Food Warmer has heat and light from above in powder-coat black and comes with a sign holder on the front lower panel (sign not included) to maximise sales potential.

Suits 1/1 Gastronorm pan 100mm deep (not included).

Weight: 9.2Kgs

Dimensions: 329 x 644 x 445mm

Electrical: 610 Watts, 2.5 amp supplied with corded 10amp plug.

LIST PRICE EA. **\$735**





GLO-RAY® PORTABLE FRY STATIONS & MULTI PRODUCT

Designed with ample handling space between the heat source and the holding area to empty baskets, Glo-Ray Fry Holding Stations maintain 'just made' food temperatures. Ceramic elements direct radiant heat from above, while a preset thermostatically controlled heated base (adjustable on the MPWS-36) maintains uniform holding temperature from below. The slotted holding bin allows the rising heat to envelop the food, preventing soggy product. A sectional divider permits holding of multiple products simultaneously.

A range of options are available to customise each model to suit your own operation. Call your FSM representative.

GRFHS-21

Glo-Ray Portable Fry Station
Dimensions 540 x 700 x 550mm
Weight: 30Kgs
Electrical: 1200watts, 5 amp.
Supplied corded with a 10amp plug.

LIST PRICE EA. \$6360



Shown With Optional Fry Ribbon

MPWS-36 with MPWS-36 BIN

Glo-Ray Multi-Product Warming Station – the ultimate in hot fried food holding with six thermostatically controlled high power overhead ceramic heating elements and base element complemented by food grade teflon coated incandescent lamps for enhanced product display.

Choose from a wide range of optional extras including pleated ribbons, angled risers, bag and tong holders and fry bin inserts to customise the warming station for your operation. Unit comes standard with MPWS-36BIN accessory (Full Fry Bin insert; drip tray, perforated insert, three dividers) and detachable side panel insert for left or right installations.

Dimensions: 947 x 626 x 832mm
Weight: 79Kgs
Electrical: 3075watts, 13 amp.
Supplied corded with 15amp plug.

LIST PRICE EA. \$9885



Shown With Optional Scoop Holder



HIGH WATT 4 SLOT POP-UP TOASTER 1 OR 2 SIDED TOASTING!

TPT-230-4-10 up to 160 toast slices per hour
Perfect for self-serve areas, care facilities and light-medium volume applications.

The Hatco Pop-Up Toaster provides even golden toasting of a variety of bread products.

- ▶ Durable stainless steel housing
- ▶ Four self-centering slots (32mmW)
- ▶ Two toasting controls with bagel/bun button for one-sided toasting
- ▶ Removable crumb tray.
- ▶ Two separate toasting controls

This productive and versatile unit enables the toasting of two lots of two slices of bread individually or together.

Electrical: 2.25Kw, 9.5 amps. Supplied with 10amp plug.

Dimensions: 378 x 330 x 235 mm

Weight: 8Kgs

LIST PRICE EA. \$1040



PopUp Toaster with either two lots of two or four slices toasted simultaneously.

TOAST-MAX CONVEYOR TOASTER

The Hatco Toast-Max entry-level conveyor toaster offers the flexibility and performance to perfectly toast bread and buns fast. Utilising conveyor speed, not temperature, to determine toasting colour, this allows for instant adjustment of toasting time to maintain quality.

TM-10H up to 6 slices/minute

- ▶ 4 position toast selector switch:
- ▶ off / toast / buns / standby mode.
- ▶ 89mm clearance to accommodate high profile bread products.
- ▶ easy-to-load rack with front or rear discharging.
- ▶ V-shaped reflectors help capture and redirect heat.
- ▶ Long lasting serpentine metal sheathed heating elements.
- ▶ 102mm adjustable legs.
- ▶ Pilot light signals unit is in operation.

Discharge & crumb trays are removable.

Electrical: 1900watts, 8 amps. Supplied with 10amp plug.

Dimensions: 368 x 387 x 419 mm

Shipping weight: 19Kgs

LIST PRICE EA. \$2130





TQ SERIES HIGH WATT CONVEYOR TOASTERS

The Hatco High Watt Conveyor toasters toast high moisture content bread product to a rich golden colour. Sheathed heating elements are featured in all models. Toast-Qwik models have a conveyor feed guide and front or rear discharge with toast tray.

This provides the flexibility and performance to perfectly toast bread products. The exclusive *ColorGuard® sensing system* monitors cabinet temperature and adjusts conveyor speed during high usage periods to assure uniform toast, improving customer satisfaction and reducing waste.

Power save mode conserves energy and saves money and the insulation and interior fan provide cooler surface temperatures.

TQ3-500H TOAST-QWIK

up to 500 toast slices/hour

Touch screen controller - easy to see and use

Twelve programmable settings

USB port for software updates. Black finish standard.

Programmable power save function.

Unique toast delivery rack moves toast to the storage tray each and every time.

Suitable for front discharge with tray extended.

Exclusive *Colorguard* system controls toast quality Toasts bread, buns, muffins and sandwiches.

Electrical: 2.22 kW, 9.3A. Supplied corded with 10 amp plug.

Dimensions: 373W x 524D x 435H mm

Delivery tray extends to 591 mm total depth

Height of opening 76mm

Weight: 25Kgs

LIST PRICE EA. \$5560

DIGITAL PROGRAMMABLE MODEL
With Touch Screen control and Exclusive *Colorguard* technology maintains toast colour



TQ-805 TOAST-QWIK

up to 600 toast slices/Hour

Suitable for front or rear discharge.

Exclusive *Colorguard* system controls toast quality Toasts bread, buns, muffins and sandwiches.

Electrical: 3.6 kW, 15A. Supplied corded with 15 amp plug.

Dimensions: 368W x 578D x 422H mm

Weight: 28Kgs

Includes tray extensions.

Rear tray extends 165 mm.

LIST PRICE EA. \$6590

Exclusive *Colorguard* technology maintains toast colour



TQ2-SECURITY COVER

Hinged Control Cover to suit TQ-805 units, can be retro fitted.

LIST PRICE EA. \$235



Optional TQ2-Security Cover for TQ805 Model Toaster



TQ SERIES HIGH WATT CONVEYOR TOASTERS

TQ-1800H TOAST-QWIK

up to 1200 toast slices/hour

- ▶ Suitable for front or rear discharge.
- ▶ Exclusive **Colorgard**® system controls toast quality by constantly monitoring toasting chamber temperatures and adjusting conveyor speed automatically.
- ▶ Toasts bread, buns, muffins and sandwiches.
- ▶ Adjustable Upper & Lower Heating Elements,
- ▶ Power-Save Mode,
- ▶ 367mm WIDE throat

Electrical: 4.65 kW, 20 amp. Supplied unplugged.

Dimensions - 470 x 578 x 422mm

Includes tray extensions.

Rear tray extends 165 mm

Shipping Weight 33Kg

LIST PRICE EA. \$7415

MASSIVE PERFORMANCE with Exclusive Colorguard technology that maintains toast colour



TQ Series Conveyor Toasters provide total control of the toasting of bread products. Individual controls are provided for top heat, bottom heat, conveyor speed and a stand-by switch to maximise quality and throughput. Colorgard sensing technology maintains toast quality through quiet or busy serving times. For those situations where you need to avoid patrons adjusting these controls unnecessarily, choose the TQ2 Security Cover for the TQ-805 Model.

The exclusive **ColorGuard**® sensing system monitors cabinet temperature and adjusts conveyor speed during high usage periods to assure uniform toast, improving customer satisfaction and reducing waste.





GLO-RAY® DECORATIVE CARVING STATIONS

The Glo-Ray Decorative Carving Stations are the ideal way to display, hold and serve food and to extend food holding times during serving periods. With a wide range of options and styles, Hatco have a unit that will complement your servery and decor perfectly with reliable quality.

DCS400-1-BN

Freestanding overhead height adjustable heat lamp supported by a sturdy 203mm square base.

527D x Variable Height 864-1168Hmm

Shown in Bright Nickel.

Also available in *Bright Brass and Antique Bronze*.

Weight: 15Kg

Supplied corded with 10amp plug. 250watts 1 Amp.

LIST PRICE EA. \$3235



DCSB400-2420-1-NSBN

Overhead height adjustable heat lamp supported by a rectangular Swanstone heated base with sneeze guard.

608W x 506D x Height 864 - 1168Hmm.

Shown in Night Sky Base with Bright Nickel posts and lamp.

Also available in *Bright Brass/Antique Bronze post and lamp and Gray Granite/Bermuda Sand decorative base stone colours*.

Weight: 48Kg

Supplied corded with 10 amp plug. 750watts / 3.2 Amp.

LIST PRICE EA. \$7755



DCSB400-3624-2-GGBN

Dual overhead heat lamps - height adjustable, supported by a rectangular Swanstone heated base with sneeze guard.

911W x 610D x Height 864 - 1168Hmm.

Shown in Bright Nickel post and lamp and Gray Granite base.

Also available in *Antique Bronze/Bright Brass post and lamp and Bermuda Sand/Night Sky decorative base stone colours*.

Weight: 70Kg

Supplied corded with 10 amp plug. 1300watts / 5.5Amp.

LIST PRICE EA. \$11340



COLOUR SWATCHES



Plated Colours:

Bright Nickel, Bright Brass and Antique Bronze



Stone Colours:

Gray Granite, Bermuda Sand and Night Sky



HATCO FREE STANDING DRAWER WARMERS

Available in 1, 2 & 3 drawer freestanding models built of rugged stainless steel with durable nylon drawer rollers, 12-gauge stainless steel slides and heavy-duty hardware in **Standard** or **Narrow** model to suit your kitchen space. **Unique features include:**

- ▶ ALL drawers have an **individual on/off switch**, **digital** thermostatic control, **digital** temperature monitor and adjustable sliding vents for humidity control providing superior quality control and versatility.
- ▶ Each drawer has the capacity to accept a pan 1/1x150mm deep or 2x1/2 or 3x1/3. (Pans not included).
- ▶ Supplied with **102mm legs**, 1829mm cord and 10A plug. Castor option available on ALL models.

HDW-1
 1-drawer model with Digital Control
 749W x 575D x 279Hmm (excluding legs)
 Supplied with cord and 10 amp plug.
 450watts / 2 Amp. Weight: 44Kg
LIST PRICE EA. \$5380



HDW-2
 2-drawer model with Digital Control
 749W x 575D x 537Hmm (excluding legs)
 Supplied with cord and 10 amp plug.
 900watts 3.8 Amp. Weight: 76Kg
LIST PRICE EA. \$9000



HDW-3
 3-drawer model with Digital Control
 749W x 575D x 794Hmm (excluding legs)
 Supplied with cord and 10 amp plug.
 1350watts / 5.7 Amp. Weight: 106Kg
LIST PRICE EA. \$12635



HDW-CASTER-2
Option All Models
 Hatco Heavy Duty Castor kit,
 51mm Diameter
 Add mobility to your drawer warmer with the Hatco **HDW-CASTER-2** option. These castors easily change-over with the standard legs, enabling moving for routine cleaning/ maintenance etc. (PACK OF 4)
LIST PRICE EA. \$511



HATCO FREE STANDING NARROW DRAWER WARMERS

HDW-1N Digital Control
 1-drawer Narrow model
 530W x 686D x 279Hmm (excluding legs)
 Supplied corded with 10 amp plug.
 450watts / 2 Amp. Weight: 44Kg
LIST PRICE EA. \$5380



HDW-2N Digital Control
 2-drawer Narrow model
 530W x 686D x 537Hmm (excluding legs)
 Supplied corded with 10 amp plug.
 900watts / 3.8 Amp Weight: 76Kg
LIST PRICE EA. \$9000





HATCO FREE STANDING DRAWER WARMER

Available in 1, 2 & 3 drawer freestanding models built of rugged stainless steel with durable nylon drawer rollers. **Unique features include:**

- Top-of-the-unit Touchscreen Controller is positioned at an angle for greater visibility
- Controller allows individual temperature control and hold timer per drawer with both visual and audio alerts
- Robust stainless steel construction inside and out.
- Easy-to-clean seamless, interior core with snap out out side panels make this unit easy to service
- Each drawer has adjustable vents for varying moisture levels in individual drawers
- Drawer frame can accommodate varying pan configurations, including 1/1 GN, 1/3 GN, 1/3 GN up to 152 mm deep, with or without lids.

HDWTC-2

2-drawer model
 622W x 650D x 573Hmm
 Supplied on 51mm Castors
 Add 38mm to depth for door handles
 Supplied with cord and 10 amp plug.
 766watts / 3.2 Amp. Weight: 81Kg

LIST PRICE EA. \$10790



HATCO DRAWERMAX® DRAWER WARMERS

2 drawer freestanding model built with rugged construction and heavy-duty hardware to keep variety of foods hot and fresh until served. Unique features include:

- ALL drawers have an individual on/off switch and independent temperature control, and adjustable vents for humidity control providing superior quality control and versatility.
- Includes two full-size stainless steel 150mm food pans
- Supplied with 102mm legs, 1829mm cord and 10A plug. Castor option available.
- Easy to clean,

HDM-2

2-drawer model
 749W x 576D x 614Hmm (including legs)
 Supplied with cord and 10 amp plug.
 984watts / 2 Amp. Weight: 74Kg

LIST PRICE EA. \$5235



Black powdercoated exterior



HATCO PASTA COOKERS

BOIL, STEAM, WARM
 The multi-purpose HEAT-MAX well offers the flexibility of a food warmer, soup kettle, bain marie heater, steamer and pasta cooker all in one!
 With a range of temperature settings, HEAT-MAX can boil pasta and soup noodles, steam dim sum, keep food warm, hold soups, curry, gravies and toppings at safe serving temperatures.

RCTHW-1E
 Heat-Max Rectangular Single Heated Well to take 1/1 Gastronorm pan (not supplied).
 Touch panel for three temperature set points:
HOLD: 50-70°C SIMMER: 70-90°C BOIL: 90-100°C
 Energy saving Low Power mode
 Convenient Drain control
 Also available in Built-in Model with remote.
 Electrical: 3Kw, 12.5 amps.
 Supplied corded with 15amp plug.
LIST PRICE EA. \$1770



COUNTERTOP
RCTHW-6
 Heat-Max Pasta Cooker
Free Standing
 to take 1/1 Gastronorm pan (not supplied).
 Touch panel for three temperature set points:
HOLD: 50-70°C SIMMER: 70-90°C BOIL: 90-100°C
 Energy saving Low Power mode
 Convenient Drain control
 Insulated stainless steel design
 Electrical: 6Kw, 25 amps.
 No cord or plug supplied.
LIST PRICE EA. \$3025

BUILT-IN
RCTHW-6B
 Heat-Max Pasta Cooker
Built-In
 to take 1/1 Gastronorm pan (not supplied).
 Touch panel for three temperature set points:
HOLD: 50-70°C SIMMER: 70-90°C BOIL: 90-100°C
 Energy saving Low Power mode
 Convenient Drain control
 Insulated stainless steel design
 Electrical: 6Kw, 25 amps.
 No cord or plug supplied.
LIST PRICE EA. \$3175

SPECIFICATIONS

MODEL	OUTER DIMENSION MM	Kw	SHIP WEIGHT
RCTHW-1E	368W X 583L x 283H	3.0	9.6KG
RCTHW-6	368W X 610L x 282H	6.0	14KG
RCTHW-6B	390W X 610L x 298H	6.0	13KG



ACCESSORIES

RCTHW-BASKET

RCTHW Stainless Steel Noodle Basket
125mm diameter
(six required per unit)

LIST PRICE EA. \$85



RCTHW-PC

Pasta Cooker Tray

LIST PRICE EA. \$560



RCTHW-SP

Steamer Plate to accept bamboo
steamer baskets (not supplied).

LIST PRICE EA. \$320



RCTHW-1E shown left with optional RCTHW-SP Steam Adaptor Plate and above with optional Pasta Cooker Tray & Noodle Baskets

3CS-9B SANITISING SINK HEATER Balanced three phase

Maintaining a continuous supply of sanitising rinse water without taking up valuable space, the 3CS makes manual ware-washing faster and more convenient. Designed to fit under the sink, the 3CS is perfect for three or four compartment sinks, pot and pan sinks and bar sinks. Drain may be plumbed to open-sight waste drain.

3CS-9B SANITISING SINK HEATER

Weight: 15Kgs. Electrical: 9 Kw, 3 phase. Supplied uncorded and unplugged.

Dimensions: 203W x 435D x 321Hmm

LIST PRICE EA. \$5995



Pictured: 3CS-9 with optional temperature monitor



HATCO BUILT-IN HEATED WELLS

Hatco Built-In Heated Wells hold heated foods at safe serving temperatures. Compared to other models, these Hatco units offer larger drains with flat drain screens, more consistent holding temperatures through superior element design, heavier stainless steel construction, easier-to-service design for quick-change of components, and a remote thermostat with separate power switch. Suitable for wet or dry operation.

All units are supplied with a control panel and connected with a 918mm flexible conduit for remote mounting and include a 3/4" NPT drain fitting.

BUILT-IN RECTANGULAR HEATED WELL - FULL SIZE

HWB-FULD

Heated Well with drain - 1/1 Gastronorm.

Dimensions: 348W x 553D x 218Hmm

Controller dimensions: 161W x 92D x 196Hmm

Electrical: 1.2kw, 5 amp

Weight: 10Kg

Drain: 3/4" NPT fitting

LIST PRICE EA. **\$1675**



Remote control with 918mm conduit for convenient fitting



(Pictured with accessory food pan).

BUILT-IN ROUND HEATED WELLS with drain fitting

CODE	DESCRIPTION	KW	AMP	WT	\$
HWB-4QTD	3.8Litre (4 Quart) Heated Well with drain.	0.6kw	2.5A	5Kg	1565
HWB-7QTD	6.6Litre (7 Quart) Heated Well with drain.	0.6kw	2.5A	5Kg	1600
HWB-11QTD	10.1Litre (11 Quart) Heated Well with drain.	0.6kw	2.5A	5Kg	1610

All wells come with 3/4" NPT drain fitting.



(Pictured with accessory pans see below).

OPTIONAL PAN INSERTS & LIDS (not supplied with wells above)

CODE	DESCRIPTION	\$
4QT-PAN&LID	4 Quart (3.8L) Round Well and Notched Lid.	320
7QT-PAN&LID	7 Quart (6.65L) Round Well and Notched Lid.	360
11QT-PAN&LID	11 Quart (10.41L) Round Well and Notched Lid.	395





HATCO SALAMANDERS

Hatco's Salamander range is specially designed for versatility in the kitchen with the capabilities to cook, grill, and reheat food. With the patented movable heat unit housing, maximum thermal transfer is achieved and maximum power is only consumed whilst actually in cook mode. The unparalleled start-up speed is a result of Hatco's "INSTANT ON" heating elements located in the upper housing. Hatco® Salamanders offer unrivalled energy efficiency and easy operation to suit the most demanding requirements - of fine dining restaurants to fast food outlets.

TMS-1H THERMAX SALAMANDER

Movable upper housing to reduce the heat loss to food areas.

- The high powered heating elements are ready for use within 10 seconds.
- Two sets of independently controlled heating element sections give the benefits of flexibility and energy conservation.
- Cook mode selection switch controls left, right or both locations.
- Includes a hold mode switch that reduces power to 25% and keeps food at proper serving temperatures.
- Unit can be placed on a counter-top or mounted to any non-combustible wall with appropriate rigidity.
- Unit comes standard with grill, drip pan and wall mounting bracket.

Weight: 70Kgs. Dimensions: 600W x 503D x 515Hmm.

Electrical: 4Kw 17.4 amp. Supplied with cord but no plug.

LIST PRICE EA. \$6050



TMS2-1H SALAMANDER - DIGITAL CONTROL

Optimum temperature is reached instantly and efficiently when food products are placed on the grill plate.

- Instant-On heating elements located in the upper housing
- Plate detection feature activates the Instant-On heating elements when a food plates is placed on the grill plate, and deactivates when removed
- Heating elements are only on when in use, eliminating residual heat in the kitchen
- Made of stainless steel for easy cleaning and durability
- Can be placed on a countertop or wall-mounted
- Hold mode could be adjusted to save 25-50% power
- Adjustable upper housing giving 170mm of vertical movement
- Flat, tactile control panel

Ship Weight: 80Kgs Overall Dimensions: 630W x 505D x 568Hmm.

Electrical: 4.1kw 17.2 amp. Supplied with cord but no plug.

LIST PRICE EA. \$7000



Tight for space and storage of meals for peak periods?

JACKSTACK offers so many advantages in storage, preparation and serving, you'll wonder how you did without it.

JACKSTACK is the world leader in the efficient storage and transport of up to 104 plates in minimum time from kitchen to storage or banquet areas.

Generous 150mm diameter wheels allow for easy maneuverability of the Jackstack anywhere, and the plate racks are easily adjustable to suit all applications - even mixing plate sizes.

Models provide 50mm spacing between plate supports and they can be loaded and unloaded from four sides, and carry up to 400 empty plates to the dishwasher.



Designed by Chefs, for chefs

JACKSTACK Model JS104

Makes it possible to stack between 12 to 104 plates of any size. Different size plates can be accommodated by adjusting the racks to suit. (For pizza applications, a special 'P' model longer arm unit is available at extra cost).

The unit comes with four castors (two with brakes), and easy to follow assembly instructions.

Assembled Dimensions: 600W x 600D x 1790Hmm

Shipping Dimensions: 800W x 620D x 300Hmm

Weight: 28Kg

CODE	CAPACITY	SPACING	DIMENSION	\$
JS104	104 plates	50mm	600x600x1790mmH	2990

JACKSTACK OPTIONS

Thermocover for JS104

Preserves 72-104 plates in transit with warm or cold food.

Made of industrial High Tenacity PES fabric, with polyester fibre centre layer.

Includes special arm extensions.

Complete with 4 horizontal and 4 vertical zippers.

Washable - hygienic in use.

Dimensions: 720 x 720 x 1590Hmm.

Shipping Dimensions: 430 x 310 x 260Hmm

Weight: 6Kg

MODEL	DESCRIPTION	\$
JS104TC	Thermal covers available on request (pictured)	1980
JS901PC	Non thermal covers for 104 plate unit	390



MODEL JS104TC Thermal Cover



Yellow Brand Induction Units, one of the leaders in induction technology to the Australian market, now established and recognised as a highly efficient and safe cooking technology. Yellow Induction units are made to last and offer superior performance and quality compared to lesser units. And each Yellow Induction model comes with our exclusive 13 month warranty for absolute peace of mind when you next specify for that important project.

YELLOW INDUCTION HOBS

SINGLE PORTABLE COUNTER-TOP HOBS

Y2500TT Counter Top Unit

Powerful 2500W portable table top unit plug-in self contained for use in kitchen / buffets.

Dimensions: 328 x 422 x 100mm

Ceramic glass dimension: 273 x 273 x 4mm (thick).

2500 watts. 15 amp plug.

LIST PRICE EA. \$1990



Y3500TT Counter Top Unit

High Power 3500W portable table top unit plug-in self contained for use in kitchen / buffets.

Dimensions: 385 x 520 x 177mm

Ceramic glass dimension: 300 x 300 x 6mm (thick).

3500 watts. 15 amp plug.

LIST PRICE EA. \$3780



Y1000WCS

Free Standing Unit mounted in attractive chrome stand with on-board controls and rear chafer support.

Dimensions: 385 x 385 x 100mm

Ceramic glass dimension: 360 x 380 x 4mm (thick).

1000 watts. 10 amp plug.

LIST PRICE EA. \$2170



Y300 Fanless Induction Warmer

300 watt drop-in buffet/warmer. Can daisy chain up to 4 units. No ventilation under required

Dimensions: 380 x 360 x 91.2mm

300 watts. 10 amp plug.

LIST PRICE EA. \$1420

Y300R Remote Controller

LIST PRICE EA. \$85





All Yellow Induction units offer Automatic Safety Shut-Off, Material Compatibility and small object Detector, Overheating Protection Device and Automatic Resetting. All these In-built/drop-in induction units have the same cut-out and require ventilation for optimum performance. Consult your FSM representative for more information.

SINGLE DROP-IN HOB UNITS

Y1000NT Drop In Unit

Perfect drop-in unit for buffet warming.
 Dimensions: 360 x 380 x 100mm
 Ceramic glass dimension: 360 x 380 x 4mm (thick).
 Remote controller supplied with flex cord.
 1000 watts. 10 amp plug.

LIST PRICE EA. \$1680



Y2000D Drop In Unit

Powerful 2000 Watts of power in a drop-in unit, ideal for buffet/kitchen/holding with remote control.
 Dimensions: 360 x 380 x 100mm
 Ceramic glass dimension: 360 x 380 x 4mm (thick).
 Remote controller supplied with flex cord.
 2000 watts. 10 amp plug.

LIST PRICE EA. \$1920



Y2500AD Drop In Unit

High output 2500W drop-in unit for kitchen or buffet use.
 Dimensions: 360 x 380 x 100mm
 Ceramic glass dimension: 360 x 380 x 4mm (thick).
 Remote controller supplied with flex cord.
 2500 watts. 15 amp plug.

LIST PRICE EA. \$2250



Note: all these drop-in units have the same cutout dimensions



Yellow Induction built-in cooktops offer the rugged performance demanded of every commercial kitchen. Framed with stainless steel, these Dual Hob models have the capacity and versatility in one unit.

BUILT-IN COOKTOPS

Y3500DDSS

Built in Dual Hob Unit with remote controller for maximum performance and power, this dual unit offers versatility in a compact built-in unit.

Dimensions: 450 x 700 x 208mm

Comprises two 2 X 3500 watt cooking/warming surfaces.

Electrical: 7.2kw, 30 amp, Single phase. Unit supplied unplugged.

LIST PRICE EA. \$8800



**2 x
3500
WATTS
POWER**

MULTIZONE INDUCTION WARMER

YMC-2-1700

Versatile Multi Zone unit with 1700W for warming/holding flexibility. Glass touch control panel and 10 hour timer.

Dimension: 806W x 386D x 111mmH

Vitro-Ceramic Plate Dimension:
800W x 380D x 4mm (thick).

LIST PRICE EA. \$5690





The new era of warming, **MULTI-ZONE Induction technology** that heats all points on the ceramic glass top. Newly developed technology can suit any shape and size of induction compatible display chafer, saucer, small utensils, pots and pans. Unlike normal Induction Units, these Yellow Multi-Zone units allow almost unlimited flexibility in pan size and placement and look fabulous in any setting.

MULTI-ZONE BUFFET INDUCTION

YMC-2-2500

Versatile Multi Zone unit with two x 2500W units for warming/holding flexibility. Complete with remote generator rack and two (2) remote controller panels (as below).
Dimension: 800W x 380D x 66mmH
Ceramic Glass Dimension: 800W x 380D x 6mm (thick).

LIST PRICE EA. \$10500



Two Remote controller panels supplied

**5000
WATTS
POWER**



YMC-3-2500

Versatile Multi Zone unit with three x 2500W units for warming/holding flexibility. Complete with remote generator rack and three (3) remote controller panels (as below).
Dimension: 1180W x 380D x 66mmH
Ceramic Glass Dimension: 1180W x 380D x 6mm (thick).

LIST PRICE EA. \$14900



Three Remote controller panels supplied

**7500
WATTS
POWER**



REMOTE GENERATOR CONTROL & RACK (included with above)

Compact and remote type generator with easy access for maintenance and less interruption to daily operation. These units are supplied with the cooktops above and can be located within 3m of the cooking surface.

MODEL	DIMENSIONS	CABLE LENGTH	TOTAL POWER
YMC-2-2500	385W x 450D x 275mmH	3m*	5kw, 30 amp.
YMC-3-2500	385W x 450D x 387.5mmH	3m*	7.5kw, 45 amp.

*Max 3m remote cable between hob and generator.
Each Generator is supplied with its own 15A plug.
YMC-2-2500 = 2 power cords and 15A plugs.
YMC-3-2500 = 3 power cords and 15A plugs.

All Multi-zone Induction generator units require adequate ventilation for maximum performance.

YMC-2-2500
GENERATOR RACK
SHOWN
MOUNTED REMOTELY



FOODSERVICE PRODUCTS						
Catalogue page no.	Image	Item number	Description	List Price EA	Pack size	Pack Price
49		554007	Versapour™ Polycarbonate Pitcher 1.77L Lip design allows easy pour of ice from front or either side; Sure Grip handle; Break resistant polycarbonate; 210Hmm	\$21.25	6	\$127.40
49		553807	Polycarbonate Clear Pitcher 1.5L Ice trap retains ice or beer foam. 195Hmm x base dia 85mm	\$20.40	6	\$122.50
41		580807	Louis™ SAN Tumbler 240mL Stackable design 86Hmm x top dia 76mm	\$8.70	24	\$208.80
41		581007	Louis™ SAN Tumbler 300mL Stackable design 116Hmm x top dia 73mm	\$6.05	24	\$144.80
42		400807	Crystalon® Stack-All® SAN Tumbler 250mL 102Hmm x top dia 71mm	\$3.30	48	\$158.70
32		190007	Clear Polycarbonate Plate Cover 238mmDia x 65Hmm	\$15.80	12	\$189.30
32		198907	Clear Polycarbonate Plate Cover 260mmDia x 76Hmm	\$19.15	12	\$229.70
144		OP30500	Pour Free Economical Free Flow Pourer – Red; BPA free; 25.4L x 25.4W x 76Hmm	\$1.05	12	\$12.60
145		WPM8538	Tapered Metal Pourers; Medium flow; Sturdy metal construction; Choice of three flow rates; Chrome plated; 25.4L x 25.4W x 76Hmm	\$8.30	12	\$99.60
204		4314107	Clear Polycarbonate Measuring Cup - 250ml; NSF approved and dish washer safe. 102L x 111W x 84Hmm	\$13.35	12	\$160.10

FOODSERVICE PRODUCTS

Catalogue page no.	Image	Item number	Description	List Price EA	Pack size	Pack Price
204		4314207	Clear Polycarbonate Measuring Cup - 500mL; NSF approved and dish washer safe.130L x 121W x 107Hmm	\$23.20	6	\$139.20
204		4314307	Clear Polycarbonate Measuring Cup 1000mL; NSF approved and dishwasher safe 146L x 160W x 135Hmm	\$27.10	6	\$162.20
163		1400GL004	GripLite® Round Polypropylene Tray 370mm – Black; Moulded in rubber liner to prevent slipping and sliding	\$21.35	12	\$256.15
163		1600GL004	GripLite® Round Polypropylene Tray 410mm – Black; Moulded in rubber liner to prevent slipping and sliding	\$36.20	12	\$434.30
162		1400GR2004	Griptite™ 2- Round Non-Skid Tray 350mm – Black; specially designed stain & odour resistant non-skid surface that is more durable and better looking	\$48.70	12	\$584.65
162		1600GR2004	Griptite™ 2- Round Non-Skid Tray 400mm – Black; specially designed stain & odour resistant non-skid surface that is more durable and better looking	\$66.50	12	\$787.60
-		DXSMC1520NSQ44	Non skid tray 381 x 508mm Stain, scratch and odour resistant; Sturdy fiberglass construction with reinforced edges; Quarry print design; Dishwasher safe	\$86.85	12	\$1041.70
-		DX1089M23	Glasteel™ flat tray 381 x 508mm – Grey Strong top-of-the-line Glasteel construction; Dishwasher safe	\$53.20	12	\$638.00
150		2015FG017	Glasteel™ flat tray 381 x 514mm – Red Strong top-of-the-line Glasteel construction; Dishwasher safe	\$48.15	12	\$577.70

FOODSERVICE PRODUCTS						
Catalogue page no.	Image	Item number	Description	List Price EA	Pack size	Pack Price
145		430607	Polycarbonate Scoop - 180mL - Clear Total length 276mm	\$9.20	12	\$110.00
139		PS601N00	Store 'N Pour Bar Service Kit – 950mL Dishwasher safe; Colour co-ordinated spouts and caps for easy product identification; 334Hmm x 89mm dia	\$19.70	12	\$236.65
139		PS701B00	Store 'N Pour Bar Service Kit – 1900mL Dishwasher safe; Colour co-ordinated spouts and caps for easy product identification; 353Hmm x 124mm dia	\$21.95	6	\$131.55
-		DXSB607	SAN Clear Square bowl - 175ml capacity Look and feel of glass with the durability of plastic; Break resistant; Dishwasher safe; 102L x 102W x 32Hmm	\$3.95	96	\$375.85
-		DXSQD1007	SAN Clear Square bowl - 290ml capacity Look and feel of glass with the durability of plastic; Break resistant; Dishwasher safe; 100L x 100W x 45Hmm	\$5.50	48	\$262.20
-		DXSB1203	SAN Black Square bowl - 350ml Capacity Look and feel of china with the durability of plastic; Break resistant; Dishwasher safe; 102L x 102W x 64Hmm	\$8.40	48	\$402.50
-		DXSWC507	SAN Clear Tulip bowl - 150ml capacity Look and feel of glass with the durability of plastic; Break resistant; Dishwasher safe; Diameter: 95mm; Height: 45Hmm	\$3.75	96	\$359.60
-		DX11820174	Disposable clear dome lid to fit tulip cup DXSWC507	\$0.35	1000	\$319.00
111		CM1100C1402	Coldmaster® CoolCheck Food Pan 1/1 Size; Once charged overnight, keeps food cold for up to 8 hours; Dimensions: 323W x 525L x 163Hmm	\$307.40	1	\$307.40
111		CM1101C1402	Coldmaster® CoolCheck Food Pan 1/2 Size; Once charged overnight, keeps food cold for up to 8 hours; Dimensions: 263W x 323L x 153Hmm	\$242.45	1	\$242.45

FOODSERVICE PRODUCTS

Catalogue page no.	Image	Item number	Description	List Price EA	Pack size	Pack Price
111		CM1102C1402	Coldmaster® CoolCheck Food Pan 1/3 Size; Once charged overnight, keeps food cold for up to 8 hours; Dimensions: 175W x 323L x 153Hmm	\$136.90	1	\$136.90
111		CM1103C1402	Coldmaster® CoolCheck® Divided Food Pan; 1/3 Size; Once charged overnight, keeps food cold for up to 8 hours; Dimensions: 175W x 323L x 153Hmm	\$136.90	1	\$136.90
111		CM1104C1402	Coldmaster® CoolCheck Food Pan 1/6 Size; Once charged overnight, keeps food cold for up to 8 hours; Dimensions: 159W x 174L x 150Hmm	\$118.35	1	\$118.35
113		CM104902	Coldmaster® Full-size Coldpan with Organizer Holds 9 ninth-size food pans (pans not included); Capacity (total): 23L; Colour: White; Dimensions (outside): 407W x 611L x 190Hmm	\$742.40	1	\$742.40
223		30860HH13	StorPlus™ High Heat Food Pan Double handle; 1/3 Size; 65mm deep; Colour: Amber; 176W x 325Lmm; Handle length 95mm;	\$78.90	6	\$473.30
223		30860H13	StorPlus™ High Heat Food Pan Single handle; 1/3 Size; 65mm deep; Colour: Amber; 176W x 325Lmm; Handle length 95mm;	\$78.90	6	\$473.30
220		10200B07	StorPlus™ Full Size Clear Polycarbonate Food Pan Capacity: 6.6L 324W x 527Lmm; 65 mm deep	\$25.75	6	\$154.55
220		10201B07	StorPlus™ Full Size Clear Polycarbonate Food Pan Capacity: 13.3L 324W x 527Lmm; 100 mm deep	\$33.00	6	\$198.05
220		10202B07	StorPlus™ Full Size Clear Polycarbonate Food Pan Capacity: 24.1L 324W x 527Lmm; 150 mm deep	\$44.10	6	\$264.50

FOODSERVICE PRODUCTS						
Catalogue page no.	Image	Item number	Description	List Price EA	Pack size	Pack Price
220		10220B07	StorPlus™ Half Size Clear Polycarbonate Food Pan Capacity: 3.12L 324W x 264Lmm; 65 mm deep	\$14.50	6	\$87.00
220		10221B07	StorPlus™ Half Size Clear Polycarbonate Food Pan Capacity: 5.7L 324W x 264Lmm; 100 mm deep	\$17.40	6	\$104.40
220		10222B07	StorPlus™ Half Size Clear Polycarbonate Food Pan Capacity: 8L 324W x 264Lmm; 150 mm deep	\$22.05	6	\$132.25
221		3066007	StorPlus™ 1/3 Size Clear Polycarbonate Food Pan Capacity: 2.6L 324W x 175Lmm; 65 mm deep	\$10.45	6	\$62.65
221		3066107	StorPlus™ 1/3 Size Clear Polycarbonate Food Pan Capacity: 3.6L 324W x 175Lmm; 100 mm deep	\$13.95	6	\$83.50
221		3066207	StorPlus™ 1/3 Size Clear Polycarbonate Food Pan Capacity: 5.3L 324W x 175Lmm; 150 mm deep	\$16.85	6	\$100.95
221		3068007	StorPlus™ 1/4 Size Clear Polycarbonate Food Pan Capacity: 1.8L 162W x 264Lmm; 65 mm deep	\$10.45	6	\$62.65
221		3068107	StorPlus™ 1/4 Size Clear Polycarbonate Food Pan Capacity: 2.7L 162W x 264Lmm; 100 mm deep	\$12.20	6	\$73.10
221		3068207	StorPlus™ 1/4 Size Clear Polycarbonate Food Pan Capacity: 4.3L 162W x 264Lmm; 150 mm deep	\$14.40	6	\$86.65
221		3068307	StorPlus™ 1/6 Size Clear Polycarbonate Food Pan Capacity: 0.95L 137W x 151Lmm; 65 mm deep	\$7.55	6	\$45.25

FOODSERVICE PRODUCTS						
Catalogue page no.	Image	Item number	Description	List Price EA	Pack size	Pack Price
221		3068407	StorPlus™ 1/6 Size Clear Polycarbonate Food Pan Capacity: 1.9L 137W x 151Lmm; 100 mm deep	\$8.60	6	\$51.50
221		3068607	StorPlus™ 1/9 Size Clear Polycarbonate Food Pan Capacity: 0.68L 108W x 175Lmm; 65 mm deep	\$7.80	6	\$46.65
221		3068807	StorPlus™ Clear Food Pan 1/9 Size; Ideal for use in chilled/frozen storage; 108W x 176Lmm, 150mm Deep.	\$11.05	6	\$66.15
220		10200B03	StorPlus™ Full Size Black Polycarbonate Food Pan Capacity: 6.62L 324W x 527Lmm; 65 mm deep	\$24.95	6	\$149.65
220		10201B03	StorPlus™ Full Size Black Polycarbonate Food Pan Capacity: 13.25L 324W x 527Lmm; 100 mm deep	\$31.35	6	\$187.90
220		10202B03	StorPlus™ Full Size Black Polycarbonate Food Pan Capacity: 24.1L 324W x 527Lmm; 150 mm deep	\$42.90	6	\$257.50
220		10220B03	StorPlus™ Half Size Black Polycarbonate Food Pan Capacity: 3.12L 324W x 264Lmm; 65 mm deep	\$13.90	6	\$83.50
220		10221B03	StorPlus™ Half Size Black Polycarbonate Food Pan Capacity: 5.7L 324W x 264Lmm; 100 mm deep	\$17.40	6	\$104.40
220		10222B03	StorPlus™ Half Size Black Polycarbonate Food Pan Capacity: 8L 324W x 264Lmm; 150 mm deep	\$22.05	6	\$132.25
221		3066003	StorPlus™ 1/3 Size Black Polycarbonate Food Pan Capacity: 2.6L 324W x 175Lmm; 65 mm deep	\$10.45	6	\$62.65





FOODSERVICE PRODUCTS						
Catalogue page no.	Image	Item number	Description	List Price EA	Pack size	Pack Price
221		3066103	StorPlus™ 1/3 Size Black Polycarbonate Food Pan Capacity: 3.6L 324W x 175Lmm; 100 mm deep	\$13.95	6	\$76.35
221		3066203	StorPlus™ 1/3 Size Black Polycarbonate Food Pan Capacity: 5.3L 324W x 175Lmm; 150 mm deep	\$16.25	6	\$97.45
221		3068003	StorPlus™ 1/4 Size Black Polycarbonate Food Pan Capacity: 1.8L 162W x 264Lmm; 65 mm deep	\$10.45	6	\$62.65
221		3068103	StorPlus™ 1/4 Size Black Polycarbonate Food Pan Capacity: 2.7L 162W x 264Lmm; 100 mm deep	\$12.20	6	\$73.10
221		3068203	StorPlus™ 1/4 Size Black Polycarbonate Food Pan Capacity: 4.3L 162W x 264Lmm; 150 mm deep	\$13.95	6	\$83.55
221		3068303	StorPlus™ 1/6 Size Black Polycarbonate Food Pan Capacity: 0.95L 137W x 151Lmm; 65 mm deep	\$7.55	6	\$45.25
221		3068403	StorPlus™ 1/6 Size Black Polycarbonate Food Pan Capacity: 1.9L 137W x 151Lmm; 100 mm deep	\$8.60	6	\$47.10
221		3068503	StorPlus™ 1/6 Size Black Polycarbonate Food Pan Capacity: 2.4L 137W x 151Lmm; 150 mm deep	\$11.60	6	\$69.60
221		3068603	StorPlus™ 1/9 Size Black Polycarbonate Food Pan Capacity: 0.68L 108W x 175Lmm; 65 mm deep	\$7.80	6	\$46.65
221		3068703	StorPlus™ 1/9 Size Black Polycarbonate Food Pan Capacity: 1.1L 108W x 175Lmm; 100 mm deep	\$9.30	6	\$56.70

FOODSERVICE PRODUCTS						
Catalogue page no.	Image	Item number	Description	List Price EA	Pack size	Pack Price
220		1021507	StorPlus™ 1/1 Size Clear Polycarbonate Drain Shelf 251W x 451L x 15Hmm	\$18.00	6	\$107.90
220		1023507	StorPlus™ 1/2 Size Clear Polycarbonate Drain Shelf 194W x 254L x 15Hmm	\$8.35	6	\$50.15
221		3067007	StorPlus™ 1/3 Size Clear Polycarbonate Drain Shelf 121W x 264L x 15Hmm	\$7.80	6	\$46.65
221		3069507	StorPlus™ 1/4 Size Clear Polycarbonate Drain Shelf 107W x 206L x 14Hmm	\$6.65	6	\$39.70
221		3068907	StorPlus™ 1/6 Size Clear Polycarbonate Drain Shelf 108W x 121L x 13Hmm	\$3.05	6	\$18.10
221		1033507	StorPlus™ 1/9 Size Clear Polycarbonate Drain Shelf 61W x 127L x 16Hmm	\$2.35	6	\$13.95
220		10210U07	StorPlus™ 1/1 Size Clear Polycarbonate Handled Lid, Unnotched 327W x 527L x 22Hmm	\$20.90	6	\$125.30
220		10230U07	StorPlus™ 1/2 Size Clear Polycarbonate Handled Lid, Unnotched 264W x 324L x 22Hmm	\$11.05	6	\$66.15
221		10279Z07	StorPlus™ EZ Access 1/3 Size Clear Polycarbonate Hinged Lid with Handle, Single Notched 178W x 324L x 28Hmm	\$19.75	6	\$118.35
221		10319Z07	StorPlus™ EZ Access 1/6 Size Clear Polycarbonate Hinged Lid with Handle, Single Notched 160W x 175L x 28Hmm	\$11.05	6	\$66.15

FOODSERVICE PRODUCTS

Catalogue page no.	Image	Item number	Description	List Price EA	Pack size	Pack Price
221		10339Z07	StorPlus™ EZ Access 1/9 Size Clear Polycarbonate Hinged Lid with Handle, Single Notched 110W x 175L x 28Hmm	\$11.60	6	\$69.60
202		4039302	Galaxy™ Flat Pastry Brush – white; 100mm wide; Nylon bristles with high fluid retaining capacity	\$34.80	12	\$417.60
202		4039002	Galaxy™ Flat Pastry Brush – white; 38mm wide; Nylon bristles with high fluid retaining capacity	\$21.50	12	\$257.55
56		S31202	Heavyweight Melamine Oval Ramekin; Colour – white; 90mL Capacity; Dimensions: 67W x 87L x 67Hmm	\$4.90	48	\$233.90
58		085242	Melamine Smooth Round Ramekin; Colour – “Bone”; 60mL Capacity; Dimensions: 67mmDia x 32Hmm	\$4.10	72	\$292.35
265		4053200	Universal Onion Cutter Cleaning Brush; Bristle length – 108mm; Superior, high grade stiff nylon bristle, long enough to reach crevices; All parts FDA compliant.	\$16.85	8	\$134.60
200		4037400	Sparta® Flat Boar Bristle Basting Brush; 50mm wide; Double-boiled, bleached, and sterilized premium Boar bristles; withstand temperatures up to 180°C	\$24.95	12	\$299.20
201		4037800	Sparta® Meteor® Boar Bristle Basting Brush; 50mm wide; Moulded plastic handle with projecting hook to allow brush to rest on container rim	\$25.55	12	\$306.25
269		4071100	Sparta® Grill Polishing Pads; Apply with cooking oil to protect the grill cure and remove excess cooked-on foods; 102W x 127Lmm; 64mm thickness	\$23.20	6	\$139.20
269		4067100	Sparta® Scratch Brush and Scraper; Carbon Steel Bristles; Bristle length 32mm; Brush size 140mm; Total length 291mm	\$18.00	12	\$215.80

FOODSERVICE PRODUCTS

Catalogue page no.	Image	Item number	Description	List Price EA	Pack size	Pack Price
269		4071000	Sparta® Grill Brick; Apply with oil to protect the grill, cure and remove excess cooked on foods. Dimensions: 203L x 102W x 89Hmm	\$8.85	12	\$105.80
268		4029300	Pizza Oven Brush with Scraper; Crimped Brass wire bristles and a full length Aluminum Scraper; 89mm wide; Bristle length 32mm	\$58.00	12	\$696.00
264		4546300	Sparta® Utility Scrub Brush; Stiff Palmyra bristles for woks and electric griddles; and high heat cleaning. Head: 216Lx102Wmm; Bristle length 42mm	\$10.70	12	\$128.10
268		4029000	Sparta® Broiler Master; Stainless steel wire bristles and scrapers; Excellent for removing heavy carbon deposits, rust and burned on food build up. One side of the brush has semi stiff and the other with coarse bristles; Head 216W x 127H x 775Lmm; Bristle length 25mm	\$91.65	6	\$549.85
253		107123	Save-All™ Stackable Silverware Tray Colour: Grey 292W x 540L x 95Hmm	\$30.20	6	\$180.95

KITCHEN ACCESSORIES

Catalogue page no.	Image	Item number	Description	List Price EA	Pack size	Pack Price
207		492104	Measure Miser® measuring spoon; Solid spoon; Short Handle; Colour: Yellow; Capacity: 30mL	\$10.45	12	\$125.30
207		492304	Measure Miser® measuring spoon; Perforated spoon; Short Handle; Colour: Yellow; Capacity: 30mL	\$10.45	12	\$125.30
207		492201	Measure Miser® measuring spoon; Solid spoon; Short Handle; Colour: Brown; Capacity: 45mL	\$12.80	12	\$153.15
207		496101	Measure Miser® measuring spoon; Perforated spoon; Short Handle; Colour: Brown; Capacity: 45mL	\$12.80	12	\$153.15
207		492405	Measure Miser® measuring spoon; Solid spoon; Short Handle; Colour: Red; Capacity: 60mL	\$15.10	12	\$181.00
207		496205	Measure Miser® measuring spoon; Perforated spoon; Short Handle; Colour: Red; Capacity: 60mL	\$15.10	12	\$181.00
207		492602	Measure Miser® measuring spoon; Solid spoon; Short Handle; Colour: White; Capacity: 90mL	\$16.10	12	\$192.10
207		492702	Measure Miser® measuring spoon; Perforated spoon; Short Handle; Colour: White; Capacity: 90mL	\$16.10	12	\$192.10
207		492808	Measure Miser® measuring spoon; Solid spoon; Short Handle; Colour: Forest Green; Capacity: 120mL	\$16.85	12	\$201.85
207		492908	Measure Miser® measuring spoon; Perforated spoon; Short Handle; Colour: Forest Green; Capacity: 120mL	\$16.85	12	\$201.85



KITCHEN ACCESSORIES

Catalogue page no.	Image	Item number	Description	List Price EA	Pack size	Pack Price
207		493306	Measure Miser® measuring spoon; Solid spoon; Short Handle; Colour: Beige; Capacity: 150mL	\$17.65	12	\$211.60
207		496606	Measure Miser® measuring spoon; Perforated spoon; Short Handle; Colour: Beige; Capacity: 150mL	\$17.65	12	\$211.60
207		493114	Measure Miser® measuring spoon; Solid spoon; Short Handle; Colour: Blue; Capacity: 240mL	\$21.50	12	\$257.55
207		496814	Measure Miser® measuring spoon; Perforated spoon; Short Handle; Colour: Blue; Capacity: 240mL	\$21.50	12	\$257.55
207		395604	Measure Miser® measuring spoon; Solid spoon; Long Handle; Colour: Yellow; Capacity: 30mL	\$10.70	12	\$128.10
207		395704	Measure Miser® measuring spoon; Perforated spoon; Long Handle; Colour: Yellow; Capacity: 30mL	\$10.70	12	\$128.10
207		396005	Measure Miser® measuring spoon; Solid spoon; Long Handle; Colour: Red; Capacity: 60mL	\$15.35	12	\$183.75
207		396105	Measure Miser® measuring spoon; Perforated spoon; Long Handle; Colour: Red; Capacity: 60mL	\$15.35	12	\$183.75
207		397002	Measure Miser® measuring spoon; Solid spoon; Long Handle; Colour: White; Capacity: 90mL	\$16.10	12	\$192.10
207		397102	Measure Miser® measuring spoon; Perforated spoon; Long Handle; Colour: White; Capacity: 90mL	\$16.10	12	\$192.10









KITCHEN ACCESSORIES

Catalogue page no.	Image	Item number	Description	List Price EA	Pack size	Pack Price
207		398008	Measure Miser® measuring spoon; Solid spoon; Long Handle; Colour: Forest Green; Capacity: 120mL	\$16.85	12	\$201.85
207		398108	Measure Miser® measuring spoon; Perforated spoon; Long Handle; Colour: Forest Green; Capacity: 120mL	\$16.85	12	\$201.85
207		399003	Measure Miser® measuring spoon; Solid spoon; Long Handle; Colour: Black; Capacity: 180mL	\$19.15	12	\$229.70
207		399103	Measure Miser® measuring spoon; Perforated spoon; Long Handle; Colour: Black; Capacity: 180mL	\$19.15	12	\$229.70
207		399214	Measure Miser® measuring spoon; Solid spoon; Long Handle; Colour: Blue; Capacity: 240mL	\$21.50	12	\$257.55
207		399314	Measure Miser® measuring spoon; Perforated spoon; Long Handle; Colour: Blue; Capacity: 240mL	\$21.50	12	\$257.55

FOOD STORAGE SOLUTIONS

Catalogue page no.	Image	Item number	Description	List Price EA	Pack size	Pack Price
228		10720AF07	StorPlus™ Clear Polycarbonate Square Food Storage Container; Capacity 2L; Writing Surface to record date; Handles with drain holes; 181L x 181W x 97Hmm	\$15.10	6	\$90.50
228		1072107	StorPlus™ Clear Polycarbonate Square Food Storage Container; Capacity 4L; Writing Surface to record date; Handles with drain holes; 181L x 181W x 185Hmm	\$23.20	6	\$139.20
228		1072207	StorPlus™ Clear Polycarbonate Square Food Storage Container; Capacity 6L; Writing Surface to record date; Handles with drain holes; 222L x 222W x 186Hmm	\$29.00	6	\$175.00
228		1072307	StorPlus™ Clear Polycarbonate Square Food Storage Container; Capacity 8L; Writing Surface to record date; Handles with drain holes; 222L x 222W x 229Hmm	\$34.25	6	\$205.35
228		1072407	StorPlus™ Clear Polycarbonate Square Food Storage Container; Capacity 12L; Writing Surface to record date; Handles with drain holes; 282L x 282W x 209Hmm	\$46.40	6	\$278.40
228		1072507	StorPlus™ Clear Polycarbonate Square Food Storage Container; Capacity 18L; Writing Surface to record date; Handles with drain holes; 282L x 282W x 320Hmm	\$68.45	6	\$410.65
228		1072607	StorPlus™ Clear Polycarbonate Square Food Storage Container; Capacity 22L; Writing Surface to record date; Handles with drain holes; 282L x 282W x 399Hmm	\$85.85	6	\$515.05
228		1074008	StorPlus™ Square Container Lid; To Suit StorPlus™ Polycarbonate Square Food Storage Containers of capacity 2L, 4L; 186W x 186L x 16Hmm	\$6.30	6	\$37.60
228		1074105	StorPlus™ Square Container Lid; To Suit StorPlus™ Polycarbonate Square Food Storage Containers of capacity 6L, 8L; 229W x 229L x 16Hmm	\$7.55	6	\$45.25
228		1074260	StorPlus™ Square Container Lid; To Suit StorPlus™ Polycarbonate Square Food Storage Containers of capacity 12L, 18L, 22L; 289L x 289W x 16Hmm	\$11.05	6	\$66.15

FOOD STORAGE SOLUTIONS						
Catalogue page no.	Image	Item number	Description	List Price EA	Pack size	Pack Price
233		BIN2702	Ingredient Bin; Capacity 102 Litre; Colour White; Heavy duty non-marking castors. Lids slide for easy opening; 724L x 322W x 708Hmm	\$696.00	1	\$696.00
233		BIN3602	Ingredient Bin; Capacity 136 Litre; Colour White; Heavy duty non-marking castors. Lids slide for easy opening; 750 L x 390 W x 718Hmm	\$754.00	1	\$754.00
324		34102002	Bronco™ White Round Bin; Capacity 75L; Heavy duty construction with double reinforced stress ribs; NSF2 approved for food storage; Bottom dia 413mm x 585Hmm; Top dia 508mm; Top dia with handles 585mm	\$67.30	6	\$403.70
324		34102102	Bronco™ Round Waste Bin Lid to Suit 75 Litre Bronco™ Round Waste Bin; Colour White; Dimensions: 508mm dia x 32Hmm	\$19.15	6	\$114.85
325		3691103	Bronco™ Round Waste Container Dolly; Suits Bronco™ Round Waste Bins; Simple twist-to-lock feature attaches dolly to container; Five 76mm castors; 454mm dia x 127Hmm	\$133.40	2	\$266.80
252		N4401103	Comfort Curve™ Tote Box Colour: Black; BPA Free & NSF approved; 546W x 394L x 178Hmm	\$42.80	12	\$513.65
252		N4401102	Comfort Curve™ Tote Box Colour: White; BPA Free & NSF approved; 546W x 394L x 178Hmm	\$42.80	12	\$513.65
226		1062007	StorPlus™ Clear Polycarbonate Food Box Capacity: 19L; 457W x 660L x 89Hmm	\$60.90	6	\$365.40
226		1061007	StorPlus™ Clear Polycarbonate Food Box Capacity: 7L; 304W x 457L x 89Hmm	\$33.05	6	\$198.35
226		1061107	StorPlus™ Clear Polycarbonate Food Box Capacity: 13L; 304W x 457L x 152Hmm	\$42.35	6	\$254.05

FOOD STORAGE SOLUTIONS						
Catalogue page no.	Image	Item number	Description	List Price EA	Pack size	Pack Price
226		1061207	StorPlus™ Clear Polycarbonate Food Box Capacity: 19L; 304W x 457L x 228Hmm	\$56.70	6	\$339.65
226		1062107	StorPlus™ Clear Polycarbonate Food Box Capacity: 32L; 660W x 457L x 152Hmm	\$79.35	6	\$476.10
226		1062207	StorPlus™ Clear Polycarbonate Food Box Capacity: 47L; 660W x 457L x 228Hmm	\$104.30	4	\$417.15
226		1062307	StorPlus™ Clear Polycarbonate Food Box Capacity: 62L; 660W x 457L x 304Hmm	\$126.45	3	\$379.35
226		1062407	StorPlus™ Clear Polycarbonate Food Box Capacity: 81L; 660W x 457L x 381Hmm	\$149.65	3	\$448.95
226		1061707	StorPlus™ Clear Polycarbonate Lid Fits 304W x 457Lmm Food Boxes of various heights; Lid dimensions: 304W x 457L x 32Hmm	\$20.80	6	\$124.60
226		1062707	StorPlus™ Clear Polycarbonate Lid Fits 660W x 457Lmm Food Boxes of various heights; Lid dimensions: 660W x 457L x 32Hmm	\$41.55	6	\$249.20
226		1062807	StorPlus™ Clear Polycarbonate Colander for Food Box 660W x 457L x 127Hmm	\$60.35	6	\$361.95
226		1062907	StorPlus™ Clear Polycarbonate Drain Grate for 660W x 457Lmm Food Boxes Dimensions: 660W x 457L x 25Hmm	\$33.65	6	\$201.85

WASTE MANAGEMENT

Catalogue page no.	Image	Item number	Description	List Price EA	Pack Size	Pack Price
331		342941REC14	Rectangle Recycle Office Wastebasket Capacity 39 Litre; Colour Blue; Bag hook for liner; Slim design; Polypropylene construction; 384L x 280W x 499Hmm	\$45.25	12	\$542.90
329		34294103	Rectangle Office Wastebasket Capacity 39 Litre; Colour Black; Bag hook for liner; Slim design; Polypropylene construction; 387L x 286W x 495Hmm	\$41.80	12	\$501.15
329		34292803	Rectangle Office Wastebasket Capacity 26 Litre; Colour Black; Bag hook for liner; Slim design; Polypropylene construction; 368L x 267W x 381Hmm	\$22.65	12	\$271.45
329		34291303	Rectangle Office Wastebasket Capacity 10 Litre; Colour Black; Bag hook for liner; Slim design; Polypropylene construction; 292L x 201W x 305Hmm	\$21.50	12	\$257.55
327		34201523	TrimLine™ Rectangle Waste Container Capacity 57L; Colour Grey; Fits narrow spaces; Self-venting for easier bag removal; Handle helper on base for easy lifting; 508L x 267W x 629Hmm	\$102.10	4	\$408.35
327		34202323	TrimLine™ Rectangle Waste Container Capacity 87L; Colour Grey; Fits narrow spaces; Self-venting for easier bag removal; Handle helper on base for easy lifting; 510L x 280W x 762Hmm	\$127.60	4	\$510.40
327		34202303	TrimLine™ Rectangle Waste Container Capacity 87L; Colour Black; Fits narrow spaces; Self-venting for easier bag removal; Handle helper on base for easy lifting; 510L x 280W x 762Hmm	\$127.60	4	\$510.40
327		36921003	TrimLine™ Dolly Colour Black; To suit 34202303 / 34201523; 330W x 560Lmm with 76mm castors	\$176.35	1	\$176.35
327		34202503	TrimLine™ Rectangle Handled Waste Container Lid; Colour Black; 521L x 294W x 76Hmm	\$106.75	4	\$426.90
327		34202403	TrimLine™ Rectangle Swing Top Waste Container Lid; Colour Black; 513L x 294W x 114Hmm	\$92.80	4	\$371.20





WASTE MANAGEMENT

Catalogue page no.	Image	Item number	Description	List Price EA	Pack Size	Pack Price
324		34103203	Bronco™ Black Round Waste Bin; Capacity 121L; Heavy duty construction with double reinforced stress ribs; Drag skids for durability; Bottom dia 457mm x 705Hmm; Top dia 579mm; Top dia with handles 648mm	\$95.15	4	\$380.50
324		34103223	Bronco™ Grey Round Waste Bin; Capacity 121L; Heavy duty construction with double reinforced stress ribs; Drag skids for durability; Bottom dia 457mm x 705Hmm; Top dia 579mm; Top dia with handles 648mm	\$95.15	4	\$380.50
324		34103303	Bronco™ Round Waste Bin Lid - Black; Suits 121L Bronco™ Round Waste Bin; 571mm dia x 54Hmm	\$30.20	4	\$120.65
324		34103323	Bronco™ Round Waste Bin Lid - Grey; Suits 121L Bronco™ Round Waste Bin; 571mm dia x 54Hmm	\$30.20	4	\$120.65
324		34102003	Bronco™ Black Round Bin; Capacity 75L; Heavy duty construction with double reinforced stress ribs; Drag skids for durability; Bottom dia 413mm x 585Hmm; Top dia 508mm; Top dia with handles 585mm	\$69.60	6	\$417.60
324		34102023	Bronco™ Grey Round Bin; Capacity 75L; Heavy duty construction with double reinforced stress ribs; Drag skids for durability; Bottom dia 413mm x 585Hmm; Top dia 508mm; Top dia with handles 585mm	\$69.60	6	\$417.60
324		34102103	Bronco™ Round Waste Bin Lid to Suit 75 Litre Bronco™ Round Waste Bin; Colour Black; Dimensions: 508mm dia x 32Hmm	\$19.75	6	\$118.35
324		34102123	Bronco™ Round Waste Bin Lid to Suit 75 Litre Bronco™ Round Waste Bin; Colour Grey; Dimensions: 508mm dia x 32Hmm	\$19.75	6	\$118.35
325		3691103	Bronco™ Round Waste Container Dolly; Suits Bronco™ Round Waste Bins; Simple twist-to-lock feature attaches dolly to container; Five 76mm castors; 454mm dia x 127Hmm	\$133.40	2	\$266.80

CATERAIDE™ INSULATED CONTAINERS

Catalogue page no.	Image	Item number	Description	Pack size	Each price / Pack price
174		XT500003	Cateraide™ Insulated Beverage Server; Capacity 19L; Colour Black; Stain & scratch resistant polyethylene exterior; Temperature retention for 6-8 Hr; Max temp 82.2°C; Spout clearance 127mm; 430L x 267W x 654Hmm	1	\$498.80
171		IT40003	Cateraide™ IT End Loading Insulated Food Pan Carrier; Colour Black; 676L x 460W x 740Hmm; Temperature retention for 6+ Hr; Capacity: 6 x Full size 65mm pans (12 x half size) OR 4 x Full size 100mm pans (8 x half size) OR 2 x Full size 150mm pans (4 x half size) OR 1 x Full size 200mm pans	1	\$986.00
171		IT41003	Cateraide™ Dolly to Suit IT40003 Pan Carrier; Colour Black; 76mm non-marking wheels; 676L x 473W x 245Hmm	1	\$417.60
176		PC300N03	Cateraide™ Insulated Front Loading Food Pan Carrier Colour Black; 616L x 432W x 641Hmm Temperature retention for 6+ Hr; Nylex Latches; Capacity: 5 x Full size 65mm pans (10 x half size) OR 3 x Full size 100mm pans (8 x half size) OR 2 x Full size 150mm pans (4 x half size) OR 1 x Full size 200mm pan	1	\$870.00
176		PC600N03	Cateraide™ 2-Door Insulated Food Pan Carrier Colour Black; 616L x 432W x 1270Hmm Temperature retention for 6+ Hr; 127mm non-marking castors; Capacity: 10 x Full size 65mm pans (20 x half size) OR 6 x Full size 100mm pans (12 x half size) OR 4 x Full size 150mm pans (8 x half size) OR 1 x Full size 200mm pan	1	\$2088.00
176		PC66014	CaterCooler™ Exclusive CaterCooler; Colour: Blue; Designed to slide into a Cateraide™ Insulated Carriers (PC300N03, PC600N03) Once charged overnight, keeps food cold for up to 8 hrs	1	\$220.40
179		IC225003	Cateraide™ Ice Caddy on Castors; 56kg ice capacity; 2 fixed and 2 swivel castors 1 with brake; Dimensions including handle 711L x 565W x 730Hmm	1	\$1798.00



CATERAIDE™ INSULATED CONTAINERS

Catalogue page no.	Image	Item number	Description	Pack size	Each price / Pack price
179		IC222003	Cateraide™ Ice Caddy on Castors; 90kg ice capacity; 2 fixed and 2 swivel castors 1 with brake; Dimensions including handle 781L x 559W x 927Hmm	1	\$2186.60
171		IT16003	Cateraide™ IT Top Loading Insulated Food Pan Carrier; Colour Black; 676L x 460W x 740Hmm; Temperature retention for up to 6 Hr; Capacity: 1 x Full size pan OR 2 x half size pans OR 3 x third size pans	1	\$788.80
178		XDL3000H03	Cateraide™ Dolly with Handle; Colour Black; 100mm heavy duty non-marking castors; Holds up to 2 XT3000R Pan Carriers when stacked; Holds all Cateraide™ Top Loader Pan Carriers except PC180N and PC188N. Dimensions 730L x 570W x 994Hmm	1	\$661.20
175		LD250N03	Cateraide™ LD Insulated Beverage Server; Colour Black; Capacity 9.5L; Keeps beverages hot or cold for up to 4-6 hours; Nylex II Latches; Dimensions 419L x 229 x 457Hmm	1	\$423.40

MATERIAL HANDLING

Catalogue page no.	Image	Item number	Description	Pack size	Each price / Pack price
318		UC452523	Large Bin Top Utility Cart; Colour Grey; Durable, chemical resistant polypropylene construction; Dent, rust & chip resistant. Wt capacity per shelf 113kg; 1143L x 685W x 838Hmm; 76mm high "lip" prevents objects from falling during transit.	1	\$620.60
318		UC194023	Flat Shelf Utility Cart; Colour Grey; Durable, chemical resistant polypropylene construction; Dent, rust & chip resistant. Wt capacity per shelf 113kg; 1026L x 483W x 830Hmm	1	\$615.80
316		CC224303	Bussing Cart; Colour Black; Wt capacity 136kg; 1067L x 584W x 953Hmm	1	\$800.40
315		SBC203103	Large Fold 'N Go® Cart; Colour Black; Unfolded dimensions 520W x 1016L x 1099Hmm; Collapses to 267W x 1016Lmm; Easy to store in limited space; Non-marking castors; 20mm solid aluminium legs; Wt capacity per shelf 53kg;	1	\$1566.00
315		SBC152103	Small Fold 'N Go® Cart; Colour Black; Unfolded dimensions 406W x 749L x 908Hmm; Collapses to 229W x 749Lmm; Easy to store in limited space; Non-marking castors; 20mm solid aluminium legs; Wt capacity per shelf 53kg;	1	\$1275.85
317		SBC23003	Service Cart on Castors; Colour Black; 854L x 515W x 870Hmm; Wt capacity per shelf 75kg; One-piece design; Polyethylene exterior and polyurethane foam core for added strength; 127mm non-marking castors, 2 fixed and 2 swivel, 1 with brake.	1	\$1415.20
317		SBC11TC03	Rubbish Container to Suit SBC23003; Colour Black; 409L x 238W x 555Hmm	1	\$208.80
317		SBC11SH03	Silverware Holder to Suit SBC23003; Colour Black; 390L x 157W x 274Hmm	1	\$185.60







MATERIAL HANDLING

Catalogue page no.	Image	Item number	Description	Pack size	Each price / Pack price
333		TTLD58003	Black Light Duty Utility Tilt Truck; Capacity 204kg; Constructed from 70% post-consumer recycled material; Powder coated steel wheel frame; 250mm rear wheels and 100mm front castors; Dimensions 1370L x 660W x 965Hmm	1	\$1728.40
333		TTS58003	Black Standard Duty Utility Tilt Truck; Capacity 385kg; Constructed from 70% post-consumer recycled material; Powder coated steel wheel frame; 250mm rear wheels and 100mm front castors; Dimensions 1727L x 825W x 1086Hmm	1	\$1856.00
319		ADS403	Optimizer™ Adjustable Small Dish Dolly; 4 dividers and 4 swivel wheels; Dimensions 737W x 737L x 806Hmm	1	\$1972.00



WAREWASHING

Catalogue page no.	Image	Item number	Description	List Price EA	Pack Size	Pack Price
246		RP14	OptiClean™ All-Purpose Peg Dish Rack; Colour Blue; Open design for even and thorough washing, drying & draining; 500L x 500W x 102Hmm; Peg height 63mm; Space between pegs 45mm	\$55.70	6	\$334.10
246		RTP14	OptiClean™ All-Purpose Peg Dish Rack Colour Blue; Open design for even and thorough washing, drying & draining; 500L x 500W x 102Hmm; Peg height 76mm; Space between pegs 45mm	\$56.85	6	\$341.05
246		ROP14	OptiClean™ Open Side All-Purpose Peg Dish Rack Colour Blue; Open design for even and thorough washing, drying & draining; 500L x 500W x 102Hmm; Peg height 76mm; Space between pegs 45mm	\$55.70	6	\$334.10
246		RB14	OptiClean™ Open Bowl Rack Colour Blue; Open design for even and thorough washing, drying & draining; 500L x 500W x 102Hmm;	\$34.80	6	\$208.80
246		RF14	OptiClean™ Flatware Rack; Colour Blue; Open design for even and thorough washing, drying & draining; 500L x 500W x 102Hmm; 464mm compartment Tight enough to keep small items contained	\$35.95	6	\$215.80
247		RFP14	OptiClean™ Food Pan or Insulated-Meal-Delivery-Tray Rack; Colour Blue; Open design for even and thorough washing, drying & draining; 500L x 500W x 102Hmm;	\$156.60	3	\$469.80
247		RC20-114	OptiClean™ 20 Compartment Divided Rack with one open extender; Colour Blue; 500L x 500W x 140Hmm with extender; Compartment 120mm depth x 110L x 87Wmm Open Tilted Design – Compartments hold cups in a tilted position, promoting even and thorough washing, drying and draining	\$49.90	4	\$199.55
244		RG25-114	OptiClean™ 25 Compartment Divided Rack with one 25 compartment divided extender; Colour Blue; 500L x 500W x 140Hmm with extender; Compartment 120mm depth x 90L x 90Wmm	\$62.65	4	\$250.60
245		RG36-114	OptiClean™ 36 Compartment Divided Rack with one 36 compartment divided extender; Colour Blue; 500L x 500W x 140Hmm with extender; Compartment 120mm depth x 74L x 74Wmm	\$62.65	4	\$250.60



WAREWASHING

Catalogue page no.	Image	Item number	Description	List Price EA	Pack Size	Pack Price
245		RG49-114	OptiClean™ 49 Compartment Divided Rack with one 49 compartment divided extender; Colour Blue; 500L x 500W x 140Hmm with extender; Compartment 120mm depth x 60L x 60Wmm	\$65.00	4	\$259.85
248		C32P214	Perma-Sil™ 8-Compartment Dishwash Cutlery Storage Basket; Colour Blue; Open weave basket design for optimum air and water flow for efficient washing & drying; 433L x 197W x 175Hmm; Compartment 90L x 90Wmm	\$60.35	6	\$365.40
244		RE2514	OptiClean™ 25-Compartment Divided Rack Extender; Colour Blue; 500L x 500W x 45Hmm; Compartment 90L x 90Wmm	\$20.90	6	\$125.30
245		RE3614	OptiClean™ 36-Compartment Divided Rack Extender; Colour Blue; 500L x 500W x 45Hmm; Compartment 74L x 74Wmm	\$20.90	6	\$125.30
249		C223614	E-Z Glide™ Warewashing Rack Dolly Without Handle; Wt Capacity 150 kg; Holds any std 500mm racks; Colour Blue; 572L x 572W x 203Hmm	\$324.80	1	\$324.80
249		C223703	E-Z Glide™ Handle for C223614; Colour Black; Material Steel	\$359.60	1	\$359.60
249		RDC07	OptiClean™ Dust Cover for ware washing racks; Colour – Clear; 533L x 533W x 914Hmm	\$156.60	3	\$469.80

JANITORIAL

Catalogue page no.	Image	Item number	Description	List Price EA	Pack Size	Pack Price
285		36141503	Duo-Pan™ Lobby Pan with Broom; Colour Black; Pivoting design for clean transportation of contents without messy spills; 292L x 300W x 914Hmm	\$55.70	1	\$55.70
285		36141203	Duo-Pan™ Broom Handle Clip for 36141503; Colour Black;	\$3.15	12	\$37.60
286		36141003	Duo-Pan™ Upright Plastic Lobby Pan with Metal Handle; Colour Black; Overall length 914mm	\$37.15	6	\$222.75
285		36141603	DuraPan™ Upright Dust Pan & Broom Colour Black; Overall length 914mm	\$63.80	4	\$255.20
278		3686100	Duo-Sweep® Lobby Angle Broom; Flare Polypropylene Bristles; Bristle length 102mm to 114mm; Overall length 914mm	\$25.55	12	\$306.25
307		3694104	Caution Cone; Colour Yellow; Portable and lightweight; Height 915mm; Base width 317mm	\$103.25	3	\$309.75
307		3694204	Pop-Up Caution Cone Colour Yellow with grey cone casing; Portable and lightweight; Height 510mm;	\$71.95	12	\$863.05
270		3623900	Sparta® Hand & Nail Brush; Colour White; Polypropylene Bristles; Bristle length 11mm to 14mm; Block size 38W x 89Lmm	\$3.50	24	\$83.55
287		4042302	Sparta® Hi-Lo™ Floor Scrub Brush; Colour White; Self-locking flex tip for greater flexibility; Bristle length 38mm to 44mm; Block size 254L x 114W x 89Hmm	\$32.50	12	\$389.80

JANITORIAL

Catalogue page no.	Image	Item number	Description	List Price EA	Pack Size	Pack Price
295		4526700	Metal Tip Threaded Wooden Handle; Length 1524mm; Dia 24mm	\$13.00	12	\$159.95
293		4022502	Sparta® Fiberglass Handle; Self-Locking Flex-Tip; Length 1524mm; Dia 25mm	\$37.15	12	\$445.45