



Project _____

Item # _____

Quantity _____

R-290 Cold Shelves Undermount

Models:

CSUP-24-F, -24-I, -24-S, -36-F, -36-I, -36-S, -48-F, -48-I, -48-S

Hatco's R-290 Cold Shelves Undermount are designed to keep your products in the perfect chill zone.

Undermount shelves have the amazing benefit of being able to be installed under the countertop top of your choice!

Standard features

- Mounts directly to underside of appropriate countertop material
- Approved materials include granite and quartz up to 1³/₁₆" (30 mm), Swanstone® and certain stainless steel or aluminum surfaces approved by Hatco. Please contact the factory for applications with other material
- CSUP condenser utilizes environmentally friendly R-290 refrigerant
- All units have an Electronic Temperature Control Box with a 4' (1219 mm) lead wire (Standard)
- All models feature an anodized aluminum surface

Make structural modifications or add bracing underneath the countertop to ensure countertop will support the weight of the unit and its contents.

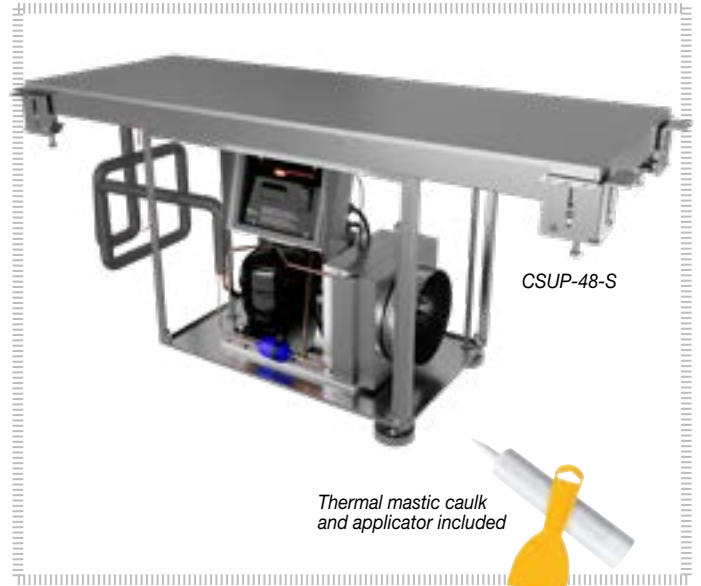



R-290 Cold Shelves Undermount

Models: CSUP-24-F, -24-I, -24-S, -36-F, -36-I, -36-S, -48-F, -48-I, -48-S

CSUP

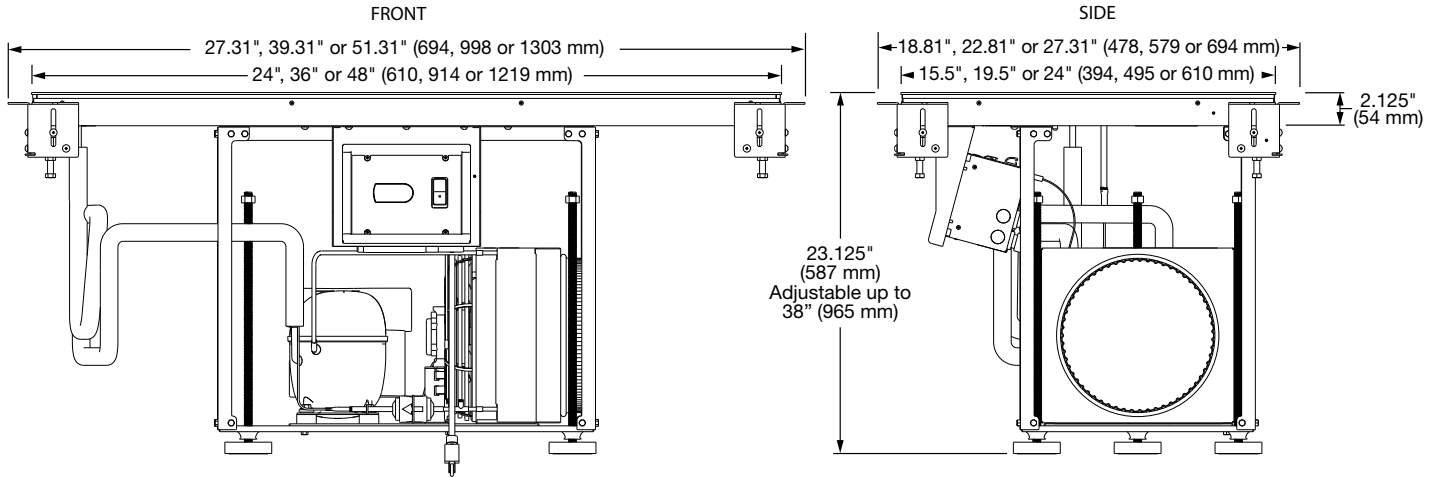

SPECIAL UNDERMOUNT CUTOUT DIMENSIONS

[See Installation and Operating Manual for more information](#)

Model	Countertop Cut-Out 3/8" Radii	Countertop Cut-Out 3/8" Radii (mm)
CSUP-24-F	15.875" x 24.375"	403 x 619 mm
CSUP-24-I	19.875" x 24.375"	505 x 619 mm
CSUP-24-S	24.375" x 24.375"	619 x 619 mm
CSUP-36-F	15.875" x 36.375"	403 x 924 mm
CSUP-36-I	19.875" x 36.375"	505 x 924 mm
CSUP-36-S	24.375" x 36.375"	619 x 924 mm
CSUP-48-F	15.875" x 48.375"	403 x 1229 mm
CSUP-48-I	19.875" x 48.375"	505 x 1229 mm
CSUP-48-S	24.375" x 48.375"	619 x 1229 mm

Note: Special undermount cutout table is only used if customer is mounting to additional construction features below countertop such as plywood. These cutout dimensions provide clearance through which the CSUP can be placed.



R-290 Cold Shelves Undermount

Models: CSUP-24-F, -24-I, -24-S, -36-F, -36-I, -36-S, -48-F, -48-I, -48-S

SPECIFICATIONS

R-290 Cold Shelves Undermount

The shaded areas contain electrical information for International models

Model	Overall Dimensions [‡] W x D x H	Usable Shelf Space W x D	Compressor Size HP	Voltage*	Watts	Amps	Hz	Plug	Total Heat of Rejection (BTU/Hr)	Approx. Ship Weight	
CSUP-24-F	27.31" x 18.81" x 23.125" (694 x 478 x 587 mm)	24" x 15.5" (610 x 394 mm)	1/3	1/5	120	345	5.2	60	NEMA 5-15P	1852	118 lbs. (54 kg)
				50	220	333	3.0	CEE 7-7 Schuko, BS-1363, AS3112	2026		
					230	364	3.2				
					240	396	3.3				
				60	220	333	3.0	BS-1363	2026		
					230	364	3.2				
240	396	3.3									
CSUP-24-I	27.31" x 22.81" x 23.125" (694 x 579 x 587 mm)	24" x 19.5" (610 x 495 mm)	1/3	1/5	120	345	5.2	60	NEMA 5-15P	1992	115 lbs. (52 kg)
				50	220	333	3.0	CEE 7-7 Schuko, BS-1363, AS3112	2166		
					230	364	3.2				
					240	396	3.3				
				60	220	333	3.0	BS-1363	2166		
					230	364	3.2				
240	396	3.3									
CSUP-24-S	27.31" x 27.31" x 23.125" (694 x 694 x 587 mm)	24" x 24" (610 x 610 mm)	1/3	1/5	120	345	5.2	60	NEMA 5-15P	2150	130 lbs. (59 kg)
				50	220	333	3.0	CEE 7-7 Schuko, BS-1363, AS3112	2324		
					230	364	3.2				
					240	396	3.3				
				60	220	333	3.0	BS-1363	2324		
					230	364	3.2				
240	396	3.3									
CSUP-36-F	39.31" x 18.81" x 23.125" (998 x 478 x 587 mm)	36" x 15.5" (914 x 394 mm)	1/3	1/5	120	345	5.2	60	NEMA 5-15P	2123	143 lbs. (65 kg)
				50	220	333	3.0	CEE 7-7 Schuko, BS-1363, AS3112	2297		
					230	364	3.2				
					240	396	3.3				
				60	220	333	3.0	BS-1363	2297		
					230	364	3.2				
240	396	3.3									
CSUP-36-I	39.31" x 22.81" x 23.125" (998 x 579 x 587 mm)	36" x 19.5" (914 x 495 mm)	1/3	1/3	120	440	6.5	60	NEMA 5-15P	2609	140 lbs. (64 kg)
				50	220	333	3.0	CEE 7-7 Schuko, BS-1363, AS3112	2459		
					230	364	3.2				
					240	396	3.3				
				60	220	333	3.0	BS-1363	2459		
					230	364	3.2				
240	396	3.3									
CSUP-36-S	39.31" x 27.31" x 23.125" (998 x 694 x 587 mm)	36" x 24" (914 x 610 mm)	1/3	1/3	120	440	6.5	60	NEMA 5-15P	2821	144 lbs. (66 kg)
				50	220	333	3.0	CEE 7-7 Schuko, BS-1363, AS3112	2671		
					230	364	3.2				
					240	396	3.3				
				60	220	333	3.0	BS-1363	2671		
					230	364	3.2				
240	396	3.3									
CSUP-48-F	51.31" x 18.81" x 23.125" (1303 x 478 x 587 mm)	48" x 15.5" (1219 x 394 mm)	1/3	1/3	120	440	6.5	60	NEMA 5-15P	2664	141 lbs. (64 kg)
				50	220	333	3.0	CEE 7-7 Schuko, BS-1363, AS3112	2514		
					230	364	3.2				
					240	396	3.3				
				60	220	333	3.0	BS-1363	2514		
					230	364	3.2				
240	396	3.3									
CSUP-48-I	51.31" x 22.81" x 23.125" (1303 x 579 x 587 mm)	48" x 19.5" (1219 x 495 mm)	1/3	1/3	120	440	6.5	60	NEMA 5-15P	2915	154 lbs. (70 kg)
				50	220	333	3.0	CEE 7-7 Schuko, BS-1363, AS3112	2765		
					230	364	3.2				
					240	396	3.3				
				60	220	333	3.0	BS-1363	2765		
					230	364	3.2				
240	396	3.3									
CSUP-48-S	51.31" x 27.31" x 23.125" (1303 x 694 x 587 mm)	48" x 24" (1219 x 610 mm)	1/2	1/2	120	560	9.3	60	NEMA 5-15P	4318	176 lbs. (80 kg)
				50	220	454	4.1	CEE 7-7 Schuko, BS-1363, AS3112	4250		
					230	496	4.3				
					240	540	4.5				
				60	220	484	4.4	BS-1363	4373		
					230	529	4.6				
240	576	4.8									



R-290 Cold Shelves Undermount

Models: CSUP-24-F, -24-I, -24-S, -36-F, -36-I, -36-S, -48-F, -48-I, -48-S

FACTORY FILL RATES for R-290 REFRIGERANT

Model	Fill Weight
CSUP-24-F	3.5 oz. (0.099 kg)
CSUP-24-I	3.6 oz. (0.102 kg)
CSUP-24-S	3.7 oz. (0.105 kg)
CSUP-36-F	3.7 oz. (0.105 kg)
CSUP-36-I	3.8 oz. (0.108 kg)
CSUP-36-S	3.9 oz. (0.111 kg)
CSUP-48-F	3.8 oz. (0.108 kg)
CSUP-48-I	4.0 oz. (0.113 kg)
CSUP-48-S	4.5 oz. (0.128 kg)

R-290 REFRIGERANT OPERATING SPECIFICATIONS IN 75°F (24°C) AMBIENT

 [\(Refer to the Installation section in the Installation and Operating Manual on the Hatco website\)](#)

- Suction Pressure: 13-23 PSIG (0.9-1.6 Bar)
- Discharge Pressure: 140-180 PSIG (9.7-12.4 Bar)
- Superheat: 4-10° F (2.2 to 5.6°C)
- Subcooling: 5-10° F (2.8 to 5.6°C)

MOUNTING BOLT AND SUBSTRATE CUTOUT DIMENSIONS

 [\(Refer to the Installation section in the Installation and Operating Manual on the Hatco website\)](#)

PLUG CONFIGURATION

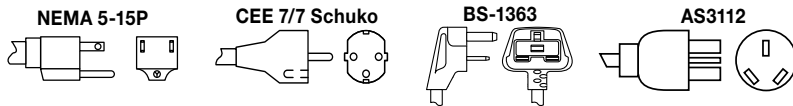

PRODUCT SPECS

R-290 Cold Shelves Undermount

The R-290 Cold Shelves Undermount shall be model ... as manufactured by the Hatco Corporation, Milwaukee, WI 53234 U.S.A.

The Cold Shelves Undermount shall be rated at ... watts, ... volts, and ... inches (millimeters) in overall width.