



Project _____

Item # _____

Quantity _____



Heated Drawer Warmer with Top Control

Models: HDWTC-1, -2, -3

Hatco Drawer Warmers ensure optimal holding of protein products at safe temperatures, while minimizing moisture loss and texture change. Our unique blanket element design promotes uniform temperatures throughout the cavity. Each drawer features adjustable sliding vents. Touchscreen Controller controls temperature and time for each drawer individually.

Standard features

- Top-of-the-unit Touchscreen Controller is positioned at an angle for greater visibility
- Controller allows individual temperature control and hold timer per drawer with both visual and audio alerts
- Robust stainless steel construction inside and out.
- Constructed of heavy duty, 12 gauge drawer frame and slides with nylon rollers
- Easy-to-clean seamless, interior core
- Snap out side panels make this unit easy to clean and service
- Each drawer has adjustable vents for varying moisture levels in individual drawers
- Drawer frame can accommodate varying pan configurations, including 1/1 GN, 1/3 GN, 1/3 GN up to 6" (152 mm) deep, with or without lids.
- Pans lift straight up; eliminating the need to tilt pan for removal
- USB port for easy software updates
- Unit comes standard with adjustable plastic legs 4" - 5.375" (102-137 mm)
- Includes 6' (1829 mm) cord located on the upper back corner
- CE versions come with anti-tip bracket and hardware



HDWTC-2
shown with Accessory 2" (64 mm) casters,
4" (102 mm) legs are standard

Options (available at time of purchase only)

Pan options

- 6" (152 mm) deep pan - 20" x 12" x 6" (508 x 305 x 152 mm)
- Oversize pan, 20" x 15" x 5" (508 x 381 x 127 mm)
- No pan

Accessories

- Custom trivet raises food product .5" (13 mm) off bottom of full size pan 17.5" x 9.5" x .5" (445 x 242 x 13 mm)

Legs and Casters

- 6" (152 mm) Stainless Steel adjustable Legs adds 6" - 7.5" (152-191 mm) to height
- 6" (152 mm) plastic legs adds 6" (152 mm) to height
- 2" (51 mm) diameter Locking Casters - all swivel, 2 lock - adds 2.5" (64 mm) to height
- 3" (76 mm) diameter locking casters - adds 4.25" (108 mm) to height
- 4" (102 mm) diameter locking casters - adds 5.25" (133 mm) to height
- 5" (127 mm) diameter locking casters - adds 6.25" (159 mm) to height

- Stainless Steel Food Pans



Heated Drawer Warmer with Top Control

Models: HDWTC-1, -2, -3

HDWTC

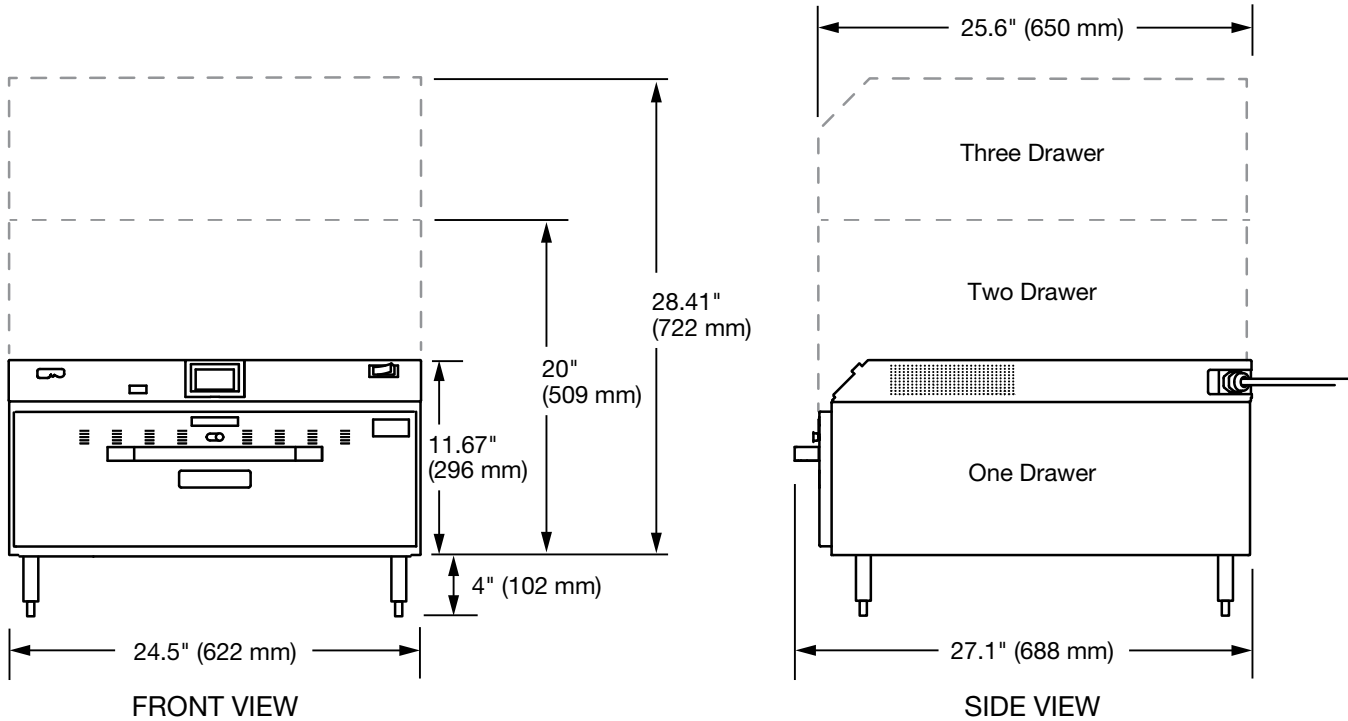

SPECIFICATIONS Heated Drawer Warmers with Top Control

The shaded areas contain electrical information for International models

Models	Dimensions ‡ (W x D x H)	Volts	Watts	Amps	Plugs	Approx. Ship Weight
HDWTC-1	24.5" x 25.6" x 15.67" (622 x 650 x 398 mm)	120	353	2.9	NEMA 5-15P	120 lbs (55 kg)
		220/230/240	323/353/384	1.5 / 1.5 / 1.6	BS-1363, CEE 7/7	
HDWTC-2	24.5" x 25.6" x 24" (622 x 650 x 611 mm)	120	704	5.9	NEMA 5-15P	178 lbs (81 kg)
		220/230/240	645/704/766	2.9 / 3.1 / 3.2	BS-1363, CEE 7/7	
HDWTC-3	24.5" x 25.6" x 32.41" (622 x 650 x 824 mm)	120	1055	8.8	NEMA 5-15P	217 lbs (99 kg)
		220/230/240	966/1055/1048	4.4 / 4.6 / 4.8	BS-1363, CEE 7/7	

‡ Height includes standard 4" (102 mm) plastic legs, add 1½" (38 mm) to depth for door handles.

CORD LOCATION

Top, back-left side, recessed to protect plug.

PLUG CONFIGURATIONS

