

TOP VIEW

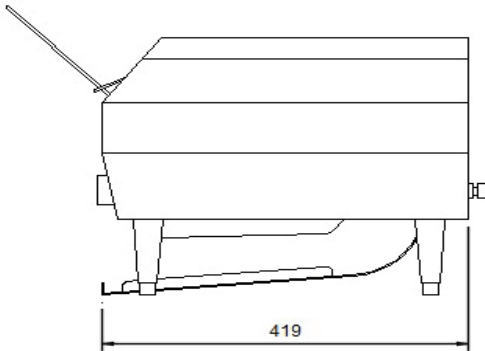

FRONT VIEW  
NTS

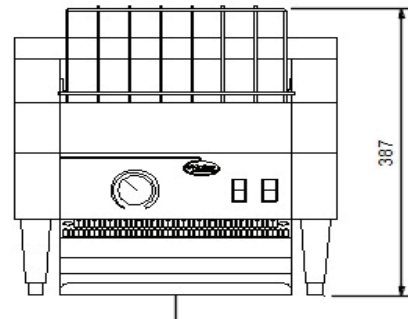

SIDE VIEW

The **Hatco Toast-Max** entry-level conveyor toaster offers the flexibility and performance to perfectly toast bread and buns fast. Utilising conveyor speed, not temperature, to determine toasting colour, this allows for instant adjustment of toasting time to maintain quality.

**STANDARD FEATURES**

- 4 position toast selector switch:off / toast / buns / standby mode
- 89mm clearance to accommodate high profile bread products.
- Easy-to-load rack with front or rear discharging.
- V-shaped reflectors help capture and redirect heat.
- Long lasting serpentine metal sheathed heating elements.
- 102mm adjustable legs.
- Pilot light signals unit is in operation.
- Discharge & crumb trays are removable.

**SPECIFICATION**

Dimensions	368W x 419D x 387Hmm
Weight	19Kgs
Output Power	1.9 Kw
Power Source	8 amps. Supplied with 10amp plug.