



TURBO LIQUIDIZERS SERIES

GIGAMIX XS BLENDER

Ref : TB120 / Three-phased



COMPACT SIZE,
IDEAL FOR HIGH
VOLUME PREPARATIONS !



DESCRIPTION

- Enhanced maneuverability thanks to its 3 wheels of which 1 steering wheel.
- Compact size, minimum space requirement. Easy storage thanks to its size.
- Retractable equipment.
- All stainless steel for easy cleaning and a perfect hygiene.
- Blocking system.
- Accessory storage box.
- Works directly in pots.
- Offers long service lifetime for intensive use.
- Long operating life.



BLOCKING SYSTEM

ACCESSORIES

- DYNA PUMP :
Ref. TB030
- GIGAMIX GUN :
Ref. TB040



USE

Blender : Grind, crush, mix, emulsify, homogenize and smooth your preparations in a record time !

The blender homogenizer tool allows to obtain a smooth, creamy and a perfect texture, that doesn't require sieving.

Dynapompe : With its innovative process, the DYNAMIC Pump perfectly adapts to the GIGAMIX blender foot to quickly and effortlessly transfer the mixed preparation into the packaging area.

Capacity : 40 to 150 L.

The GIGAMIX XS, GIGAMIX's «little sister» is designed for medium preparations.

This turbo liquidizer is specially designed for intensive use in production kitchens.



MAINTENANCE

In a few seconds and without dismantling anything, the stainless steel tube and bell can be washed with clear water only. The single-phased electric connection must be done by a professional.

It's preferable to regularly check the wear on bearings, seals and O-ring.



TECHNICAL DATA

OUTPUT	1.5 KW
SPEED	2800 R.P.M.
VOLTAGE	400 V three-phased with neutral, 50 Hz*
MINIMUM HEIGHT - under bell -	190 mm
MAXIMUM HEIGHT - under bell -	850 mm
DIAMETER BELL	98 mm
ACTUAL WEIGHT	71 kg

*Other voltages on request.

ELECTRIC REQUIREMENTS

This appliance can have a three-phased power supply with neutral and is earthed. The installation must be protected by a ground fault circuit breaker 4x16 A 30mA for a three-phase power supply.

Check that the mains voltage and the voltage indicated on the appliance's identification plate are the same.

ACCESSORIES



**Dynapump
Gigamix**

Adaptable on
Blender tool only.

Tube's length
provided with
the pump : 2.5m



**Gigamix
Gun**

Optional accessory
for Dynapump.

Ref.: TB030

Ref.: TB040

VOLUME

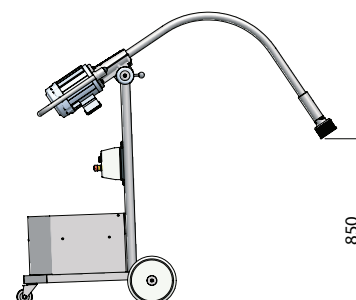
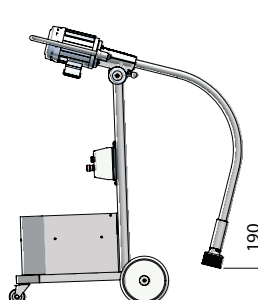
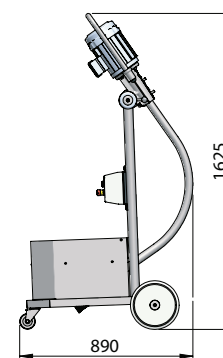
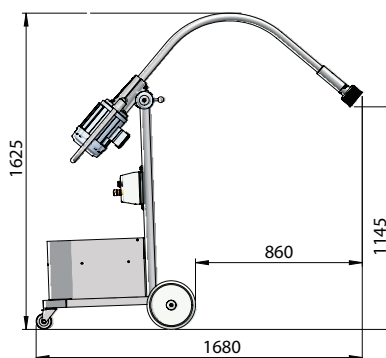
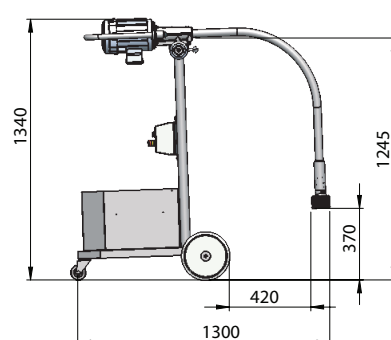
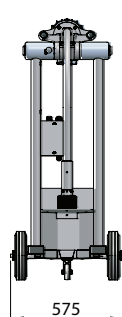

TECHNICAL SHEET

PART LIST	CODE
Ø250MM WHEEL	0669XS
SCREW M10X30	0794
80X40 CAP	07998
WELDED CHASSIS	089950XS
WELDED BASKET	089951XS
RING 50 X 12 X 5 STAINLESS STEEL GIGAMIX	089953.V
430V THREE-PHASED MOTOR-BLOCK	9320
230V ONE-PHASED MOTOR-BLOCK	9320.1
420V THREE-PHASED COMPLETE CHASSIS	9321
230V ONE-PHASED COMPLETE CHASSIS	9321.1
KIT FOR BIG WHEEL	932101
KIT FOR WHEEL WITH BRAKE	932102
420V THREE-PHASED CONTROL BOX	932104
230V ONE-PHASED CONTROL BOX	932104.1
SCREW SET FOR ASSEMBLY	9375
BLENDER GIGAMIX	TB004

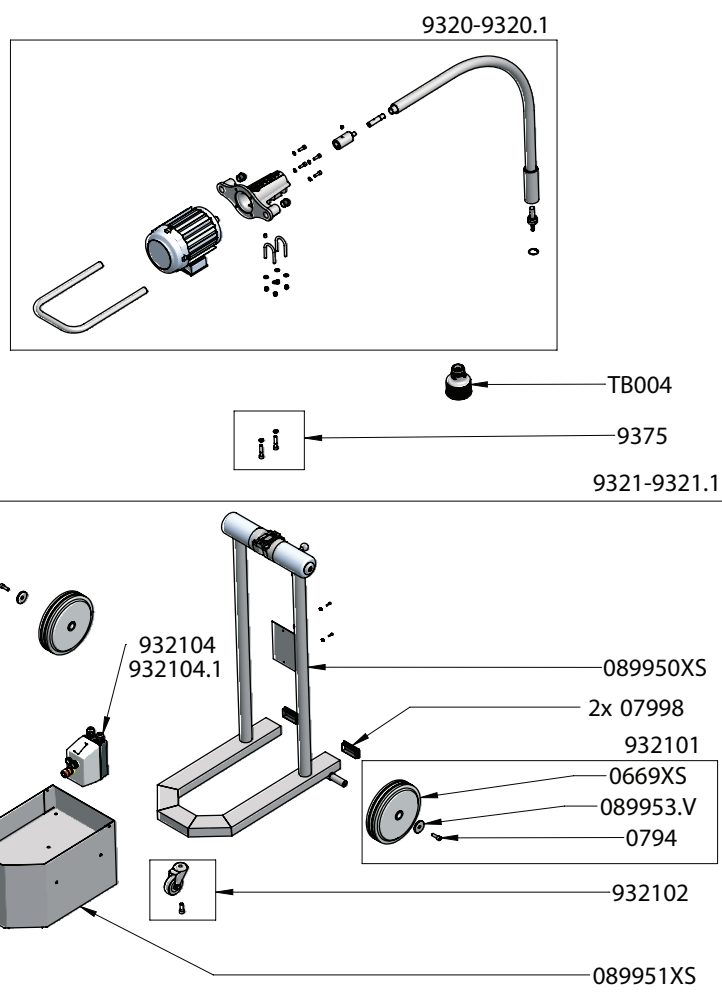

TECHNICAL SHEET

DYNAPUMP - Ref TB030

Parts list Code

Right half clamp	08999930
Left half clamp	08999931
3/4 Stainless male cap	08999932
3/4 Stainless female reducer	08999933
Pump hinge	08999935
3/4 Male fitting	08999936
Hose nipple camlock fittings DN19	08999937
3/4 Hose nipple threaded connection	08999939
25-35 Hose clamp	08999940
Pump distribution gun	08999941
Pump locker + washer + butterfly nut	9347
Gigamix Gun	TB040
Hose pipe (2,5 cm)	TB045
Hose pipe with cam axle	TB046

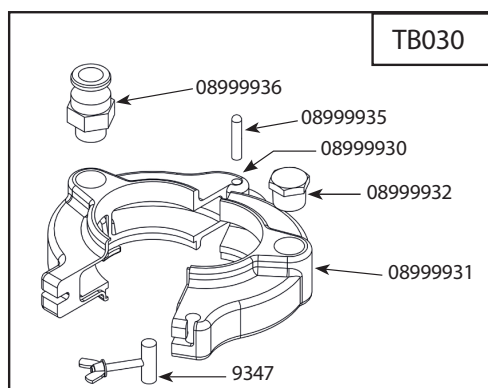
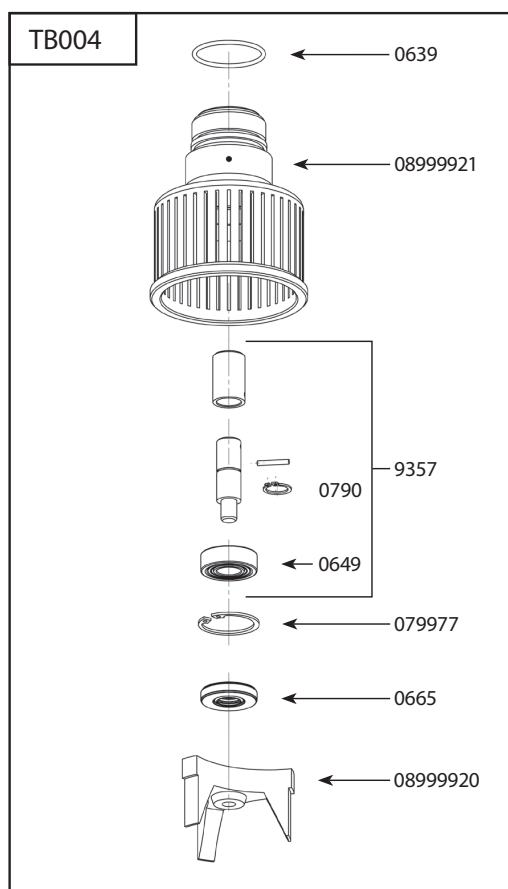
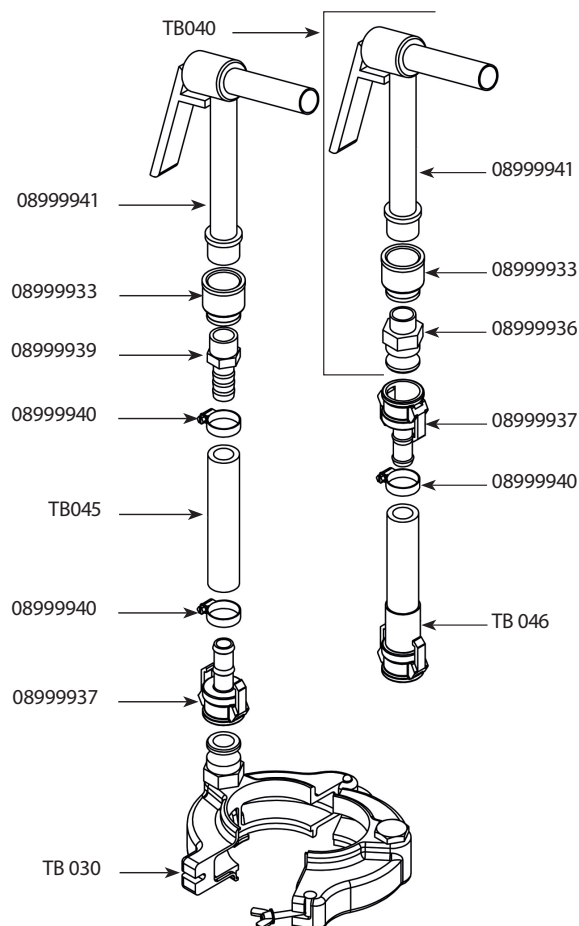

Parts list Code

BLENDER FOOT GIGAMIX TB004

Toric joint	0639
Ball bearing	0649
Waterproof seal	0665
Elastic ring Ø15	0790
Elastic ring Ø35	079977
Hammer	08999920
BLENDER GIGAMIX bell	08999921
Lower shaft + bearing + coupling + clips	9357
Waterproof set (seal+bear+screw+clips)	9348